

# HYDRAULIC MOTORS MV

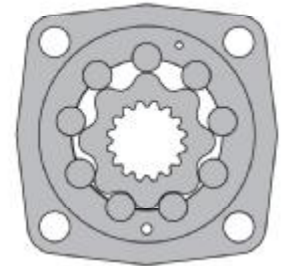

## APPLICATION

- » Conveyors
- » Metal working machines
- » Agricultural machines
- » Road building machines
- » Mining machinery
- » Food industries
- » Special vehicles
- » Plastic and rubber machinery etc.

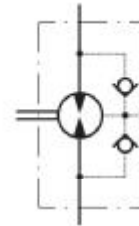

## CONTENTS

Specification data .....	39
Function diagrams .....	41+43
Permissible shaft loads .....	43
Dimensions and mounting .....	44+46
Dimensions and mounting - MVS .....	47
Dimensions and mounting - MVV .....	48
Internal Spline data .....	49
Tacho connection.....	49
Shaft extensions .....	50
Order code .....	50

## OPTIONS

- » Model - Disc valve, roll-gerotor
- » Flange and wheel mount
- » Short motor
- » Tacho connection
- » Speed sensing
- » Side ports
- » Shafts - straight, splined and tapered
- » BSPP ports
- » Other special features

## GENERAL

<b>Max. Displacement,</b> cm <sup>3</sup> /rev [in <sup>3</sup> /rev]	801.8 [48.91]
<b>Max. Speed,</b> [RPM]	630
<b>Max. Torque,</b> daNm [lb-in]	cont.: 188 [16650] int.: 211 [18650]
<b>Max. Output,</b> kW [HP]	64 [85,8]
<b>Max. Pressure Drop,</b> bar [PSI]	cont.: 200 [2900] int.: 240 [3480]
<b>Max. Oil Flow,</b> lpm [GPM]	240 [63.4]
<b>Min. Speed,</b> [RPM]	5
<b>Permissible Shaft Loads</b> daN [lbs]	P <sub>r</sub> =1500 [3300]
<b>Pressure fluid</b>	Mineral based- HLP(DIN 51524) or HM(ISO 6743/4)
<b>Temperature range,</b> °C [°F]	-40+140 [-40+284]
<b>Optimal Viscosity range,</b> mm <sup>2</sup> /s [SUS]	20+75 [98+347]
<b>Filtration</b>	ISO code 20/16 (Min. recommended fluid filtration of 25 microns)

Oil flow in drain line

Pressure drop bar [PSI]	Viscosity mm <sup>2</sup> /s [SUS]	Oil flow in drain line lpm [GPM]
140 [2030]	20 [98]	3 [.793]
	35 [164]	2 [.528]
210 [3045]	20 [98]	6 [1.585]
	35 [164]	4 [1.057]

Pressure Losses

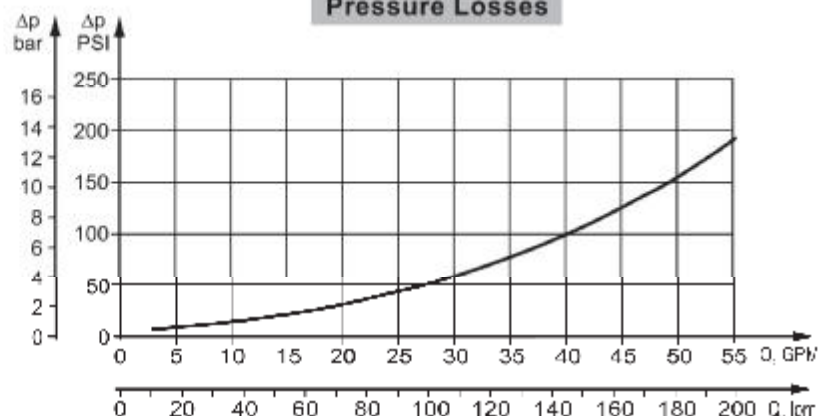



**SPECIFICATION DATA**

Type		MV 315	MV 400	MV 500	MV 630	MV 800
Displacement, cm <sup>3</sup> /rev [In <sup>3</sup> /rev]		314,5 [19.18]	400,9 [24.45]	499,6 [30.48]	629,1 [38.38]	801,8 [48.91]
Max. Speed, [RPM]	Cont.	510	500	400	320	250
	Int.*	630	600	480	380	300
Max. Torque daNm [lb-in]	Cont.	92 [8150]	118 [10450]	146 [12950]	166 [14700]	188 [16650]
	Int.*	111 [9800]	141 [12500]	176 [15550]	194 [17150]	211 [18650]
	Peak**	129 [11400]	164 [14500]	205 [18150]	221 [19550]	247 [21850]
Max. Output kW [HP]	Cont.	42,5 [57]	53,5 [71.7]	53,5 [71.7]	48 [64.4]	42,5 [57]
	Int.*	51 [68.4]	64 [85.8]	64 [85.8]	56 [75]	48 [64.4]
Max. Pressure Drop bar [PSI]	Cont.	200 [2900]	200 [2900]	200 [2900]	180 [2610]	160 [2320]
	Int.*	240 [3480]	240 [3480]	240 [3480]	210 [3050]	180 [2610]
	Peak**	280 [4060]	280 [4060]	280 [4060]	240 [3480]	210 [3050]
Max. Oil Flow lpm [GPM]	Cont.	160 [42.3]	200 [52.8]	200 [52.8]	200 [52.8]	200 [52.8]
	Int.*	200 [52.8]	240 [63.4]	240 [63.4]	240 [63.4]	240 [63.4]
Max. Inlet Pressure bar [PSI]	Cont.	210 [3050]	210 [3050]	210 [3050]	210 [3050]	210 [3050]
	Int.*	250 [3620]	250 [3620]	250 [3620]	250 [3620]	250 [3620]
	Peak**	300 [4350]	300 [4350]	300 [4350]	300 [4350]	300 [4350]
Max. Return Pressure with Drain Line bar [PSI]	Cont.	140 [2040]	140 [2040]	140 [2040]	140 [2040]	140 [2040]
	Int.*	175 [2540]	175 [2540]	175 [2540]	175 [2540]	175 [2540]
	Peak**	210 [3050]	210 [3050]	210 [3050]	210 [3050]	210 [3050]
Max. Starting Pressure with Unloaded Shaft, bar [PSI]		8 [120]	8 [120]	8 [120]	8 [120]	8 [120]
Min. Starting Torque daNm [lb-In]	At max. press. drop Cont.	71 [6300]	91 [8100]	113 [10000]	133 [11800]	151 [13400]
	At max. press. drop Int.*	85 [7500]	109 [9600]	136 [12000]	155 [13700]	170 [15000]
Min. Speed***, [RPM]		10	9	8	6	5
Weight, kg [lb]	MV	31,8 [70.1]	32,6 [71.9]	33,5 [73.8]	34,9 [76.9]	36,5 [80.5]
	MVW	32,4 [71.4]	33,2 [73.2]	34,1 [75.2]	35,5 [78.3]	37,1 [81.8]
	MVS	22,7 [50]	23,5 [51.8]	24,4 [53.8]	25,6 [56.4]	27,7 [61.1]

\* Intermittent operation: the permissible values may occur for max. 10% of every minute.

\*\* Peak load: the permissible values may occur for max. 1% of every minute.

\*\*\* For speeds lower than given, consult factory or your regional manager.

1. Intermittent speed and intermittent pressure must not occur simultaneously.
2. Recommended filtration is per ISO cleanliness code 20/16. A nominal filtration of 25 micron or better.
3. Recommend using a premium quality, anti-wear type mineral based hydraulic oil HLP(DIN51524) or HM ( ISO 6743/4).  
If using synthetic fluids consult the factory for alternative seal materials.
4. Recommended minimum oil viscosity 13 mm<sup>2</sup>/s [70 SUS] at 50°C [122°F].
5. Recommended maximum system operating temperature is 82°C [180°F].
6. To assure optimum motor life fill with fluid prior to loading and run at moderate load and speed for 10-15 minutes.



FUNCTION DIAGRAMS

MV 315

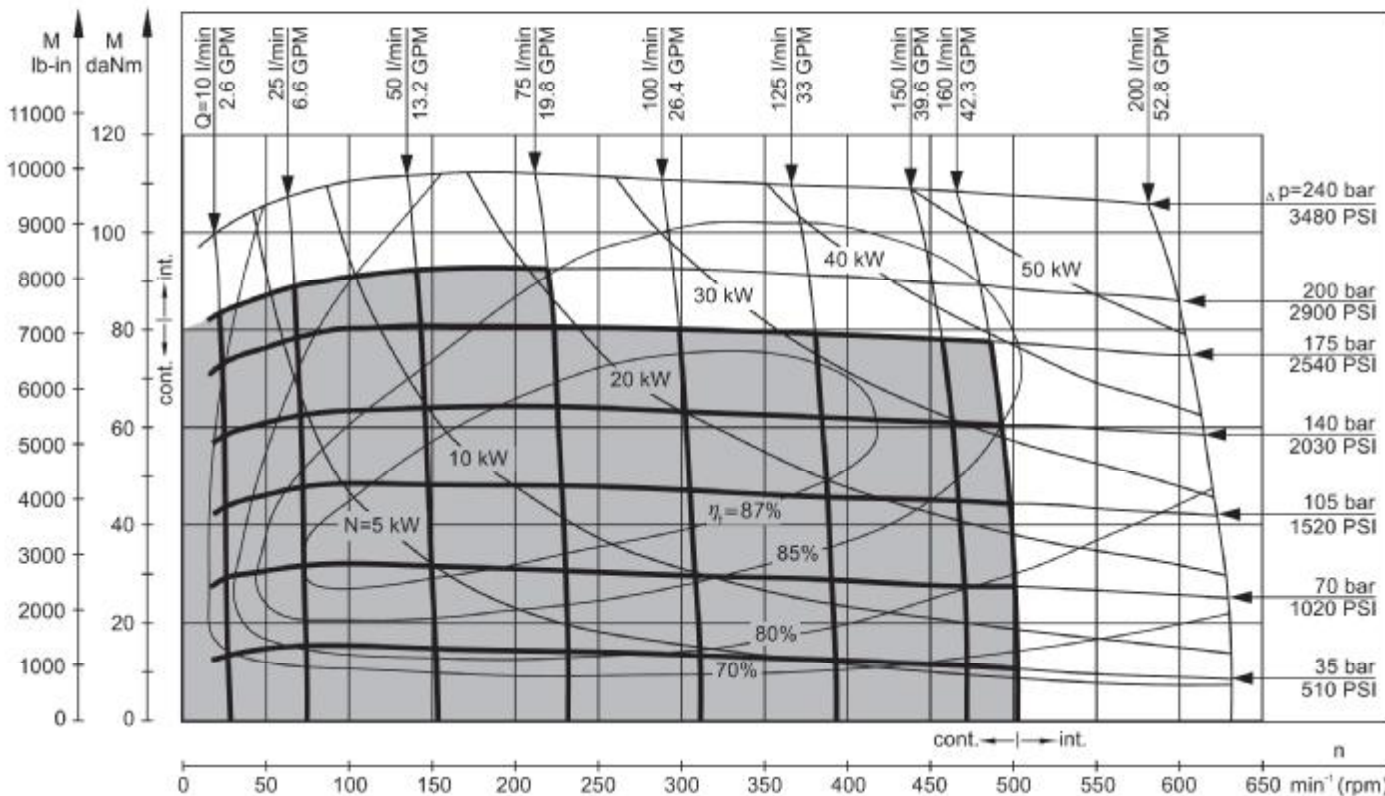

MV 400

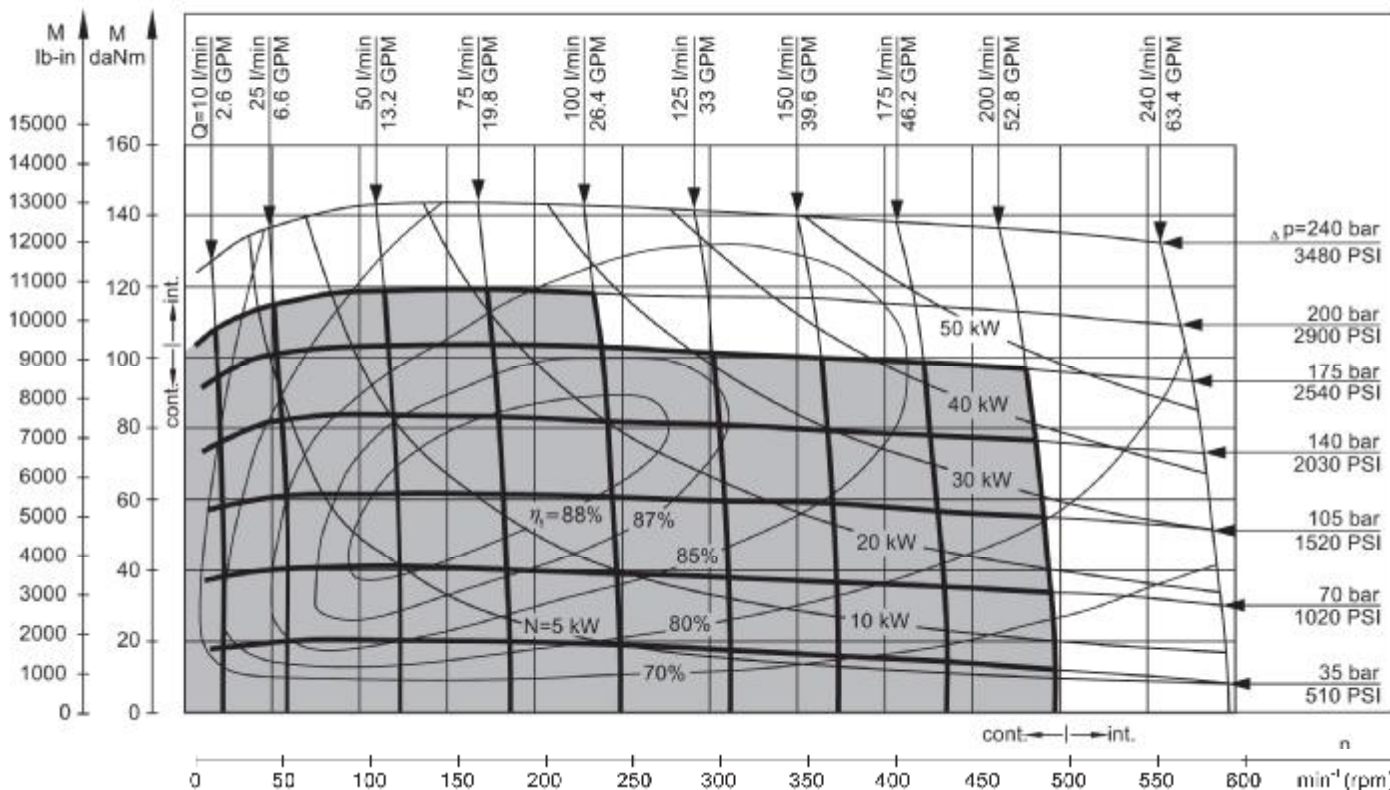

The function diagrams data is for average performance of randomly selected motors at back pressure 5+10 bar [72.5+145 PSI] and oil with viscosity of 32 mm<sup>2</sup>/s [150 SUS] at 50°C [122°F].



FUNCTION DIAGRAMS

MV 500

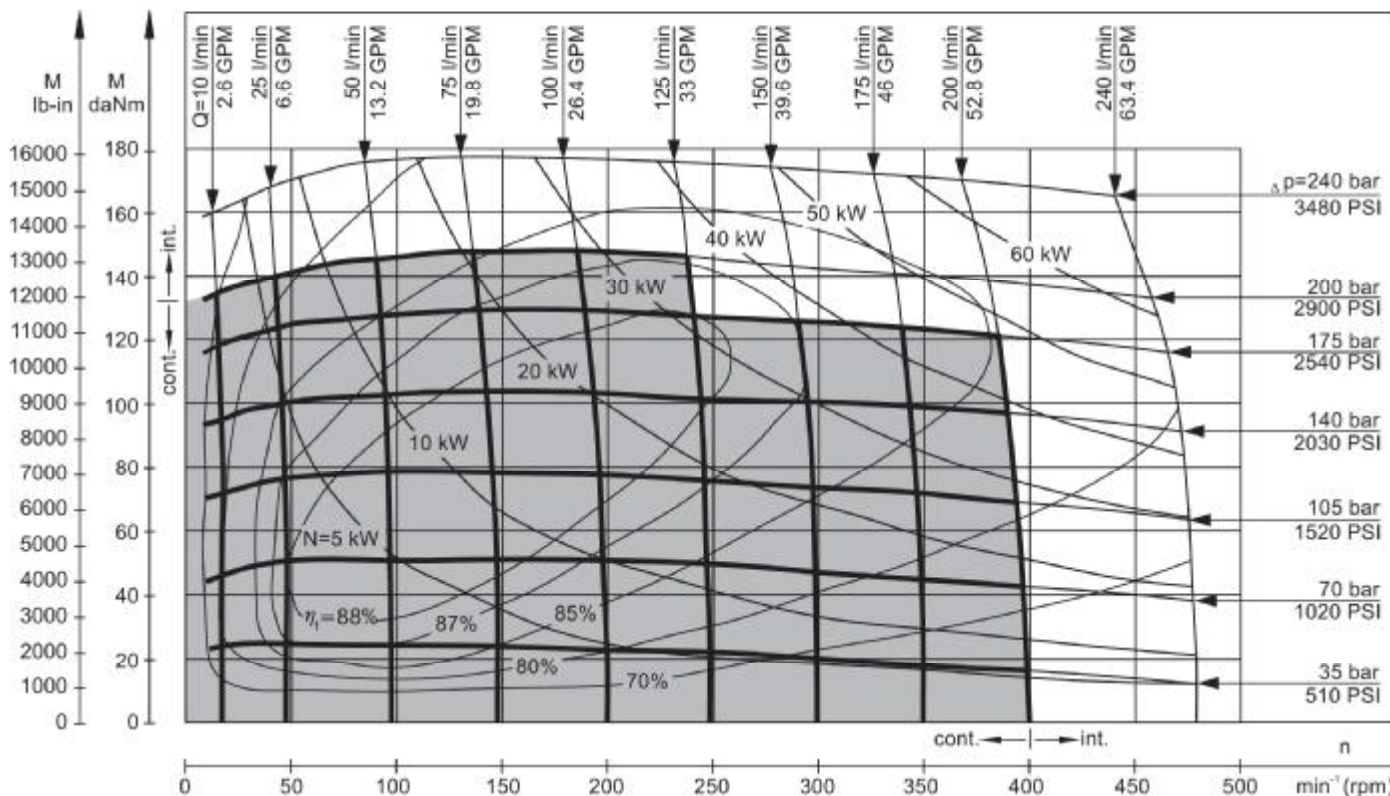

MV 630

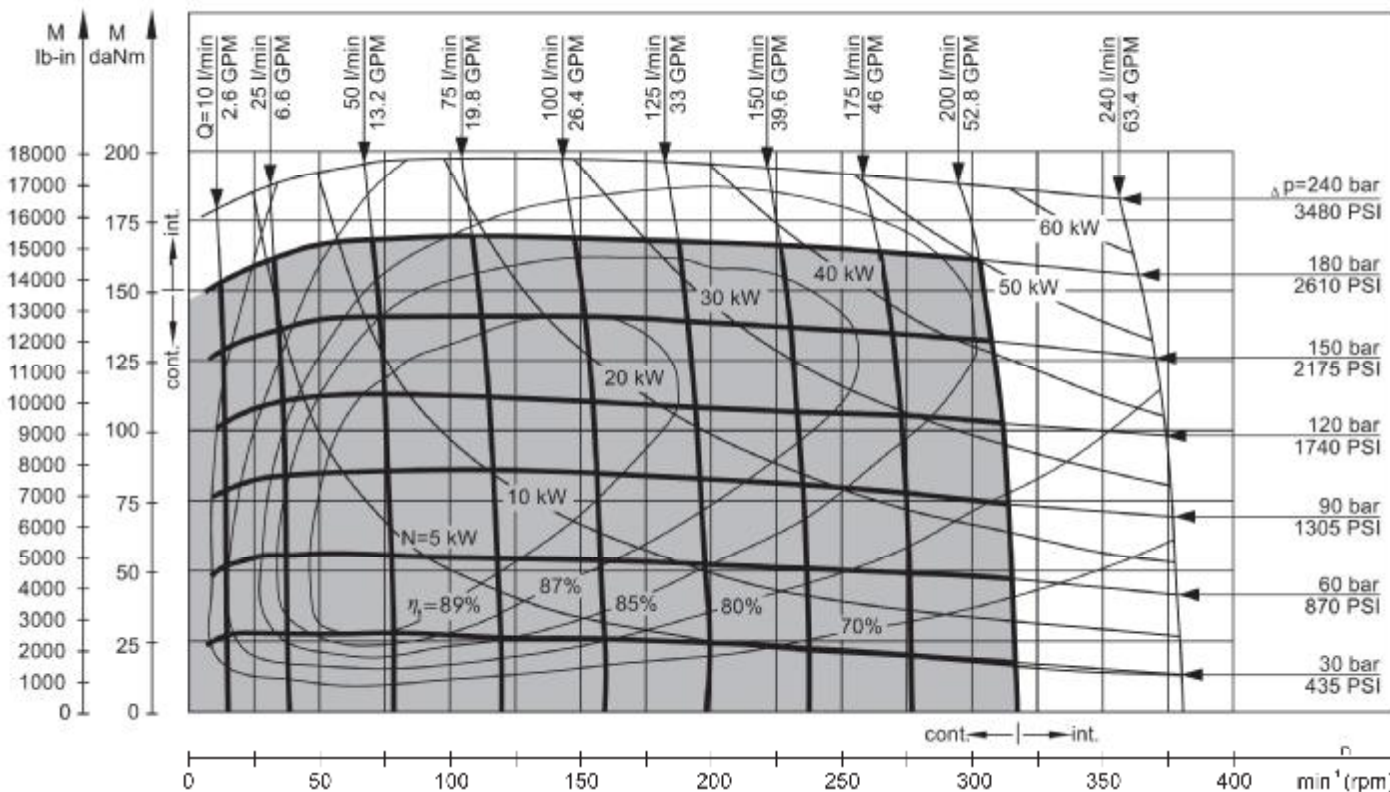

The function diagrams data is for average performance of randomly selected motors at back pressure 5+10 bar [72.5+145 PSI] and oil with viscosity of 32 mm<sup>2</sup>/s [150 SUS] at 50°C [122°F].



FUNCTION DIAGRAMS

MV 800

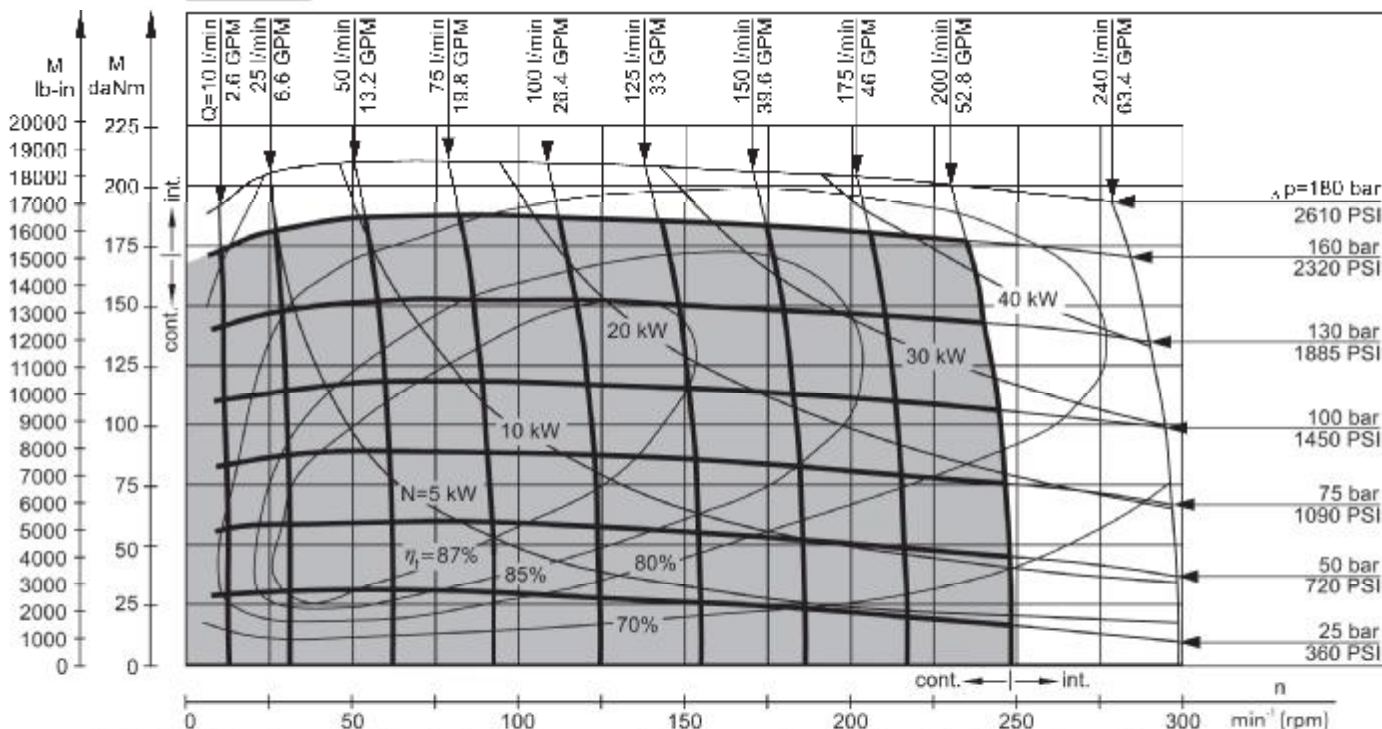

The function diagrams data is for average performance of randomly selected motors at back pressure 5+10 bar [72.5+145 PSI] and oil with viscosity of 32 mm<sup>2</sup>/s [150 SUS] at 50°C [122°F].

PERMISSIBLE SHAFT LOADS

The output shaft runs in tapered bearings that permit high axial and radial forces. The permissible radial load on the shaft is shown for an axial load of 0 N as function of the distance from the mounting flange to the point of load application. The curves apply to a B10 bearing life of 2000 hours at 100 RPM.

Curve "1" shows max. radial shaft load. Any shaft load exceeding the values shown by the curve will seriously reduce motor life.

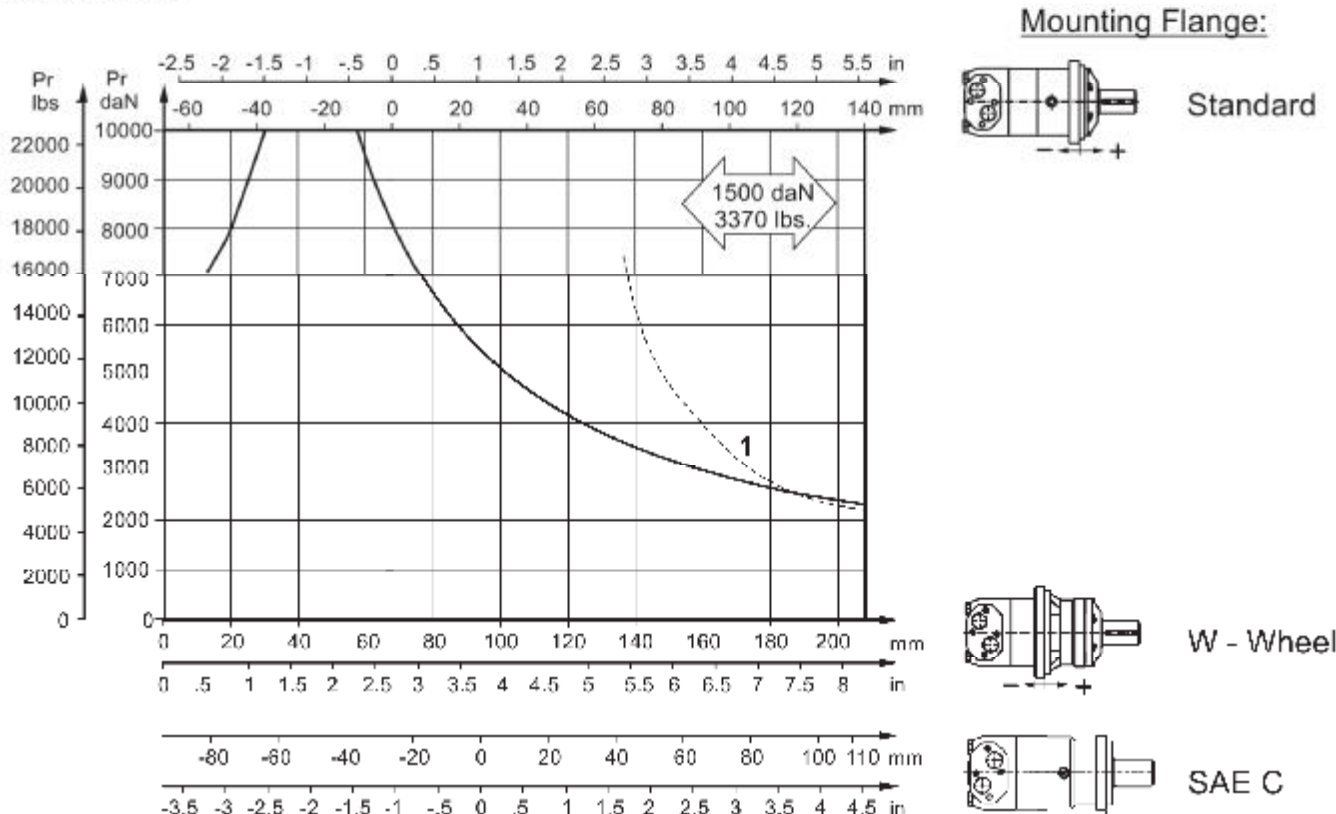



**DIMENSIONS AND MOUNTING DATA - MV and MVC**

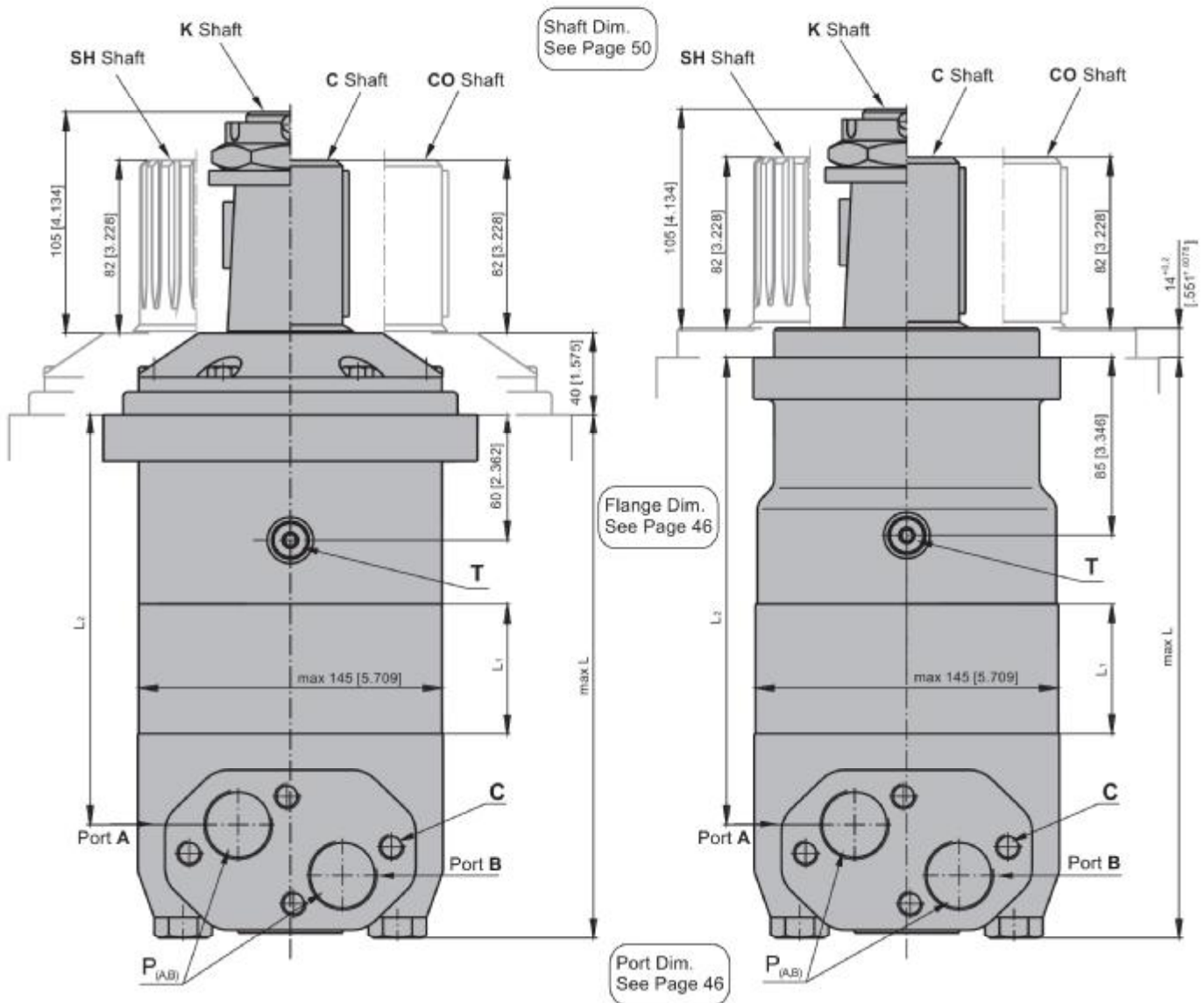

- C: 4xM12 - 12 mm [.47 in] depth
- P<sub>(A,B)</sub>: 2xG1 - 20 mm [.79 in] depth
- T: G 1/4 - 12 mm [.47 in] depth

**Standard Rotation**

Viewed from Shaft End  
 Port A Pressurized - **CW**  
 Port B Pressurized - **CCW**

**Reverse Rotation**

Viewed from Shaft End  
 Port A Pressurized - **CCW**  
 Port B Pressurized - **CW**



Type	L, mm [in]	L2, mm [in]	Type	L, mm [in]	L2, mm [in]	*L1, mm [in]
MV 315	214,5 [8.45]	160 [6.30]	MVC 315	239,0 [9.41]	185,5 [7.30]	22,0 [.87]
MV 400	221,5 [8.72]	167 [6.58]	MVC 400	246,0 [9.68]	192,5 [7.58]	29,0 [1.14]
MV 500	229,5 [9.04]	175 [6.89]	MVC 500	254,0 [10.0]	200,5 [7.89]	37,0 [1.46]
MV 630	240,0 [9.45]	186 [7.32]	MVC 630	264,5 [10.41]	211,0 [8.31]	47,5 [1.87]
MV 800	254,0 [10.0]	200 [7.87]	MVC 800	278,5 [10.96]	225,0 [8.86]	61,5 [2.42]

\* The width of the roll-gerotor is 4 mm [.157 in.] greater than L1.



**DIMENSIONS AND MOUNTING DATA - MVW**

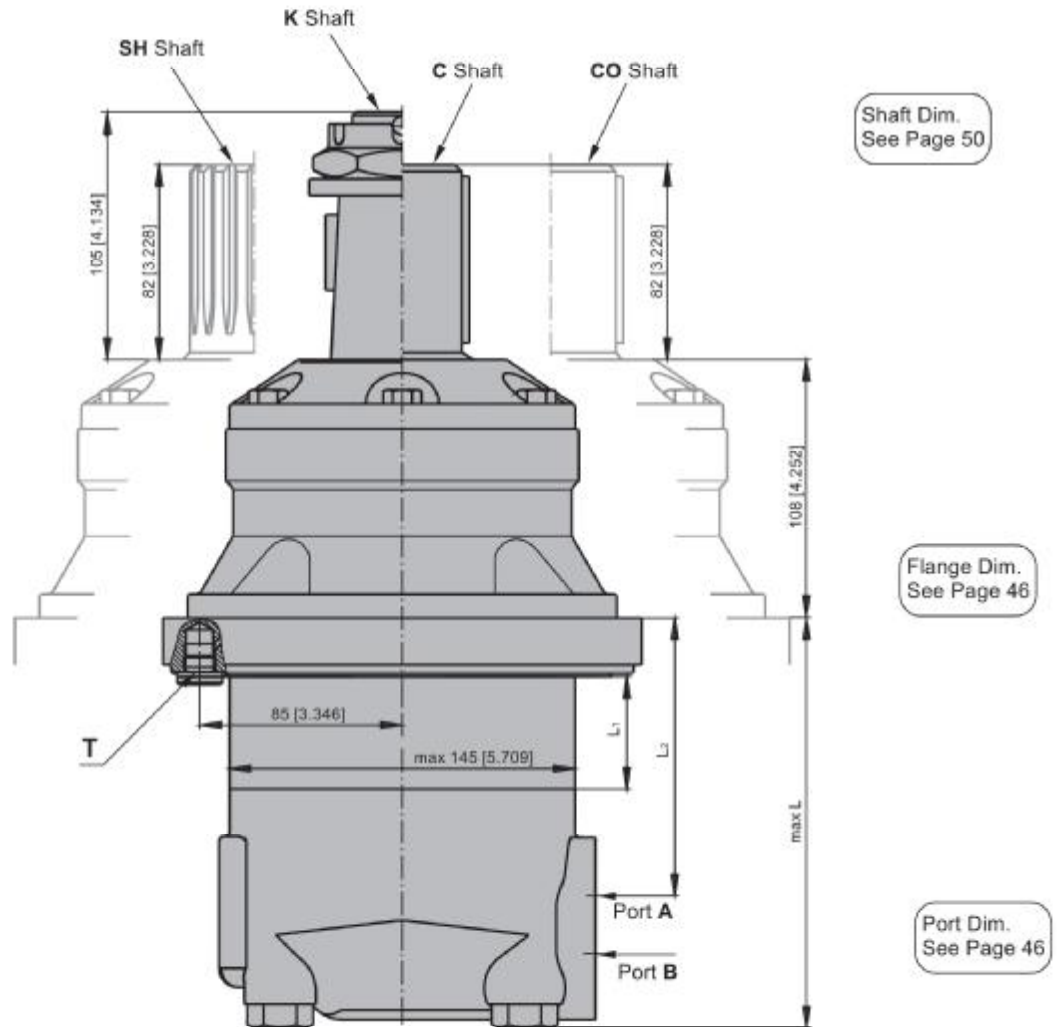

- C: 4xM12 - 12 mm [.47 in] depth
- P<sub>(A,B)</sub>: 2xG1 - 20 mm [.79 in] depth
- T: G 1/4 - 12 mm [.47 in] depth

**Standard Rotation**  
 Viewed from Shaft End  
 Port A Pressurized - **CW**  
 Port B Pressurized - **CCW**

**Reverse Rotation**  
 Viewed from Shaft End  
 Port A Pressurized - **CCW**  
 Port B Pressurized - **CW**



Type	L, mm [in]	L2, mm [in]	*L1, mm [in]
MVW 315	146 [5.75]	92 [3.62]	22,0 [ .87]
MVW 400	153 [6.02]	99 [3.90]	29,0 [1.14]
MVW 500	161 [6.34]	107 [4.21]	37,0 [1.46]
MVW 630	172 [6.77]	118 [4.65]	47,5 [1.87]
MVW 800	185 [7.28]	132 [5.20]	61,5 [2.42]



## MOUNTING

### Square Mount (4 Holes)

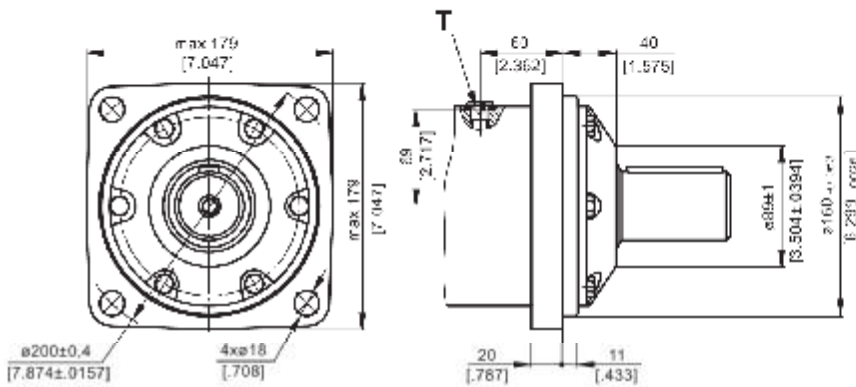

### C SAE C Mount

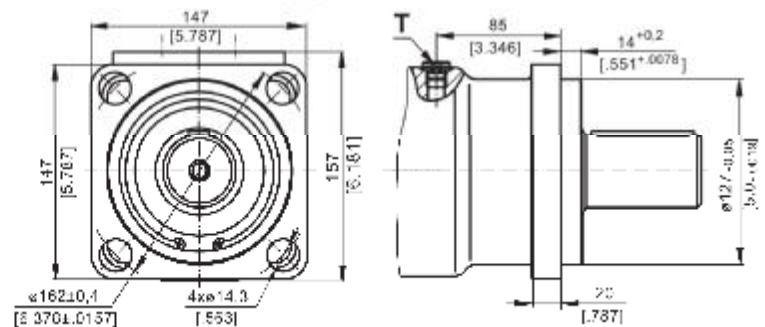

### W Wheel Mount

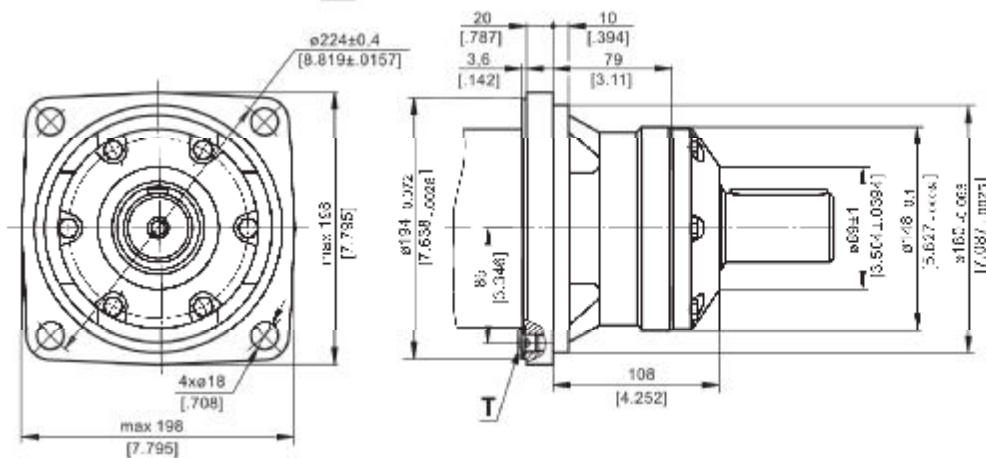

## PORTS

### Side Ports

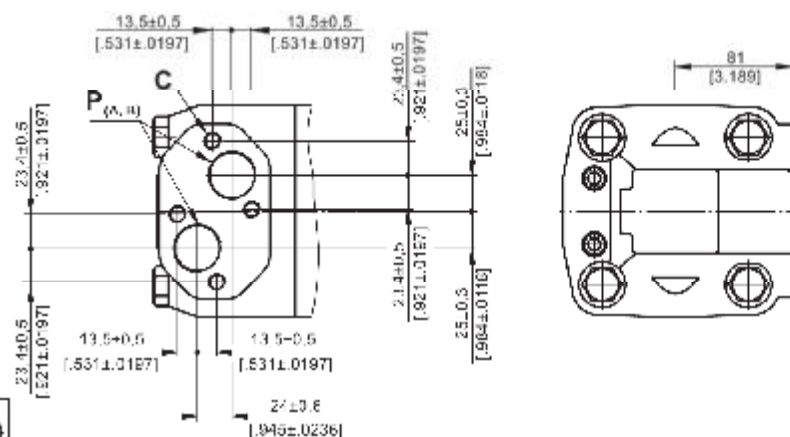

- C: 4xM12 - 12 mm [.47 in] depth
- P<sub>(A,B)</sub>: 2xG1 - 20 mm [.79 in] depth
- T: G 1/4 - 12 mm [.47 in] depth

#### Standard Rotation

Viewed from Shaft End  
 Port A Pressurized - CW  
 Port B Pressurized - CCW

#### Reverse Rotation

Viewed from Shaft End  
 Port A Pressurized - CCW  
 Port B Pressurized - CW







**DIMENSIONS AND MOUNTING**

**S Short Mount**

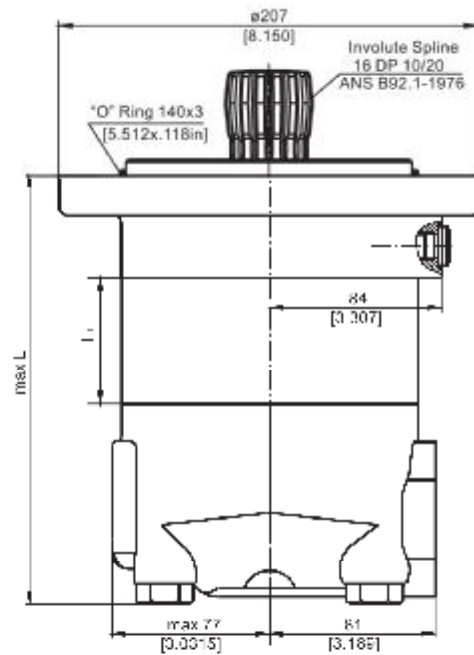
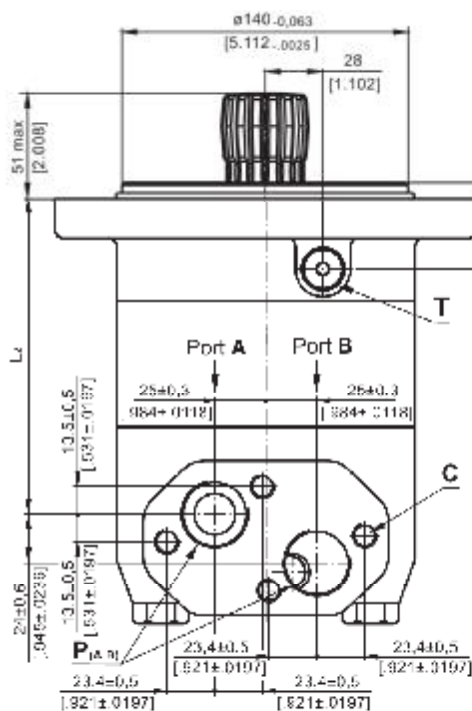

- C:** 4xM12 - 12 mm [.47 in] depth
- P<sub>(A,B)</sub>:** 2xG1 - 20 mm [.79 in] depth
- T:** G 1/4 - 12 mm [.47 in] depth

- Standard Rotation**  
Viewed from Shaft End  
Port A Pressurized - CW  
Port B Pressurized - CCW
- Reverse Rotation**  
Viewed from Shaft End  
Port A Pressurized - CCW  
Port B Pressurized - CW

Type	L, mm [in]	L <sub>2</sub> , mm [in]	*L <sub>1</sub> , mm [in]
MVS 315	171[6.73]	117[4.61]	22,0 [.87]
MVS 400	179[7.05]	124[4.88]	29,0 [1.14]
MVS 500	186[7.32]	132[5.20]	37,0 [1.46]
MVS 630	197[7.76]	143[5.63]	47,5 [1.87]
MVS 800	211[8.31]	157[6.18]	61,5 [2.42]

\* The width of the roll-gerotor is 4 mm [.157 in] greater than L<sub>1</sub>.

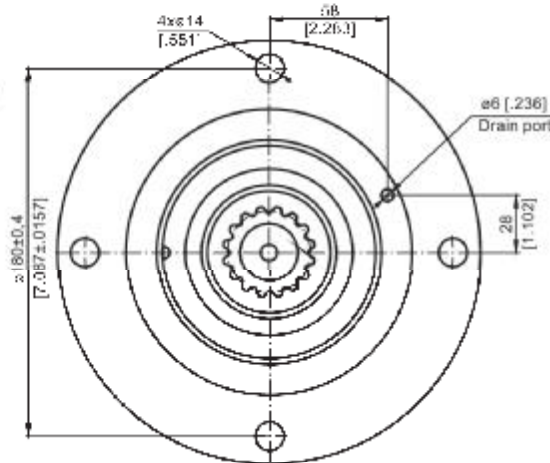

**DIMENSIONS OF THE ATTACHED COMPONENT**

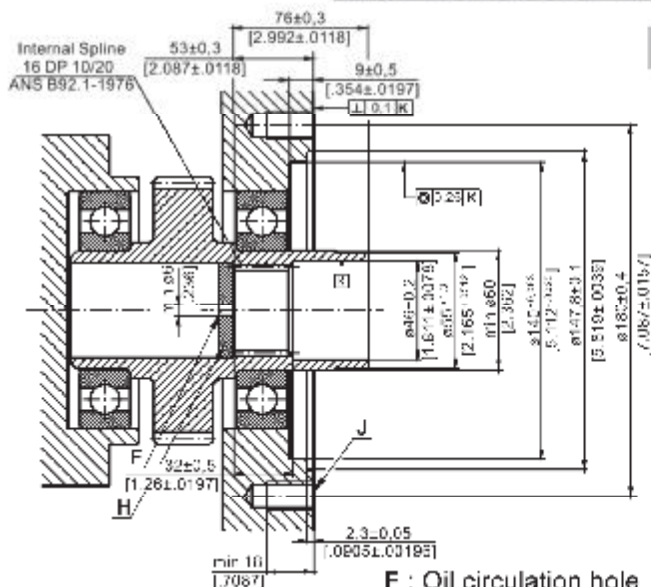

**MVS**

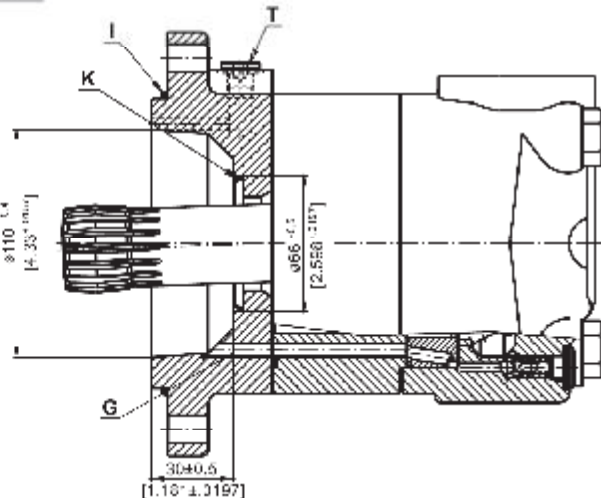

- F:** Oil circulation hole
- G:** Internal drain channel
- H:** Hardened stop plate
- J:** 4xM12-18 mm [.709 in] depth, 90°
- K:** Conical seal ring
- T:** Drain connection G 1/4 - 12 mm [.47 in] depth



**DIMENSIONS AND MOUNTING**

**V** Very Short Mount

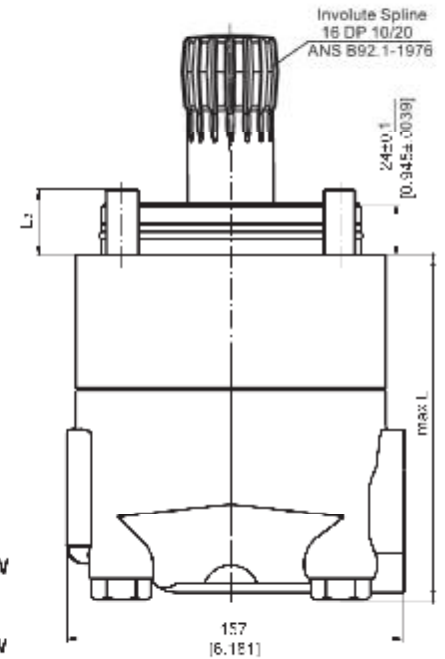
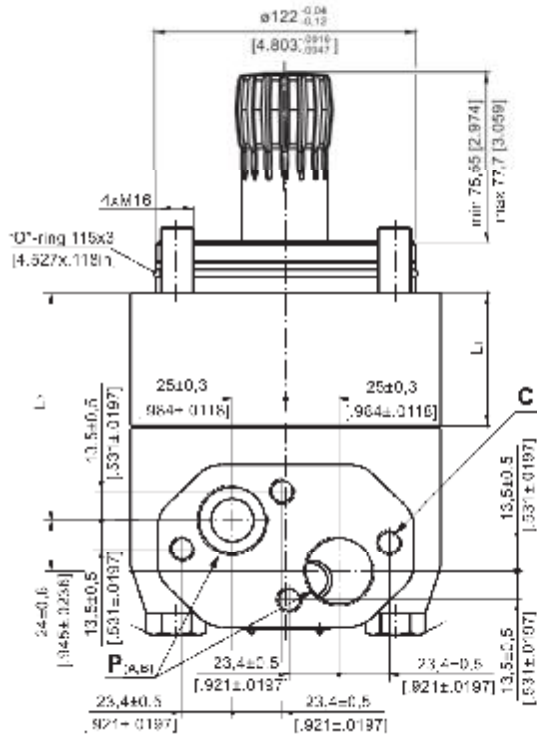

**Standard Rotation**  
Viewed from Shaft End  
Part A Pressurized - CW  
Part B Pressurized - CCW

**Reverse Rotation**  
Viewed from Shaft End  
Part A Pressurized - CCW  
Part B Pressurized - CW

**C:** 4xM12 - 12 mm [.47 in] depth  
**P<sub>(A,B)</sub>:** 2xG1 - 20 mm [.79 in] depth

Type	L, mm[in.]	L2, mm [in.]	L3, mm [in.]	*L1, mm [in.]
MVV 315	121,5[4.78]	68[2.68]	29,5[1.16]	22,0 [.87]
MVV 400	128,5[5.06]	75[2.95]	32,5[1.28]	29,0 [1.14]
MVV 500	136,5[5.37]	83[3.27]	34,5[1.36]	37,0 [1.46]
MVV 630	147,0[5.79]	93[3.66]	34,0[1.34]	47,5 [1.87]
MVV 800	161,0[6.34]	107,5[4.23]	30,0[1.18]	61,5 [2.42]

\* The width of the roll-gerotor is 4 mm [.157 in] greater than L1.

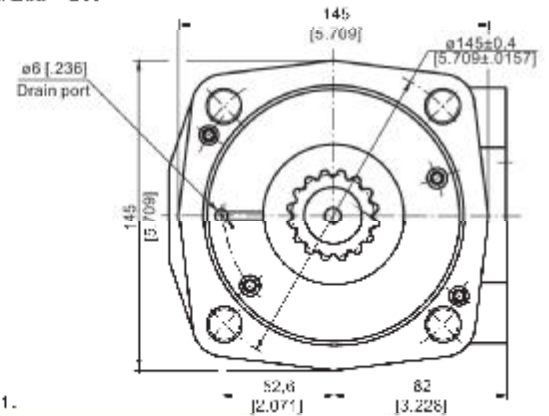

**DIMENSIONS OF THE ATTACHED COMPONENT**

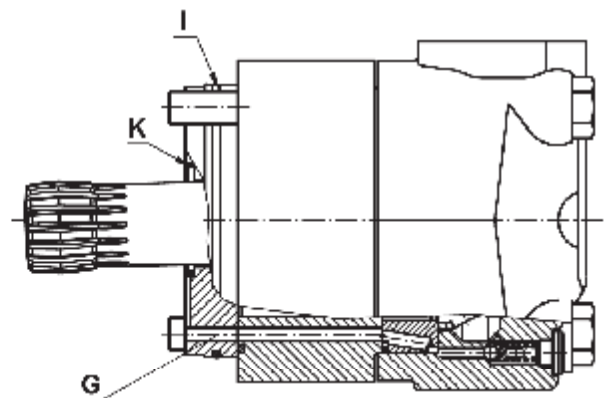
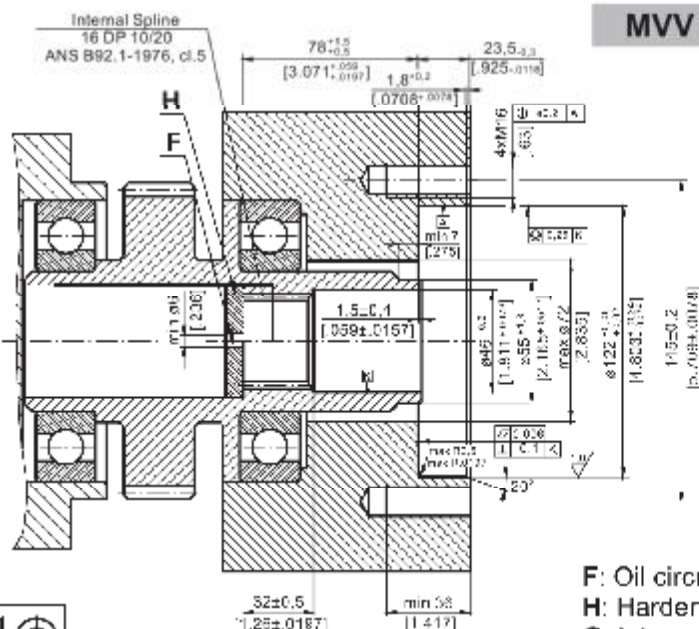

**F:** Oil circulation hole  
**H:** Hardened stop plate  
**G:** Internal drain channel

**I:** O-Ring 115x3mm [4.527x.118in]  
**K:** Conical seal ring







**SHAFT EXTENSIONS**

**C** -  $\varnothing 50$  straight, Parallel key A14x9x70 DIN 6885

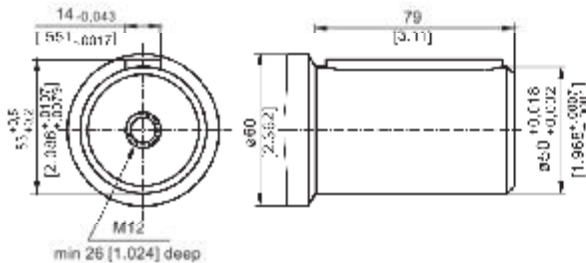

**CO** -  $\varnothing 2\frac{1}{4}$ " [57,15] straight, Parallel key  $\frac{1}{2}$ " x  $\frac{1}{2}$ " x  $2\frac{1}{4}$ " BS46

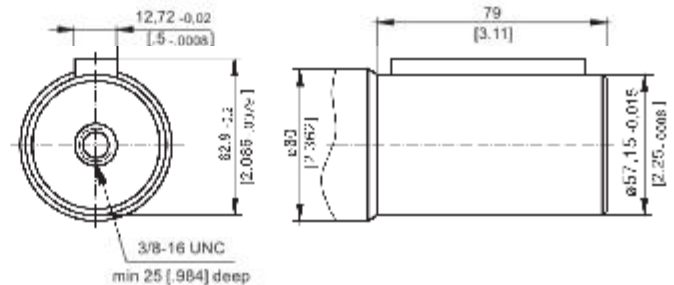

**SH** -  $\varnothing 2\frac{1}{8}$ " splined, 16 DP 8/16 ANS B92.1-1976

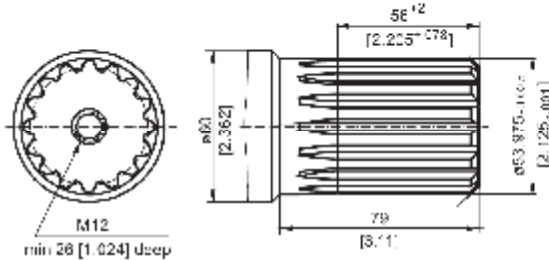

**K** - tapered 1:10, Parallel key B16x10x32 DIN 6885

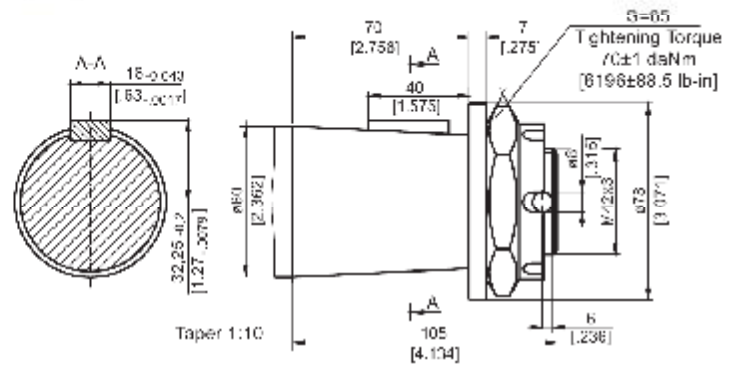

**ORDER CODE**

	1	2	3	4	5	6
<b>M V</b>						

**Pos.1 - Mounting Flange**

omit - Square mount, four holes

- C** - SAE C mount
- W** - Wheel mount
- S** - Short mount
- V** - Very short mount

**Pos.2 - Displacement code**

- 315** - 314,5 cm<sup>3</sup>/rev [19.18 in<sup>3</sup>/rev]
- 400** - 400,9 cm<sup>3</sup>/rev [24.45 in<sup>3</sup>/rev]
- 500** - 499,6 cm<sup>3</sup>/rev [30.48 in<sup>3</sup>/rev]
- 630** - 629,1 cm<sup>3</sup>/rev [38.38 in<sup>3</sup>/rev]
- 800** - 801,8 cm<sup>3</sup>/rev [48.91 in<sup>3</sup>/rev]

**Pos. 3 - Shaft extensions\***

omit - for **S** and **V** mounting flange

- C** -  $\varnothing 50$  straight, Parallel key A14x9x70 DIN6885
- CO** -  $\varnothing 2\frac{1}{4}$ " straight, Parallel key  $\frac{1}{2}$ " x  $\frac{1}{2}$ " x  $2\frac{1}{4}$ " BS46
- SH** -  $\varnothing 2\frac{1}{8}$ " splined, ANS B92.1-1976
- K** -  $\varnothing 60$  tapered 1:10, Parallel key B16x10x32 DIN6885

**Pos. 4 - Shaft Seal Version (see page 49)**

- omit - Low pressure shaft seal
- U** - High pressure shaft seal

**Pos. 5 - Special Features (see page 51)**

**Pos. 6 - Design Series**

omit - Factory specified

**NOTES:**

\* The permissible output torque for shafts must not be exceeded!

The hydraulic motors are manganophosphatized as standard.