

# HYDRAULIC MOTORS MH

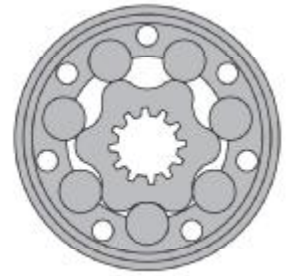

## APPLICATION

- » Conveyors
- » Feeding mechanism of robots and manipulators
- » Metal working machines
- » Textile machines
- » Agricultural machines
- » Food industries
- » Mining machinery etc.



## CONTENTS

Specification data .....	94
Function diagrams .....	95+97
Permissible shaft loads .....	97
Dimensions and mounting .....	98
Permissible shaft seal pressure.....	99
Tacho connection.....	100
Shaft extensions .....	100
Order code .....	101

## OPTIONS

- » Model - Spool valve, roll-gerotor
- » Flange mount
- » Shafts - straight, splined and tapered
- » Metric and BSPP ports
- » Other special features

## GENERAL

Max. Displacement, cm <sup>3</sup> /rev [in <sup>3</sup> /rev]	502,4 [30.7]
Max. Speed, [RPM]	445
Max. Torque, daNm [lb-in]	cont.: 84 [7434] int.: 104 [9204]
Max. Output, kW [HP]	18,5 [24.8]
Max. Pressure Drop, bar [PSI]	cont.: 175 [2540] int.: 200 [2900]
Max. Oil Flow, lpm [GPM]	90 [23.78]
Min. Speed, [RPM]	5
Pressure fluid	Mineral based- HLP(DIN 51524) or HM(ISO 6743/4)
Temperature range, °C [°F]	-40+140 [-40+284]
Optimal Viscosity range, mm <sup>2</sup> /s [SUS]	20÷75 [98÷347]
Filtration	ISO code 20/16 (Min. recommended fluid filtration of 25 microns)

Oil flow in drain line

Pressure drop bar [PSI]	Viscosity mm <sup>2</sup> /s [SUS]	Oil flow in drain line lpm [GPM]
100 [1450]	20 [98]	2,5 [.660]
	35 [164]	1,8 [.476]
140 [2030]	20 [98]	3,5 [.925]
	35 [164]	2,8 [.740]

Pressure Losses

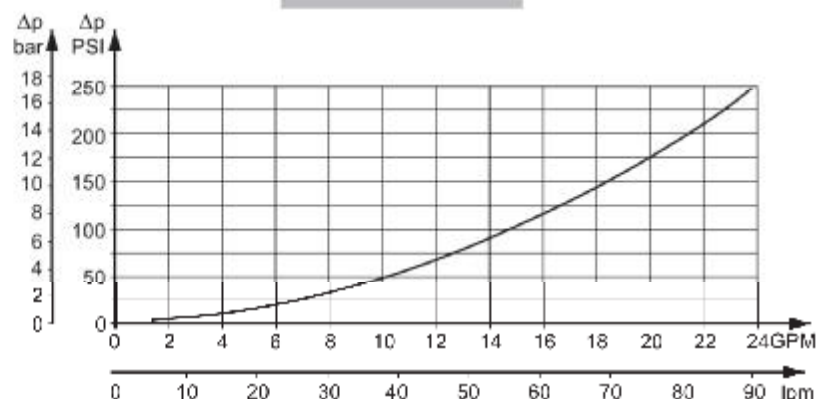



**SPECIFICATION DATA**

Type		MH 200	MH 250	MH 315	MH 400	MH 500
<b>Displacement, cm<sup>3</sup>/rev [in<sup>3</sup>/rev]</b>		201,3 [12.3]	252 [15.4]	314,9 [19.2]	396,8 [24.2]	502,4 [30.7]
<b>Max. Speed, [RPM]</b>	Cont.	370	295	235	185	150
	Int.*	445	350	285	225	180
<b>Max. Torque daNm [lb-in]</b>	Cont.	51 [4510]	61 [5398]	74 [6548]	84 [7434]	82 [7257]
	Int.*	58 [5130]	70 [6195]	82 [7257]	98 [8673]	104 [9204]
	Peak**	64 [5064]	79 [6992]	98 [8673]	109 [9647]	117 [10350]
<b>Max. Output kW [HP]</b>	Cont.	16 [21]	16 [21]	14 [18.7]	12,5 [16.7]	11 [14.7]
	Int.*	18,5 [24.8]	18,5 [24.8]	15,5 [20.7]	15 [20.1]	14 [18.7]
<b>Max. Pressure Drop bar [PSI]</b>	Cont.	175 [2540]	175 [2540]	175 [2540]	155 [2240]	125 [1810]
	Int.*	200 [2900]	200 [2900]	200 [2900]	190 [2750]	160 [2320]
	Peak**	225 [3260]	225 [3260]	225 [3260]	210 [3045]	180 [2610]
<b>Max. Oil Flow lpm [GPM]</b>	Cont.	75 [19.81]	75 [19.81]	75 [19.81]	75 [19.81]	75 [19.81]
	Int.*	90 [23.78]	90 [23.78]	90 [23.78]	90 [23.78]	90 [23.78]
<b>Max. Inlet Pressure bar [PSI]</b>	Cont.	200 [2900]	200 [2900]	200 [2900]	200 [2900]	200 [2900]
	Int.*	225 [3260]	225 [3260]	225 [3260]	225 [3260]	225 [3260]
	Peak**	250 [3626]	250 [3626]	250 [3626]	250 [3626]	250 [3626]
<b>Max. Starting Pressure with Unloaded Shaft, bar [PSI]</b>		5 [72]	5 [72]	5 [72]	5 [72]	5 [72]
<b>Min. Starting Torque, daNm [lb-in]</b>	At max.press.dropCont	39 [3450]	52 [4600]	66 [5840]	72 [6370]	72 [6370]
	At max.press.drop Int.*	45 [3980]	59 [5221]	73 [6460]	88 [7788]	88 [7788]
<b>Min. Speed***, [RPM]</b>		10	10	8	5	5
<b>Weight, kg [lb]</b>		10,5 [23.2]	11 [24.3]	11,5 [25.4]	12,3 [27.1]	13 [28.7]

\* Intermittent operation: the permissible values may occur for max. 10% of every minute.

\*\* Peak load: the permissible values may occur for max. 1% of every minute.

\*\*\* For speeds lower than given, consult factory or your regional manager.

- Intermittent speed and intermittent pressure must not occur simultaneously.
- Recommended filtration is per ISO cleanliness code 20/16. A nominal filtration of 25 micron or better.
- Recommend using a premium quality, anti-wear type mineral based hydraulic oil HLP(DIN51524) or HM ( ISO 6743/4). If using synthetic fluids consult the factory for alternative seal materials.
- Recommended minimum oil viscosity 13 mm<sup>2</sup>/s [70 SUS] at 50°C [122°F].
- Recommended maximum system operating temperature is 82°C [180°F].
- To assure optimum motor life fill with fluid prior to loading and run at moderate load and speed for 10-15 minutes.



FUNCTION DIAGRAMS

MH 200

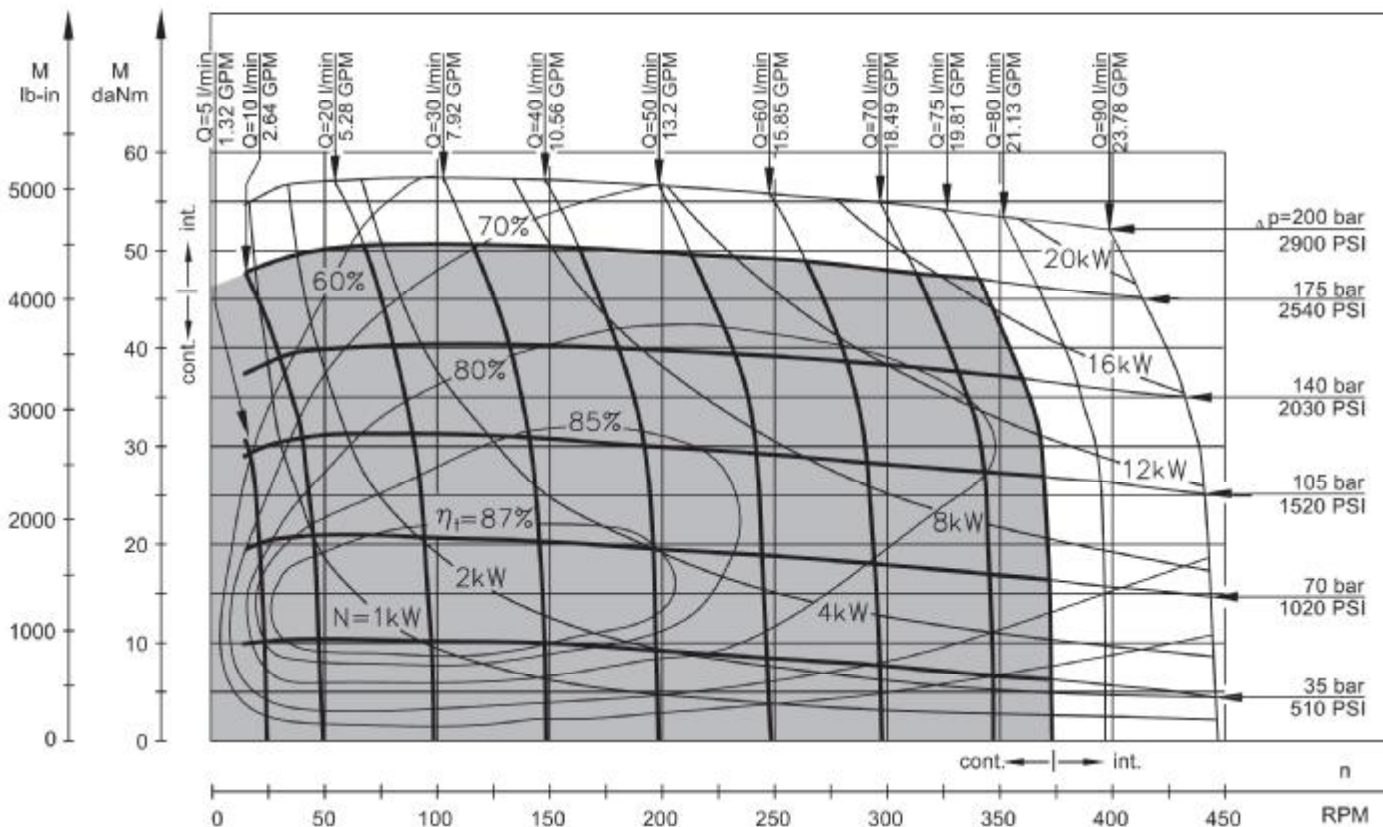

MH 250

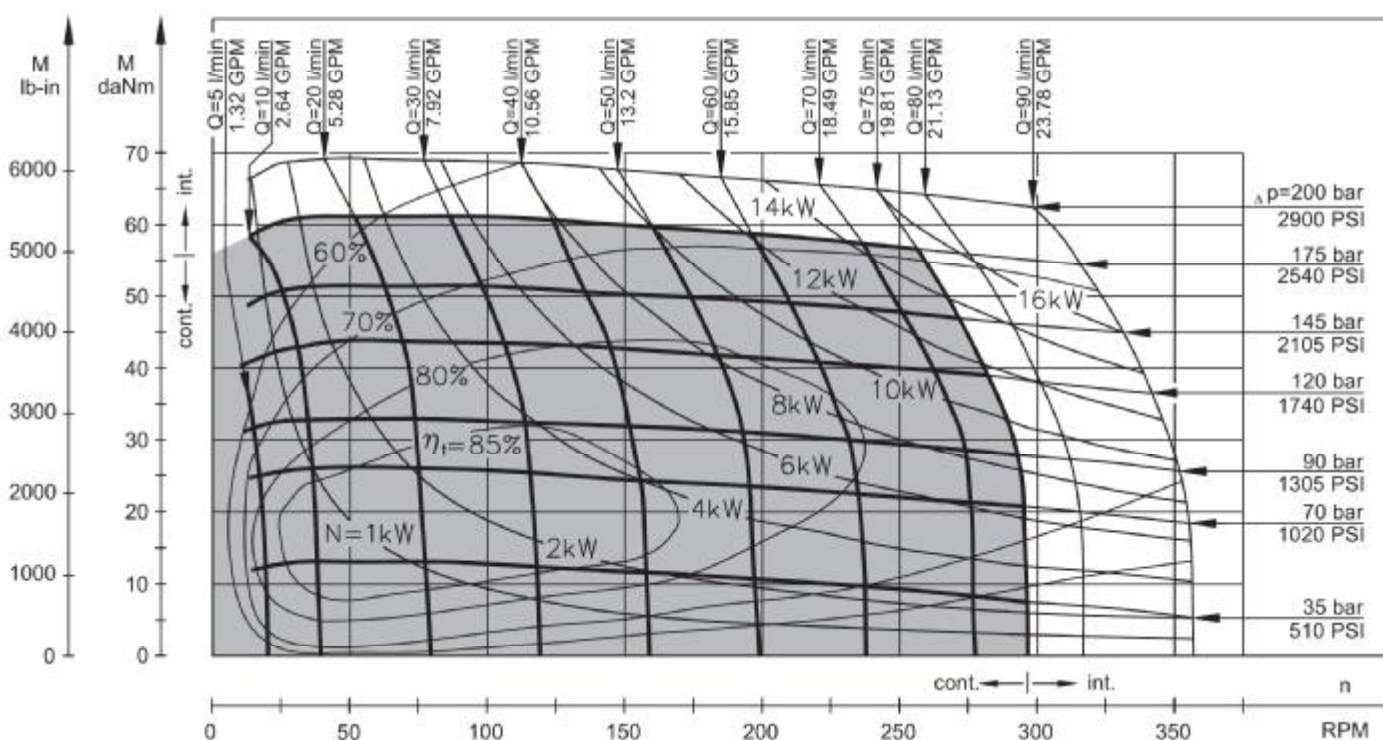

The function diagrams data is for average performance of randomly selected motors at back pressure 5+10 bar [72.5+145 PSI] and oil with viscosity of 32 mm<sup>2</sup>/s [150 SUS] at 50°C [122°F]



FUNCTION DIAGRAMS

MH 315

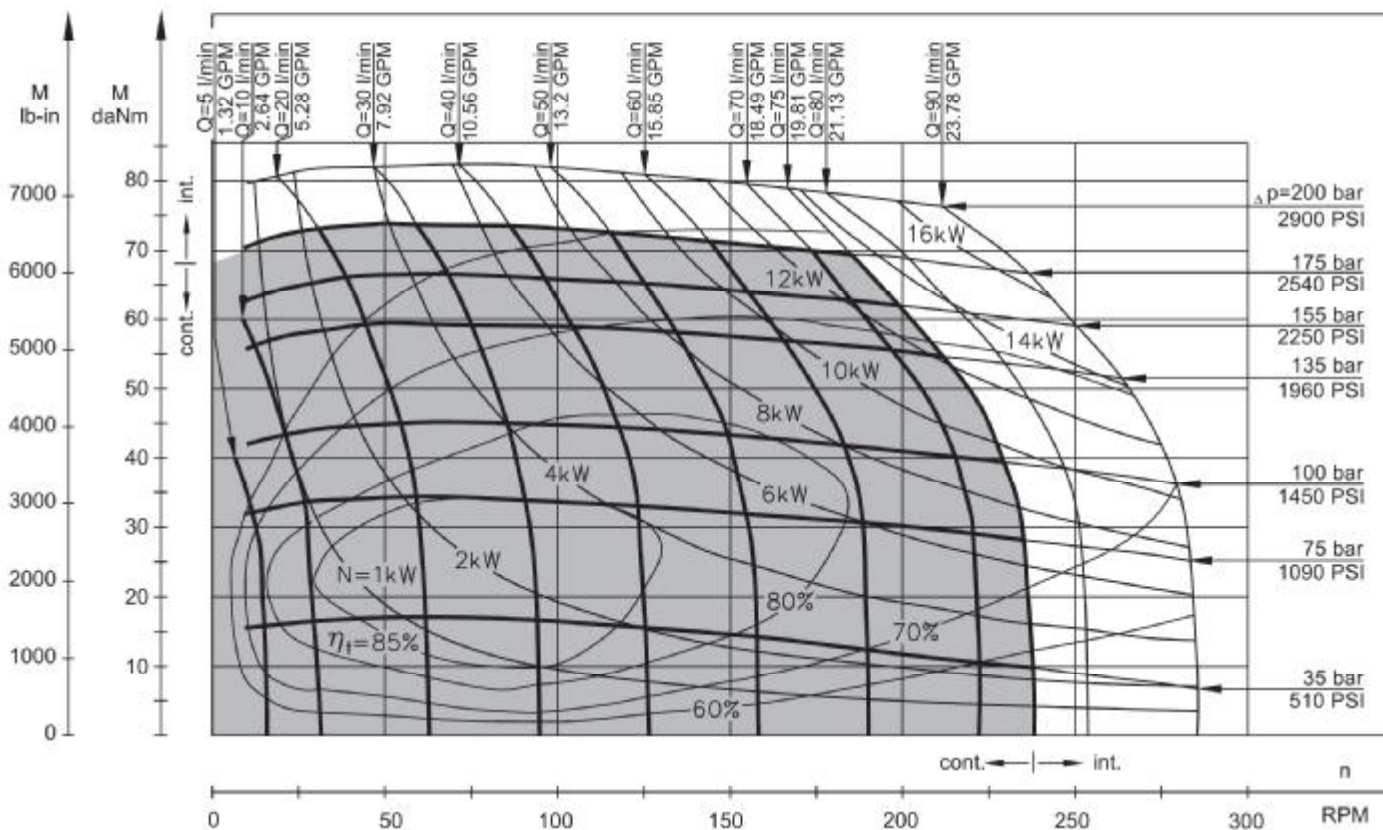

MH 400

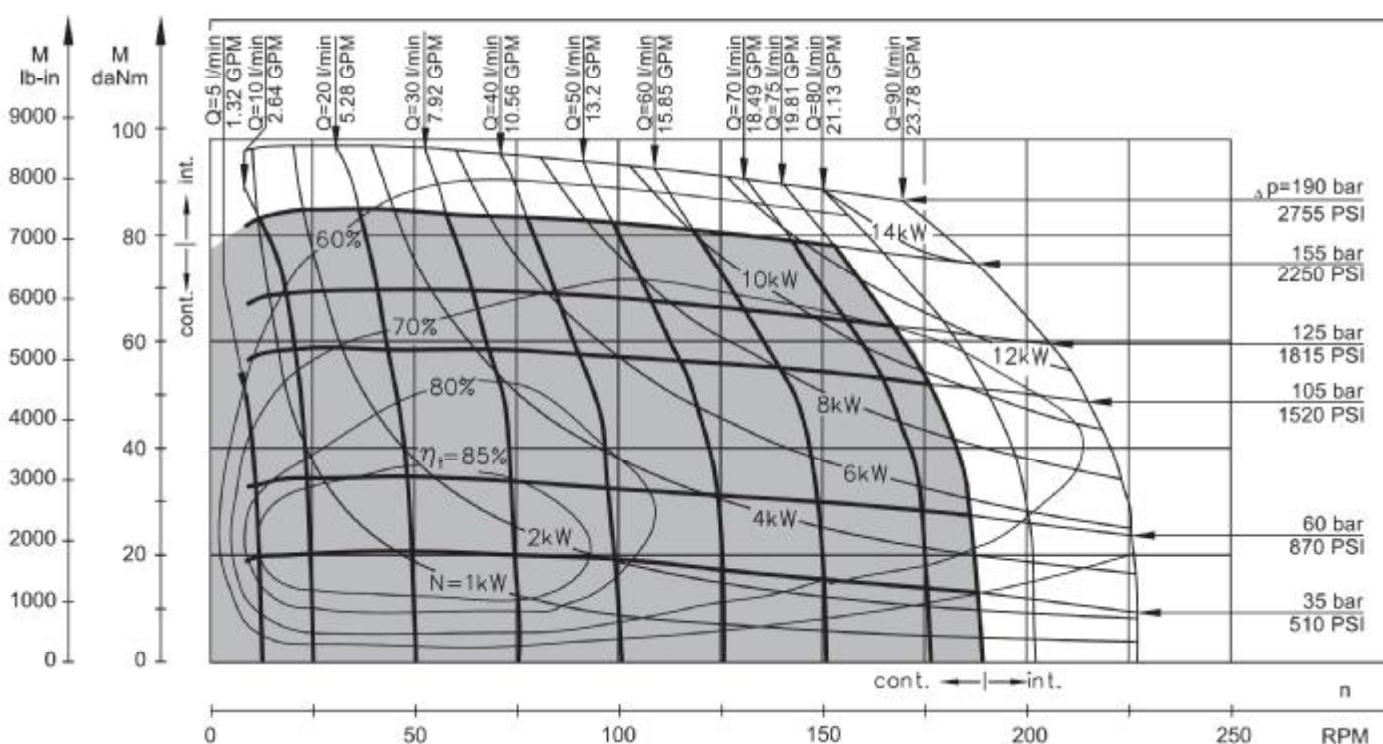

The function diagrams data is for average performance of randomly selected motors at back pressure 5+10 bar [72.5+145 PSI] and oil with viscosity of 32 mm<sup>2</sup>/s [150 SUS] at 50°C [122°F]



FUNCTION DIAGRAMS

MH 500

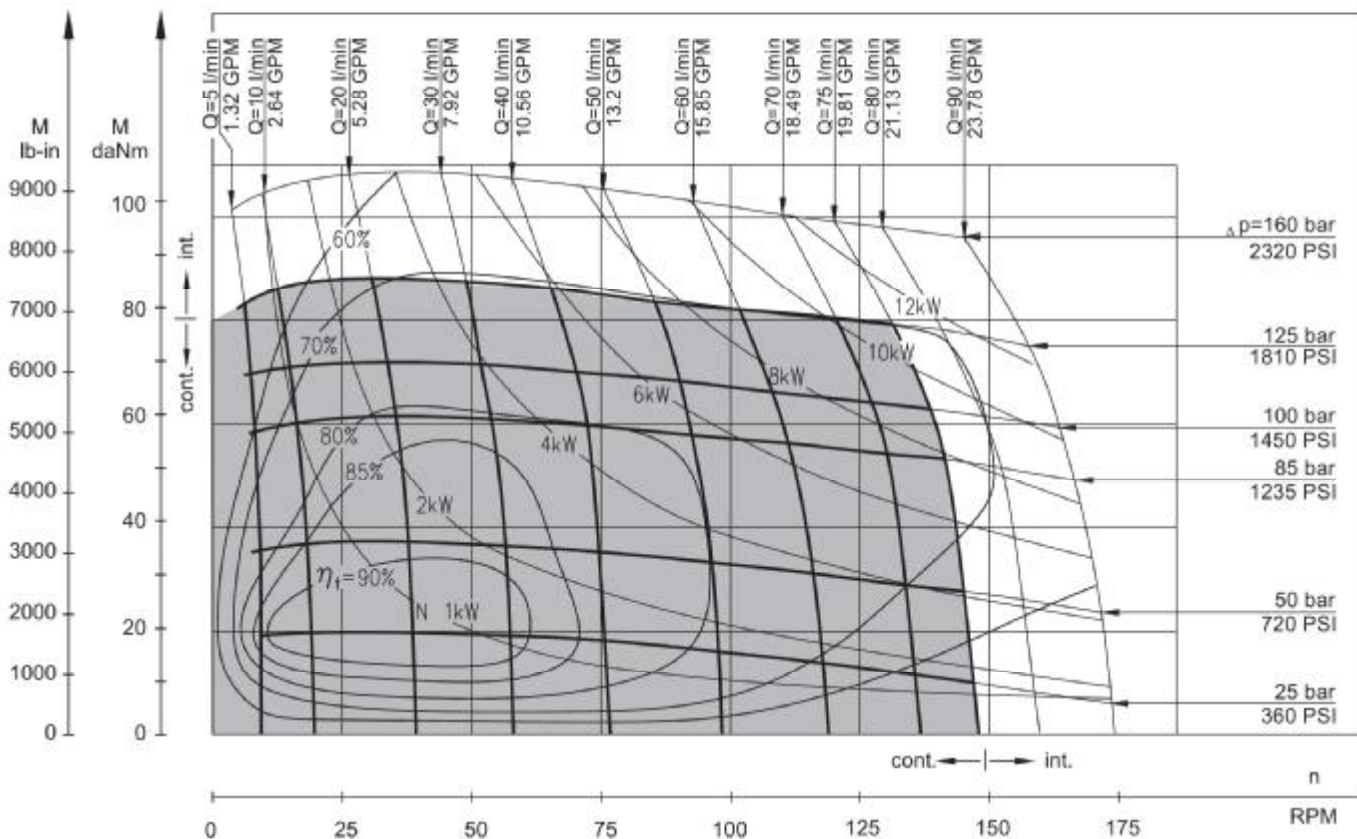

The function diagrams data is for average performance of randomly selected motors at back pressure 5+10 bar [72.5+145 PSI] and oil with viscosity of 32 mm<sup>2</sup>/s [150 SUS] at 50°C [122°F].

PERMISSIBLE SHAFT LOADS FOR MH MOTORS

The permissible radial shaft load  $P_{rad}$  depends on the speed (RPM) and distance (L) from the point of load to the mounting flange.

$$\text{Radial Shaft Load } P_{rad} = \frac{1100}{n} \times \frac{25000}{103,5+L}, \text{ daN}^*$$

[\*L in mm; L ≤ 60 mm; n > 200 RPM]

$$\text{Radial Shaft Load } P_{rad} = \frac{1100}{\text{RPM}} \times \frac{2215}{4,075+L}, \text{ lbs}^{**}$$

[\*\*L in inch; L < 2.36 in; n ≥ 200 RPM]

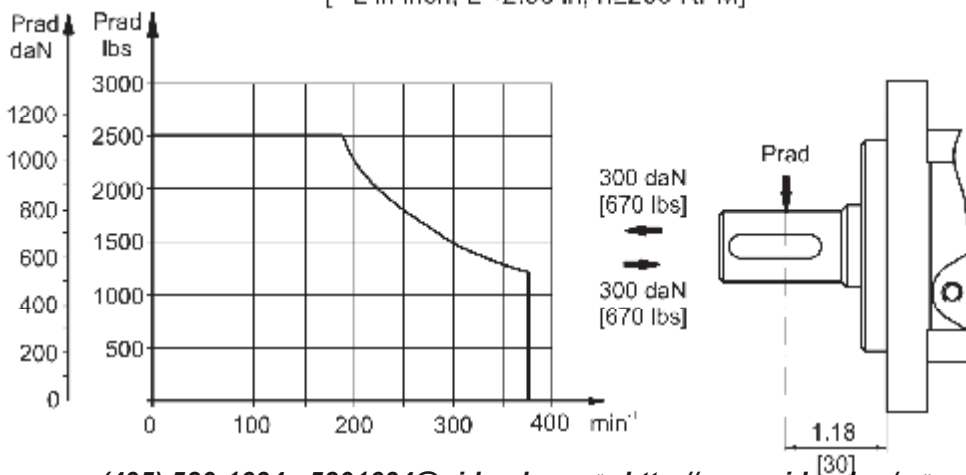



**DIMENSIONS AND MOUNTING DATA**

Magneto Mount (4 holes)

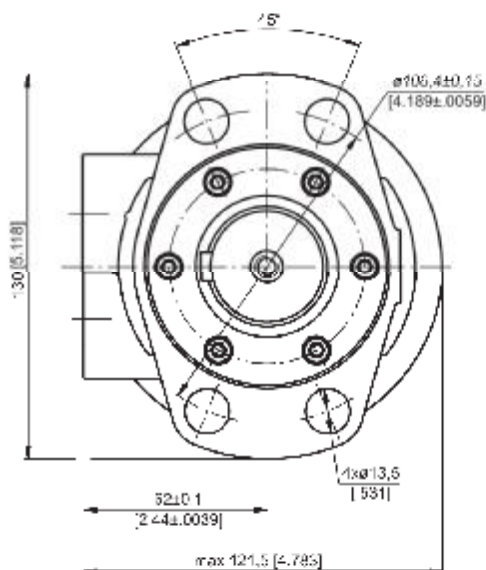
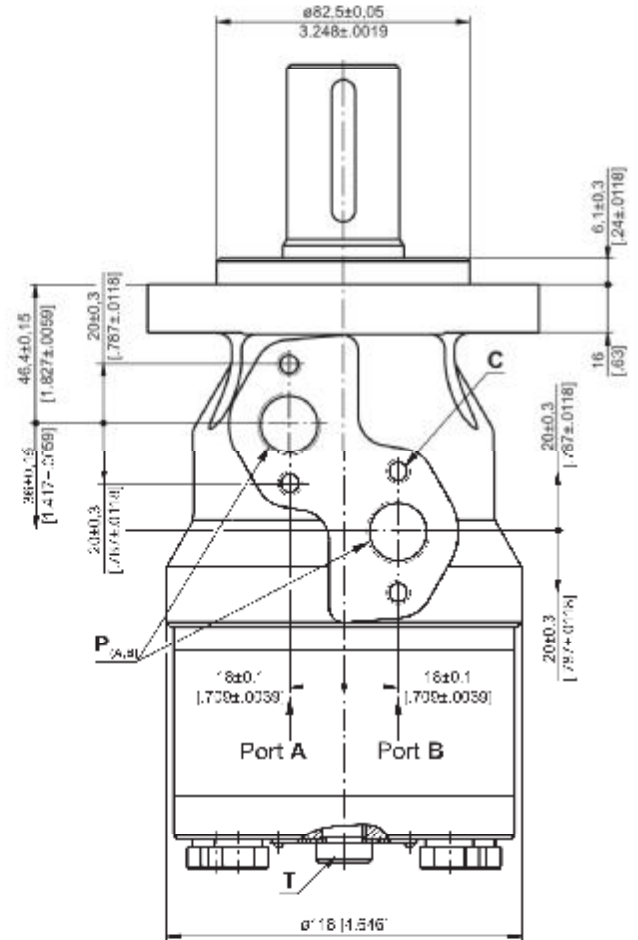
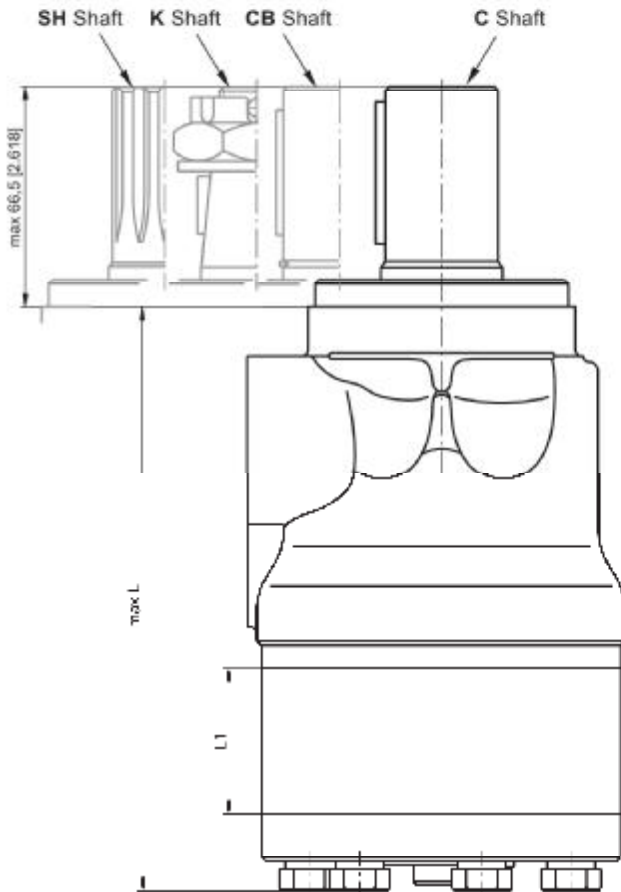

Type	L, mm [in]	L <sub>1</sub> , mm [in]
MH 200	169 [6.65]	27,8 [1.09]
MH 250	176 [6.93]	34,8 [1.37]
MH 315	184 [7.24]	43,5 [1.71]
MH 400	196 [7.72]	54,8 [2.16]
MH 500	211 [8.31]	69,4 [2.73]

- C** : 4xM8-13 mm [.51 in] depth
- P<sub>A, B</sub>** : 2xG1/2 or 2xM22x1,5-15 mm [.59 in] depth
- T** : G1/4 or M14x1,5-12 mm [.47 in] depth (plugged)

**Standard Rotation**  
Viewed from Shaft End  
Port A Pressurized - **CW**  
Port B Pressurized - **CCW**

**Reverse Rotation**  
Viewed from Shaft End  
Port A Pressurized - **CCW**  
Port B Pressurized - **CW**





**MAX. PERMISSIBLE SHAFT SEAL PRESSURE FOR MH MOTORS**

**MH...U1 motors with high pressure seal and without drain connection:**

The shaft seal pressure equals the average of input pressure and return pressure.

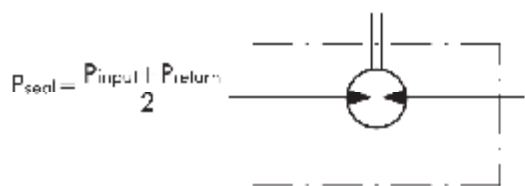

**MH...U motors with high pressure seal and drain connection:**

The shaft seal pressure equals the pressure in the drain line.

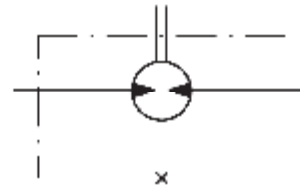

**MH...1 motors with standard shaft seal and without drain connection:**

The shaft seal pressure never exceeds the pressure in the return line.

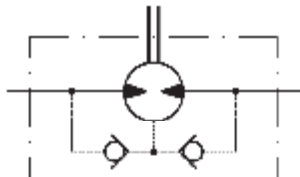

**MH... motors with standard shaft seal and with drain connection:**

The shaft seal pressure equals the pressure in the drain line.

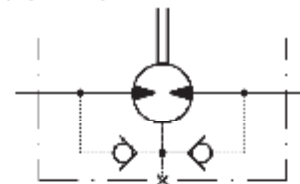

**Max. return pressure without drain line or max. pressure in the drain line**

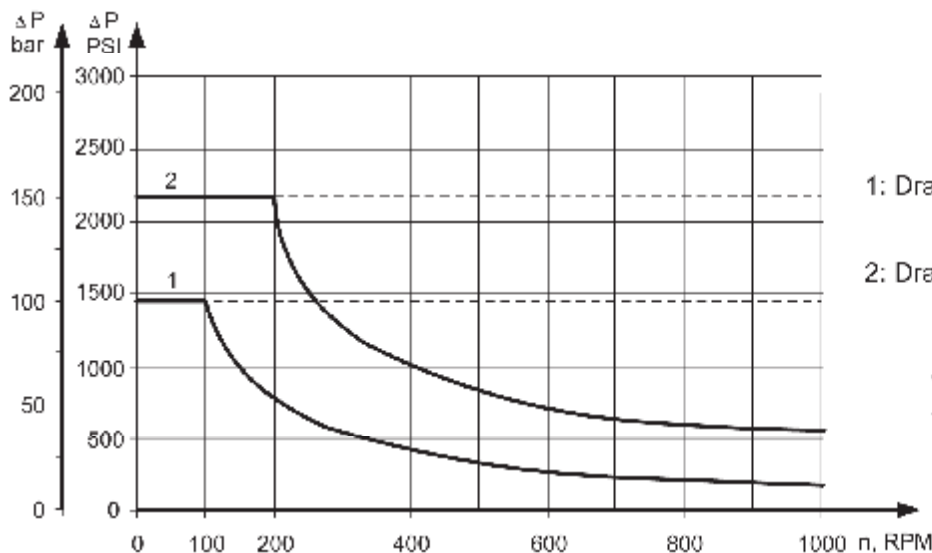

- 1: Drawing for Standard Shaft Seal
- 2: Drawing for High Pressure Seal ("U" Seal)
- - continuous operations
- - - - intermittent operations



**MOTORS WITH TACHO CONNECTION**

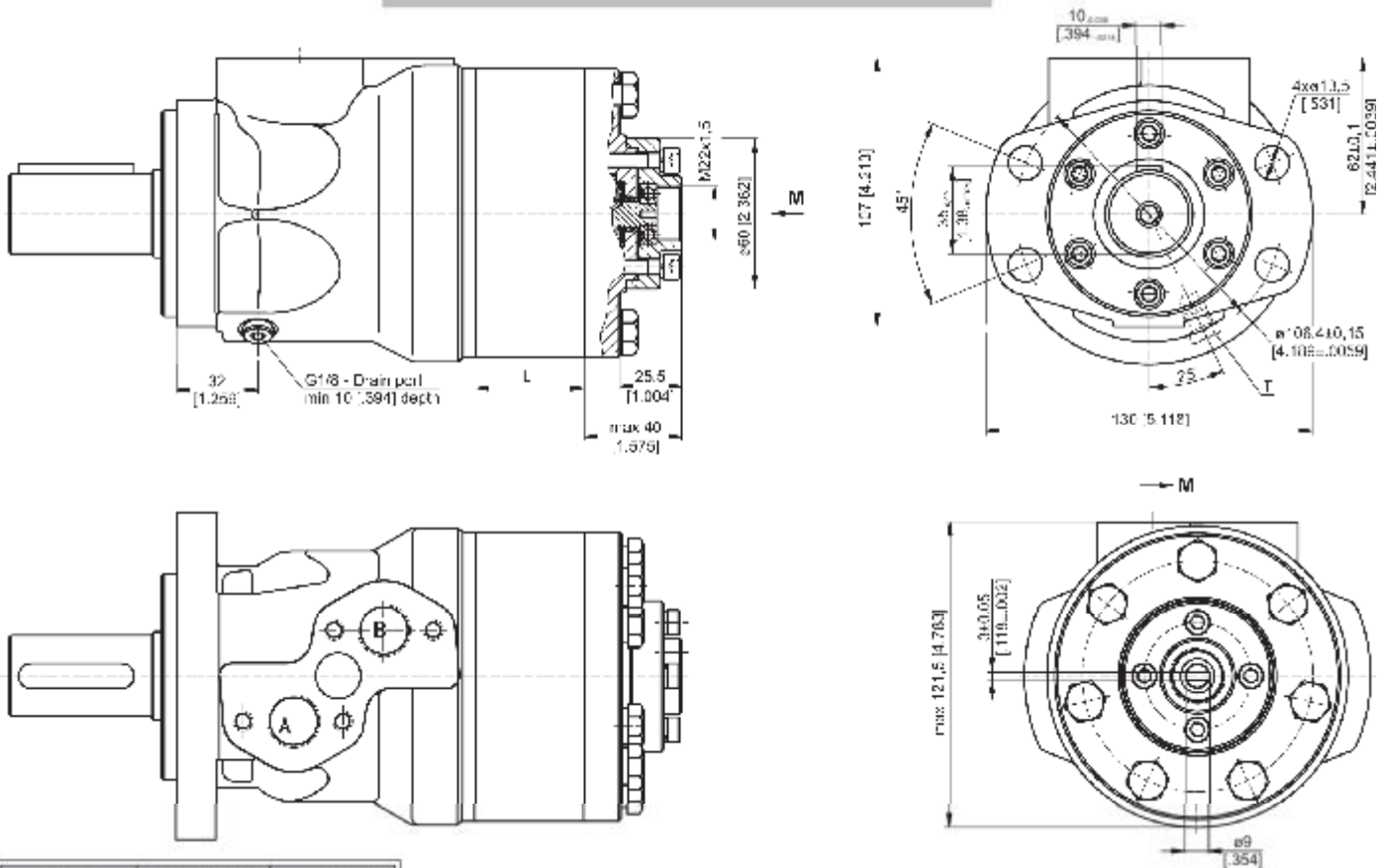

Type	L, mm [in]	L <sub>1</sub> , mm [in]
MH 200	191 [7.52]	27,8 [1.09]
MH 250	198 [7.79]	34,8 [1.37]
MH 315	207 [8.15]	43,5 [1.71]
MH 400	218 [8.58]	54,8 [2.16]
MH 500	233 [9.17]	69,4 [2.73]



**SHAFT EXTENSIONS**

**C** - ø32 straight, Parallel key A10x8x45 DIN 6885  
Max. Torque 77 daNm [6815 lb-in]

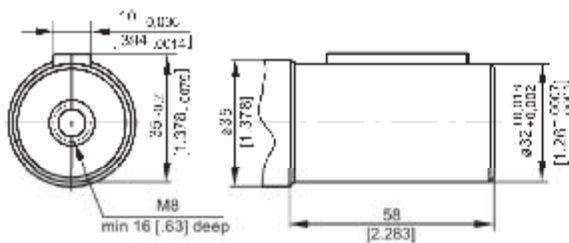

**SH** - ø1¼" splined 14T, DP 12/24 ANSI B92.1-1976  
Max. Torque 95 daNm [8400 lb-in]

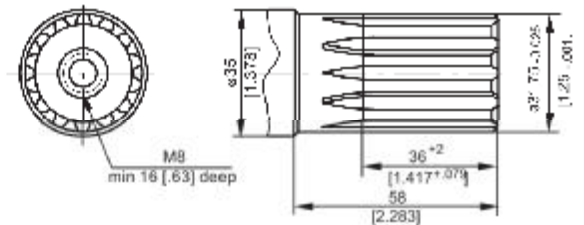

**CB** - ø35 straight, Parallel key A10x8x45 DIN 6885  
Max. Torque 95 daNm [8400 lb-in]

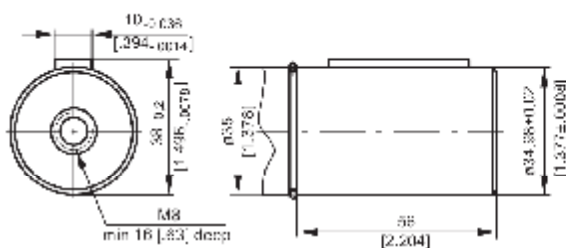

**K** - tapered 1:10, Parallel key B6x6x20 DIN 6885  
Max. Torque 95 daNm [8400 lb-in]

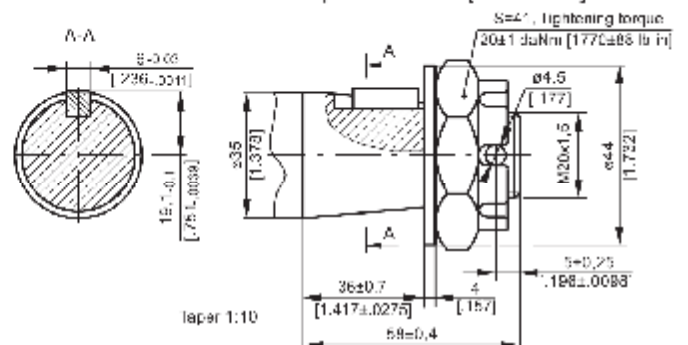





**ORDER CODE**

	1	2	3	4	5	6	7
MH							

**Pos.1 - Displacement code**

<b>200</b>	- 201,3 cm <sup>3</sup> /rev [12.3 in <sup>3</sup> /rev]
<b>250</b>	- 252,0 cm <sup>3</sup> /rev [15.4 in <sup>3</sup> /rev]
<b>315</b>	- 314,9 cm <sup>3</sup> /rev [16.4 in <sup>3</sup> /rev]
<b>400</b>	- 396,8 cm <sup>3</sup> /rev [24.2 in <sup>3</sup> /rev]
<b>500</b>	- 502,4 cm <sup>3</sup> /rev [30.7 in <sup>3</sup> /rev]

**Pos.2 - Shaft Extensions\***

<b>C</b>	- ø32 straight, Parallel key A10x8x45 DIN 6885
<b>SH</b>	- ø1¼" splined 14T ANSI B92.1-1970
<b>CB**</b>	- ø35 straight, Parallel key A10x8x45 DIN 6885
<b>K</b>	- ø35 tapered 1:10, Parallel key B6x6x20 DIN 6885

**Pos.3 - Shaft Seal Version**

omit	- Standard shaft seal
<b>U</b>	- High pressure shaft seal (without check valves)

**Pos.4 - Drain Port**

omit	- with drain port
<b>1</b>	- without drain port

**Pos.5 - Ports**

omit	- BSPP (ISO 228)
<b>M</b>	- Metric (ISO 262)

**Pos.6 - Special Features (see page 120)**

**Pos.7 - Design Series**

omit	- Factory specified
------	---------------------

**NOTES:** \* The permissible output torque for shafts must not be exceeded!  
 \*\* The following combination is not allowed: "CB" shaft with U shaft seal.

The hydraulic motors are mangano-phosphatized as standard.