

CONTENTS:	Page
RH06...1-.../...F..(electrical control)	
-General description.....	1&2
-Ordering code.....	2
-Functional symbols.....	3
-Technical data.....	4
-Dimensions.....	5
-Characteristics.....	6
-Solenoids.....	7
-Accessories.....	8
RH06...2F..(hydraulic control)	
-General description.....	9
-Ordering code.....	9
-Functional symbols.....	9
-Technical data.....	10
-Dimensions.....	10
-Accessories.....	11
RH06...4F..(mechanical control)	
-General description.....	11
-Ordering code.....	11
-Functional symbols.....	12
-Technical data.....	12
-Dimensions.....	12
-Accessories.....	12&13
RH06...6F..(pneumatic control)	
-General description.....	13
-Ordering code.....	13
-Functional symbols.....	13
-Technical data.....	14
-Dimensions.....	14
-Accessories.....	14&15
RH06...7F..(manual control)	
-General description.....	15
-Ordering code.....	15
-Functional symbols.....	15
-Technical data.....	15
-Dimensions.....	16
-Accessories.....	16
RH10...1-.../...F..(electrical control)	
-General description.....	17
-Ordering code.....	18
-Functional symbols.....	18
-Technical data.....	19
-Dimensions.....	20
-Characteristics.....	21
-Solenoids.....	22
-Accessories.....	23&24
RH10...4F..(mechanical control)	
-General description.....	25
-Ordering code.....	27
-Functional symbols.....	28
-Technical data.....	25
-Dimensions.....	26
-Accessories.....	26
RH10...7F..(manual control)	
-General description.....	27
-Ordering code.....	27
-Functional symbols.....	28
-Technical data.....	29
-Dimensions.....	29&30
-Accessories.....	30
Stackable directional control valves (electrical control)	
-General description.....	31,32&33
-Ordering code.....	34
-Functional symbols.....	34
-Technical data.....	34
-Dimensions.....	35,36,37,38,39&40
-Solenoids & accessories.....	41,42,43&44
Stackable control blocks	
-General description.....	45&46
-Ordering code.....	47&48
Automatic switch directional control valve	
-General description.....	49
-Ordering code.....	49
-Technical data.....	50
-Characteristics.....	50

GENERAL DESCRIPTION

- ✓ 4/3- and 4/2- way directional control valves with solenoid operation , heavy duty construction
- ✓ Removable AC and DC voltage coils-quick replacement and rotation in any directions without leakage from the system
- ✓ Wet pin core tubes connect to tank with high pressure capacity
- ✓ Manual override option
- ✓ Maximum control of hydraulic power
- ✓ Reliability and long life
- ✓ Mounting surface CETOP3 ; NG6

RH06...1-...F...

The RH06...1-...F... valves consist of a spool , housing , springs and solenoids.

The directional control valves are designed only for CETOP3 solenoid operation. The valves are used for hydraulic power control. This model is designed with two-spring centered spool about 4/3- and 4/2- valves. RH06...F... is operated by wet solenoids , its housing has 5-chambers and vertical "T" duct.

The operating solenoids are DC type. For AC supply the solenoids are provided with rectifier , which is integrated into the installation ground of the connectors. Standard supply voltage are 12V DC , 24V DC , 110V AC(RAC) and 220V AC(RAC). Electrical connectors conform to DIN 43 650 standard.

The valve location during assembly is of minor importance , but the horizontal position is generally recommended. For functional symbols "08" , "19" , "20" and "82" the horizontal position is obligatory.

At problem with the electric supply an option for manual spool operation is provided.

GENERAL DESCRIPTION

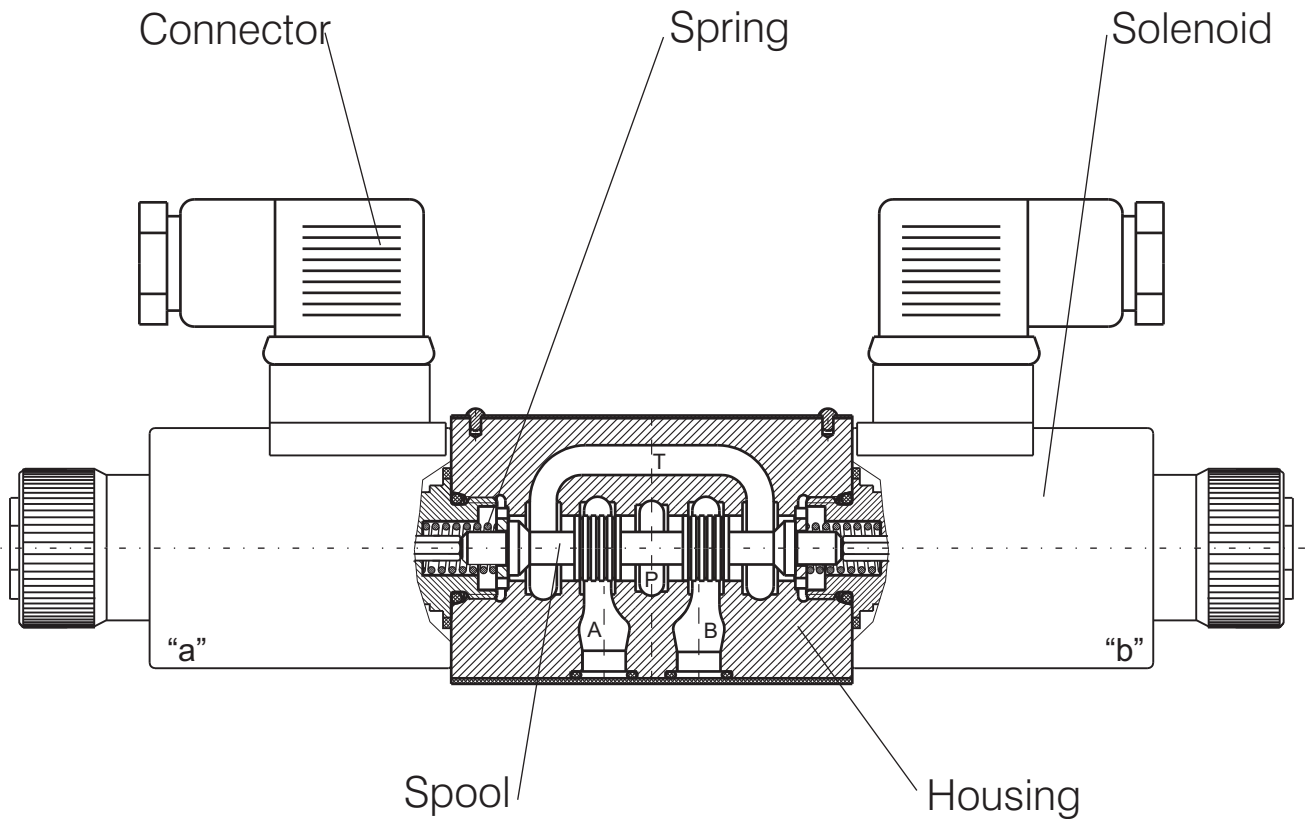

ORDERING CODE

RH 06 1 - .../... F

Directional control valve

Nominal size

Functional symbol
see page 3

Type of control: -electrical

Supply voltage/current frequency
see page 7

Modification

012/00
024/00
110/50
220/50

C1
C2
C3
C4
C5

N
T

Screw cap
Omit -with plastic cap
M-with metal cap
see page 5
Spacers
Omit -without spacers
S-With spacers
see page 5

Backing of the housing
see page 8

Connector

see page 7

FUNCTIONAL SYMBOLS

DESIG-NATION	SYMBOL	INTERMEDIATE	Type of control					DESIG-NATION	SYMBOL	INTERMEDIATE	Type of control				
			1	2	4	6	7				1	2	4	6	7
00			✓	✓		✓	✓	28			✓	✓	✓	✓	✓
01			✓	✓		✓	✓	32			✓	✓	✓	✓	✓
02			✓	✓		✓	✓	33			✓	✓		✓	✓
04			✓	✓		✓	✓	34			✓	✓	✓	✓	✓
05			✓	✓		✓	✓	36			✓	✓	✓	✓	✓
06			✓	✓		✓	✓	39			✓	✓	✓	✓	✓
08			✓	✓		✓		40			✓	✓		✓	✓
10			✓	✓	✓	✓	✓	41			✓	✓		✓	✓
11			✓	✓		✓	✓	42			✓	✓		✓	✓
12			✓	✓	✓	✓	✓	45			✓	✓	✓	✓	✓
13			✓	✓	✓	✓	✓	52			✓	✓		✓	✓
14			✓	✓		✓	✓	61			✓	✓		✓	✓
16			✓	✓	✓	✓	✓	62			✓	✓		✓	✓
17			✓	✓	✓	✓	✓	64			✓	✓	✓	✓	✓
18			✓	✓		✓	✓	68			✓	✓	✓	✓	✓
19*			✓	✓		✓		70			✓	✓	✓	✓	✓
20*			✓	✓		✓		78			✓	✓	✓	✓	✓
21			✓	✓		✓	✓	82*			✓	✓		✓	
24			✓	✓	✓	✓	✓	83			✓	✓	✓	✓	✓
26			✓	✓		✓	✓	98			✓	✓		✓	✓
27			✓	✓	✓	✓	✓	99			✓	✓		✓	✓

* Symbols 19, 20 and 82 are with detent. Both switched positions are alternately fixed and there is no need to energize the solenoid continually. For three positional valves (code 7-manually) the operator is at side "a" except symbols 42, 61 and 62, which operator is at side "b". For two positional valves see the table above. Other symbols on request.

TECHNICAL DATA
GENERAL

DATA	UNIT	VALUE/RANGE
Installation position		optional except symb."08", "19", "20" and "82"-horizontal
Max. ambient temperature	°C	-20...+50
Weight	single solenoid valve double solenoid valve	1.550 2.050

HYDRAULIC

Max. pressure	port P , A & B port T	MPa MPa	32 16
Rated flow	(at Δp 0,1MPa.)	l/min	11...20
Max. flow (depend of symbol-see page 6)		l/min	80
Hydraulic fluid:			
-viscosity		mm ² /s	10...800
-filtration degree		mm	0.025
-temperature		°C	-20...80

ELECTRICAL

Cyclic duration		%	100
Waterproof			IP65
Heat insulation			H
Type of voltage			DC AC
Available voltage /frequency		V/Hz V/Hz	12/00 110/50(60) 24/00 220/50(60)
Voltage tolerance		%	±10
Current consumption	12VDC 24VDC 110V RAC 220V RAC	A	2,6 0,5 1,4 0,25
Max. switching frequencies		cycle/h	15000
Switching time at p=17,5MPa , Q=40l/min and symbol "01"	on off	ms ms	50 25

DIMENSIONS

All dimensions are shown in mm.

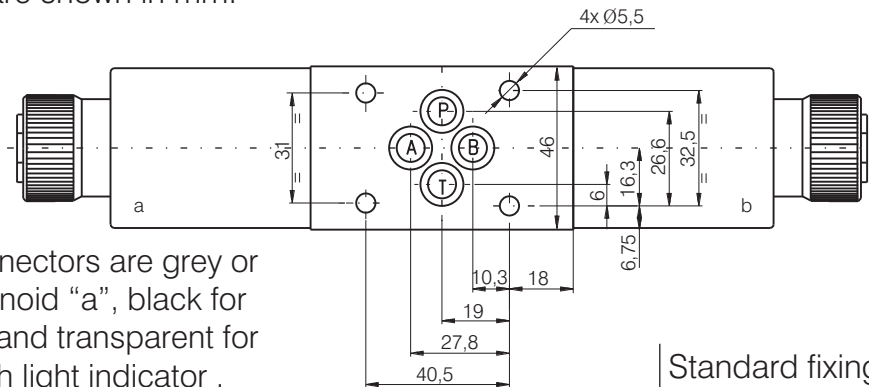

The plug connectors are grey or white for solenoid "a", black for solenoid "b" and transparent for solenoids with light indicator .

For one-lead supply scheme , the metal screw cap should be used-code M see page 2.

Standard fixing bolts are M5x30 (10,9 class recommended). Torque 6...8 Nm. In case of modular mounting spacers are available in order -code S see page 2.

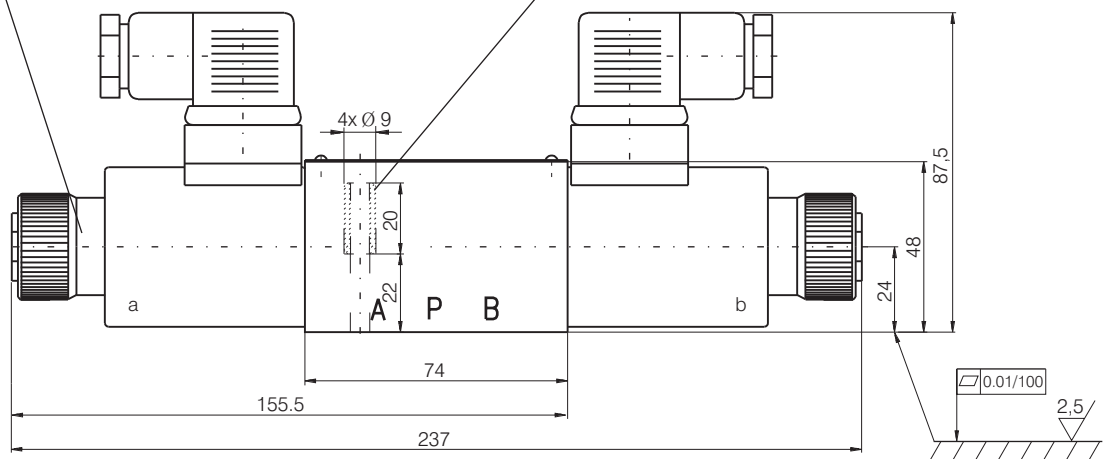

with solenoid "a"
for symbol: 11 , 12 , 14 , 17 , 24 , 27 , 33 , 34 , 39 , 45 , 68 , 70 and 83

with solenoid "b"
for symbols: 10 , 13 , 16 , 28 , 32 , 36 , 64 and 78

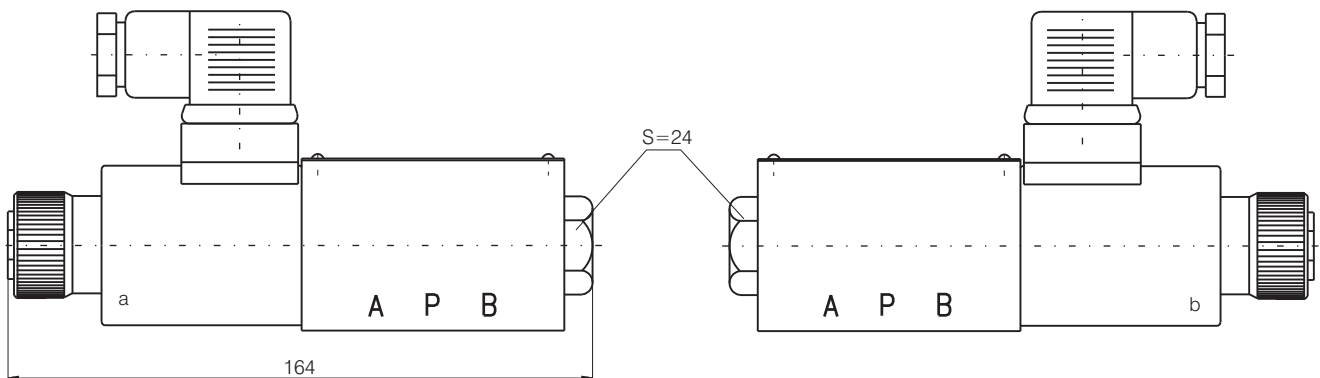

The other dimensions are the same as double solenoid valve.

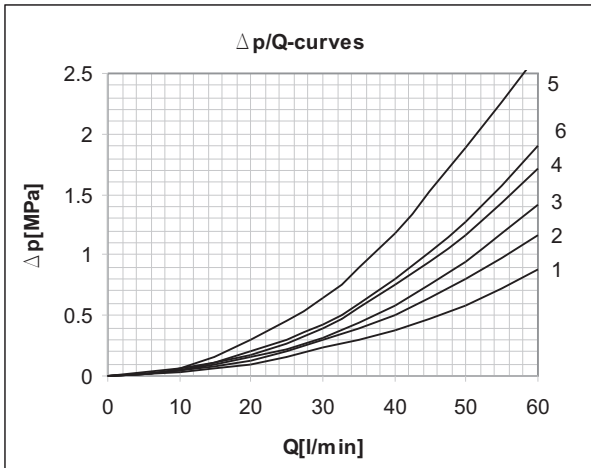
CHARACTERISTICS
 $\Delta p/Q$

SYMBOL	CURVE					SYMBOL	CURVE				
	P>A	P>B	A>T	B>T	P>T		P>A	P>B	A>T	B>T	P>T
00	2	2	1	1	3	28	3			1	
01	2	2	1	1		32	3	3			
02	5	5	5	5	4	33		2	1		3
04	3	3	1	1		34	1				
05	2	2	2	2		36	1	1	2	3	
06	3	3	3	3	4	39	1	1	3	2	
08	2	2	1	1		40		4	6		
10	3	4	3	2		41		4	1		
11	2	2	1	1		42	3	2	1	2	
12	4	3	2	3		45		2	1		
13	2	2				52	1	1			
14	5			5	4	61	4			1	
16	2			1		62	4			6	
17		2	2			64	2			1	
18	2	2	1	1		68	3	3			
19	2	2	2	2		70	3	2	1	2	
20	3	3	2	2		78	1			2	4
21 (mid./end)	2/1	3	3	3		83		2	1		
24		3	1			99	2			2	4
26	3	2	1	2							
27	2			1							

 p/Q

The operating limit of hydraulic power shown here is for applications with two directions of flow (e.g. from P to B and simultaneously from A to T). If the valve is with one direction passage only (e.g. from P to B and with blocked port A), the operating limit may considerably be reduced. The performance limits are measured with hydraulic oil 35 ± 5 cSt, temperature 50°C and supply voltage $0,9U_N$.

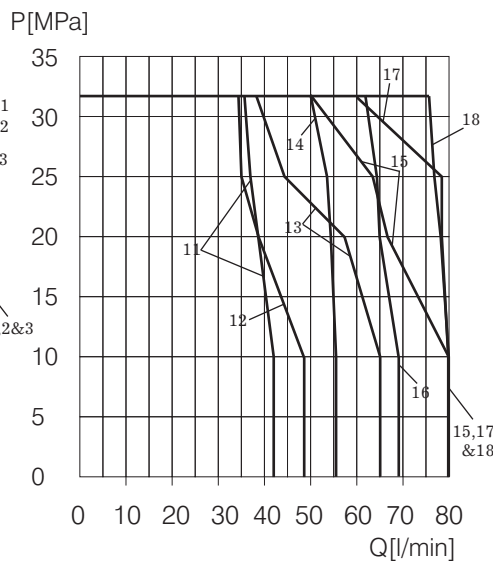
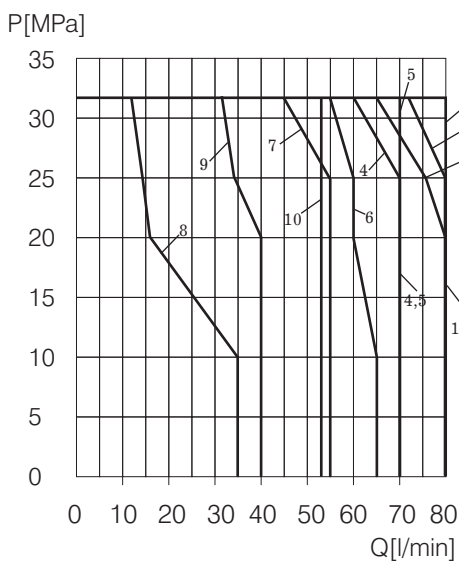

SYMBOL	CURVE	SYMBOL	CURVE
00	1	28	3
01	1	32	8
02	1	33	1
04	3	34	1
05	4	36	9
06	7	39	9
08	5	40	18
10	5	41	17
11	14	42	15
12	5	45	1
13	6	52	12
14	1	61	17
16	1	62	18
17	4	64	1
18	1	68	8
19	16	70	15
20	2	78	11
21	10	82	
24	3	83	1
26	15	98	
27	1	99	13

SOLENOIDS

AC & DC

All dimensions are shown in mm.

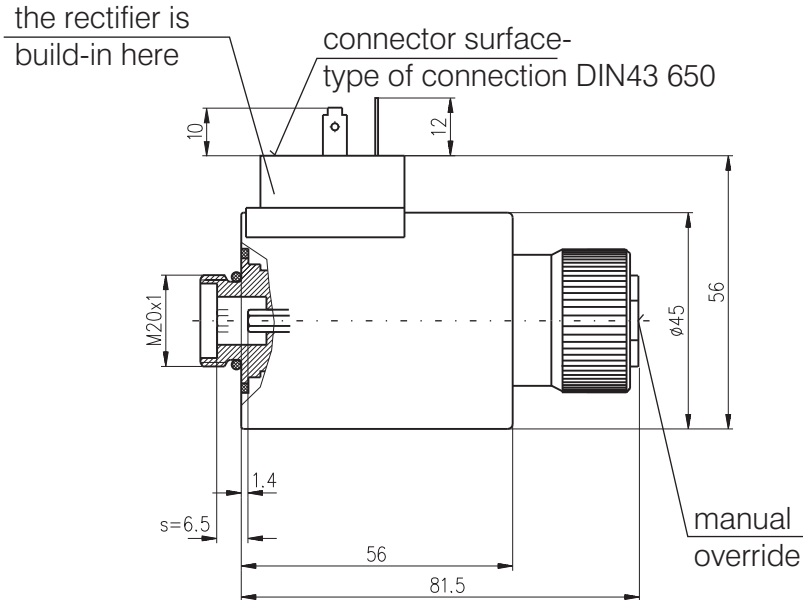

AC and DC solenoids have one and the same dimensions, connections and characteristics. The difference between AC and DC solenoids is in the integrated rectifier into the AC type. The solenoids can be used for 50Hz and 60Hz. The type of rectifier is shown here.

The supply voltages are as follows: 12V DC, 24V DC, 110V AC/50(60)Hz and 220V AC/50(60)Hz. RC filter is integrated into the connector (see below) and is used only with AC solenoids.

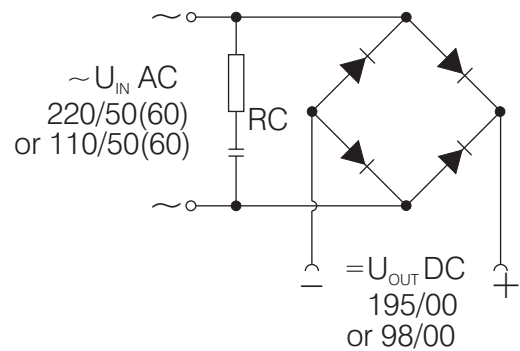

CONNECTORS

		CODE/TYPE		
C1	C2 (for DC type) Pg 11	C3 (for DC type)	C4 (for AC type)	C5 (for AC type)
Without connector				
	With standard connector - DIN 43 650	Connector with light indicator (transparent)	Connector with integrated "RC" filter	Connector with light indicator and "RC" filter (transparent)

ACCESSORIES

SUBPLATES

All dimensions are shown in mm.

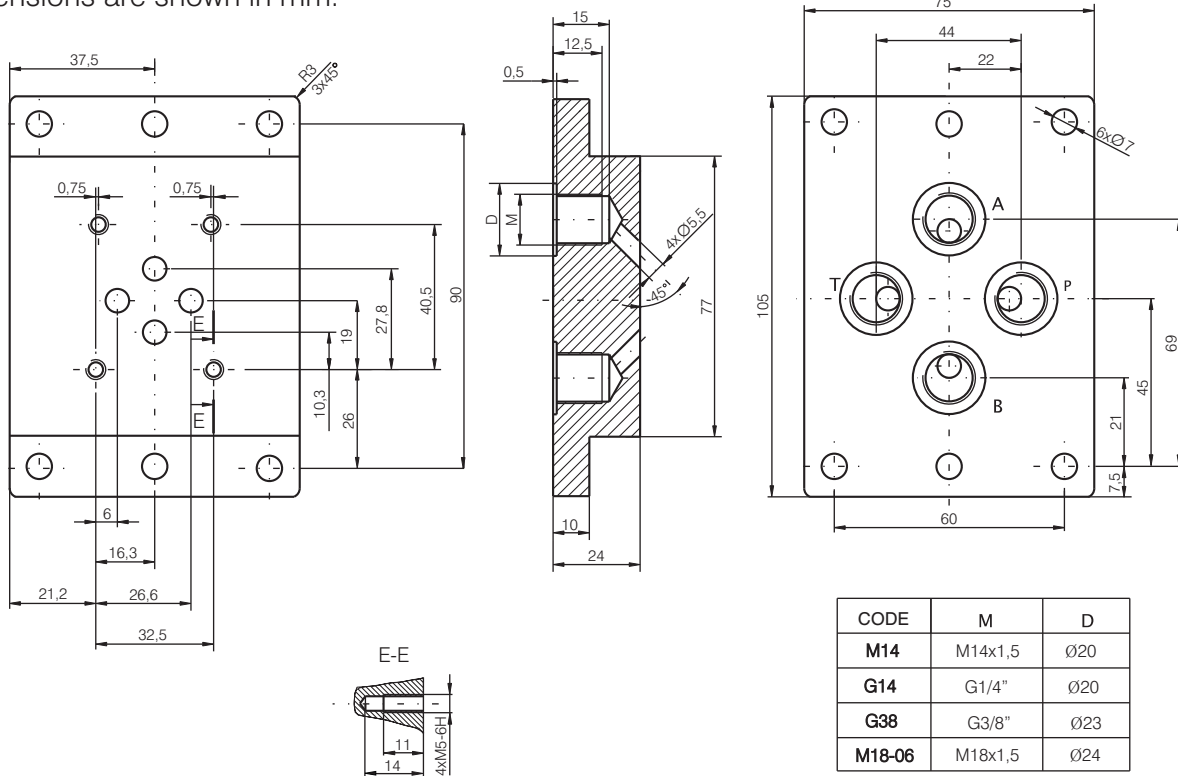

SEALS

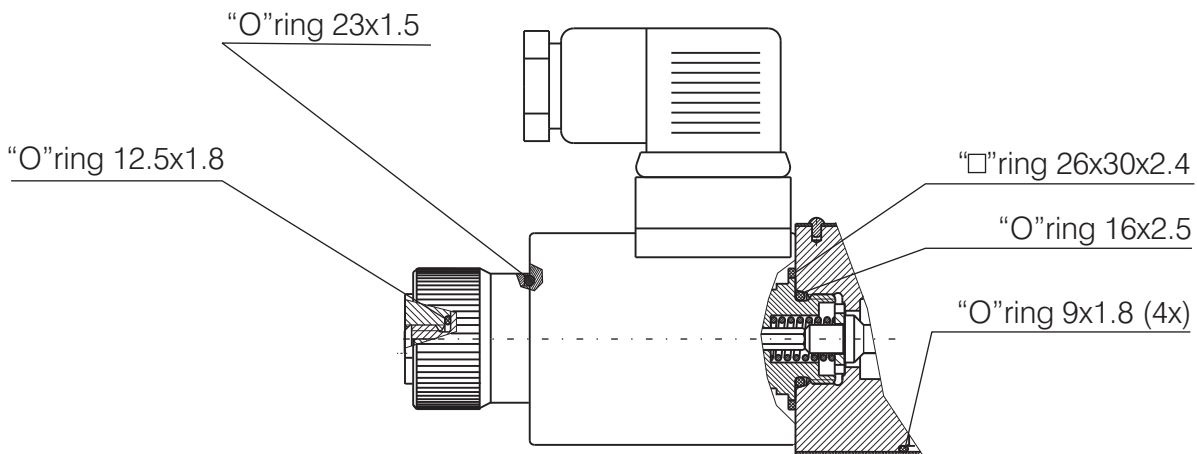

BACKING

We have two options about backing of the housing:
 -code N-about normal realization
 -code T-about tropical realization

SPACERS

See page 5.

GENERAL DESCRIPTION

- ✓ 4/3- and 4/2- way directional control valves with hydraulic operation
- ✓ Reliability and long life
- ✓ Mounting surface CETOP3 ; NG6

RH06...2F...

The RH06...2F... valves consist of a spool , housing , springs and hydraulic control. The valves are used for hydraulic power control. This model is designed with two-spring centered spool about 4/3- and 4/2- valves. The housing has 5-chambers and a vertical "T" duct.

The valve location during assembly is of minor importance , but the horizontal position is generally recommended. For functional symbols "08" , "19" , "20" and "82" , the horizontal position is obligatory.

ORDERING CODE

RH		06				F			
Directional control valve									
Nominal size									
Functional symbol	see page 3								
Type of control	hydraulic	- 2							
	mechanical	- 4							
	pneumatic	- 6							
	manual	- 7							

Spacers
Omit -Without spacers
S -with spacers see page 5

N Backing of the housing
T see page 8

Omit -without detent
D -with detent Detent*

Modification

* Only for type of control-7

FUNCTIONAL SYMBOLS

See page 3.

TECHNICAL DATA

DATA	UNIT	VALUE/RANGE
Weight -three positional -two positional	kg	2,2 1,6
Max. Pressure port P , A & B port T	MPa	32 16
Rated flow (at $\Delta p=0,1$ MPa.)	l/min	11...20
Pilot pressure -P _{min} -P _{max}	MPa	1...1,5+P _T 21

DIMENSIONS

All dimensions are shown in mm. The other dimensions and requirements are as at RH06...1...F-see page 5.

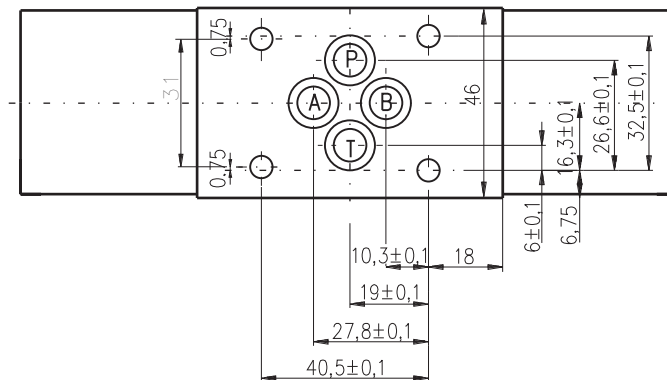

Symbols 00 , 01 , 02 , 04 , 05 , 06 , 08 , 18 , 19 , 20 , 21 , 26 , 40 , 41 , 42 , 52 , 61 , 62 , 82 , 98 , 99

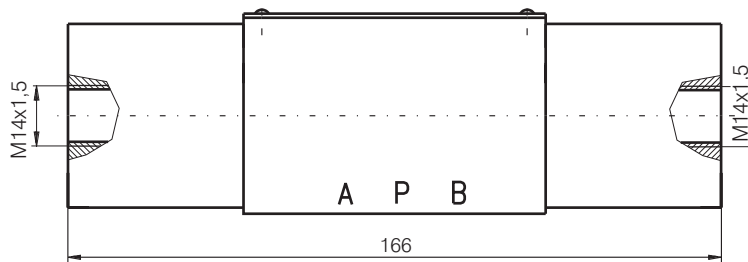

Symbols 11 , 12 , 14 , 17 , 24 , 27 , 33 ,
34 , 39 , 45 , 68 , 70 , 83

Symbols 10 , 13 , 16 , 28 , 32 , 36 , 64 , 78

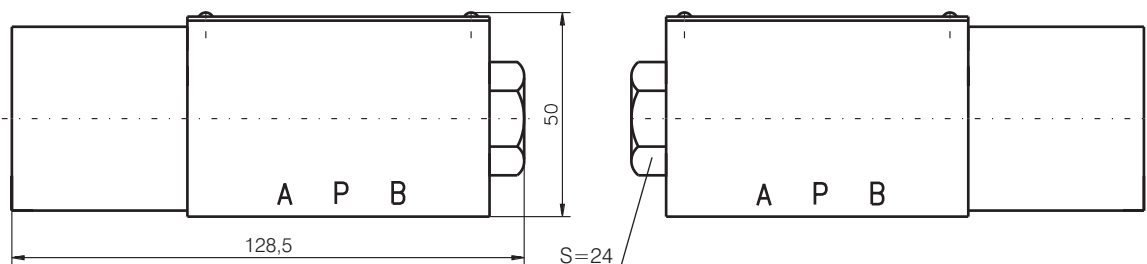

ACCESSORIES

SUBPLATES

Subplate is as at RH06...F... see page 8.

SEALS

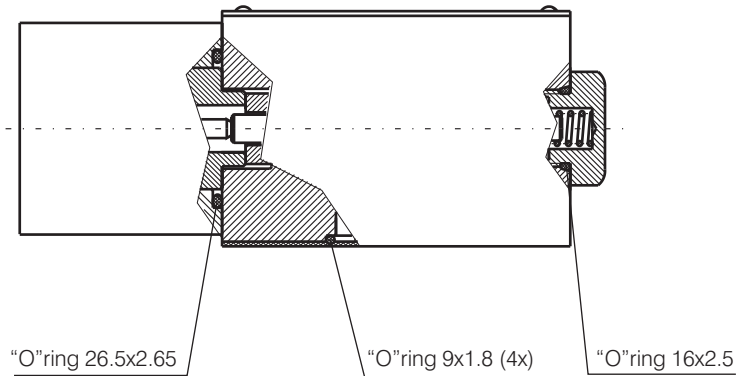

BACKING

Backing of the housing is as at RH06...1-...F... see page 8.

SPACERS

Spacers is as at RH06...1-...F... see page 5.

DIRECTIONAL CONTROL VALVES-CETOP 3

RH06...4F...

GENERAL DESCRIPTION

- ✓ 4/3- and 4/2- way directional control valves with mechanical operation
- ✓ Reliability and long life
- ✓ Mounting surface CETOP3 ; NG6

RH06...4F...

These RH06...4F... valves consist of a spool , housing , springs and mechanical control. The valves are used for hydraulic power control. This model is designed with two-spring centered spool. The housing has 5-chambers and vertical "T" duct.

The valve location during assembly is of minor importance , but the horizontal position is generally recommended.

ORDERING CODE

See page 9.

FUNCTIONAL SYMBOLS

See page 3.

TECHNICAL DATA

DATA		UNIT	VALUE/RANGE
Weight		kg	1,420
Max. Pressure	port P , A & B port T	MPa	32 16
Rated flow	(at $\Delta p=0,1\text{MPa.}$)	l/min	11...20
Actuating force	$-F_{\min}$ $-F_{\max}$	N	30 130

DIMENSIONS

All dimensions are shown in mm. The other dimensions and requirements are as RH06...1...F-see page 5.

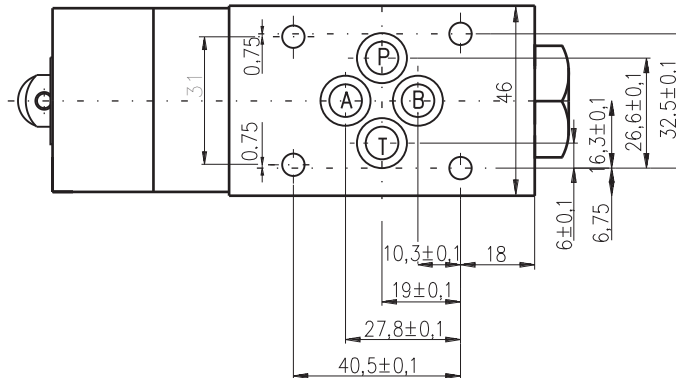

Symbols 12 , 17 , 24 , 27 , 34 , 39 , 45 , 68 , 70 , 83

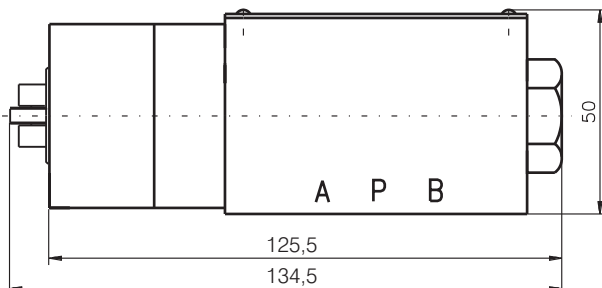

Symbols 10 , 13 , 16 , 28 , 32 , 36 , 64 , 78

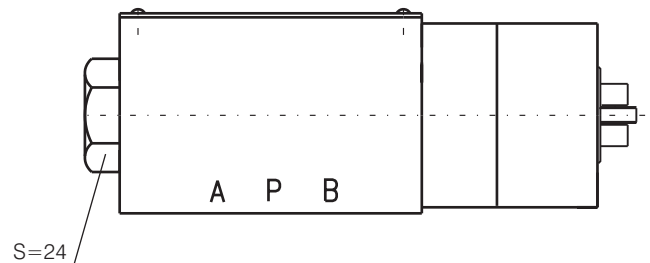
ACCESSORIES
SUBPLATES

Subplate is as at RH06...1-...F... see page 8.

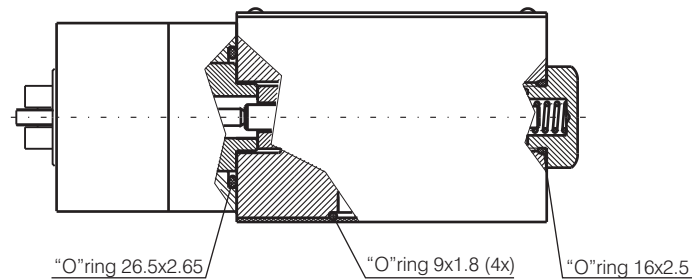
SEALS

BACKING

Backing of the housing is as at RH06...1-...F... see page 8.

SPACERS

Spacers is as at RH06...1-...F... see page 5.

DIRECTIONAL CONTROL VALVES-CETOP 3
GENERAL DESCRIPTION

- ✓ 4/3- and 4/2- way directional control valves with pneumatic operation
- ✓ Reliability and long life
- ✓ Mounting surface CETOP3 ; NG6

RH06...6F...

The RH06...6F... valves consist of a spool , housing , springs and pneumatic control. The valves are used for hydraulic power control. This model is designed with two-spring centered spool about 4/3- and 4/2- valves. The housing has 5-chambers and vertical "T" duct.

The valve location during assembly is of minor importance , but the horizontal position is generally recommended. For functional symbols "08" , "19" , "20" and "82" , the horizontal position is obligatory.

ORDERING CODE

See page 9.

FUNCTIONAL SYMBOLS

See page 3.

TECHNICAL DATA

DATA	UNIT	VALUE/RANGE
Weight -three positional -two positional	kg	1,950 1,450
Max. Pressure port P , A & B port T	MPa	32 16
Rated flow (at $\Delta p=0,1\text{MPa}$)	l/min	11...20
Pilot pressure -P _{min} -P _{max}	MPa	0,2 1

DIMENSIONS

All dimensions are shown in mm. The other dimensions and requirements are as RH06...1...F-see page 5.

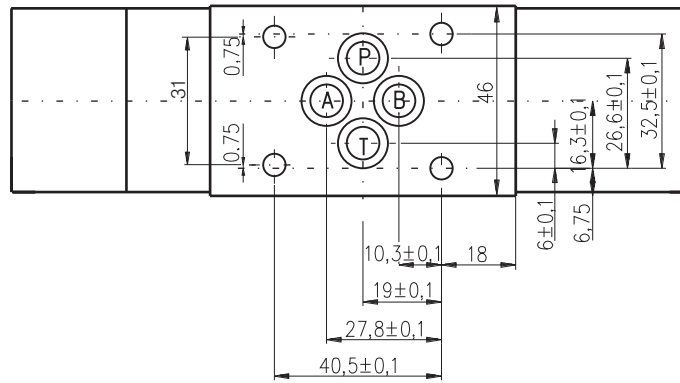

Symbols 00 , 01 , 02 , 04 , 05 , 06 , 08 , 18 , 19 , 20 , 21 , 26 , 40 , 41 , 42 , 52 , 61 , 62 , 82 , 98 , 99

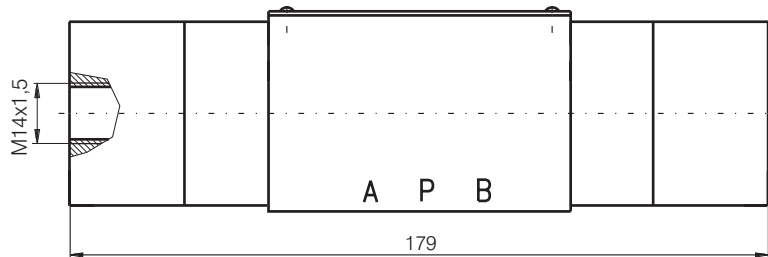

Symbols 11 , 12 , 14 , 17 , 24 , 27 , 33 ,
34 , 39 , 45 , 68 , 70 , 83

Symbols 10 , 13 , 16 , 28 , 32 , 36 , 64 , 78

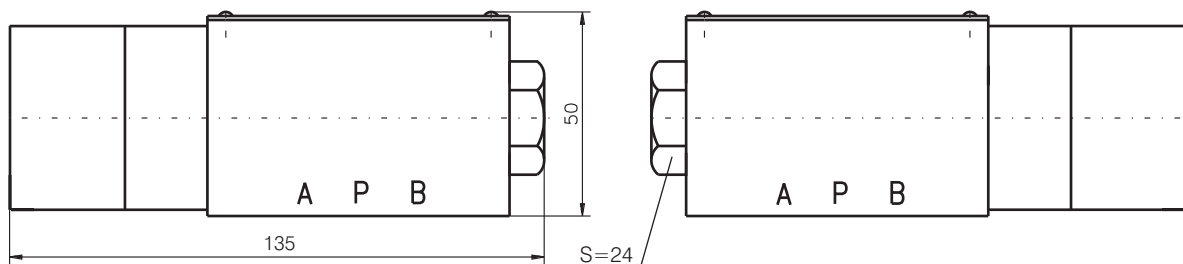

ACCESSORIES

SUBPLATES

Subplate is as at RH06...1...F... see page 8.

SEALS

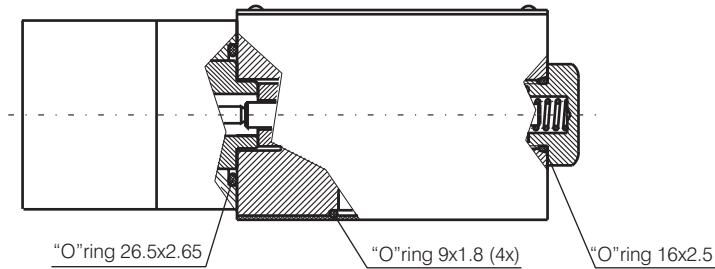

BACKING & SPACERS

Backing of the housing and spacers is as at RH06...1-...F... see page 8 & 5.

DIRECTIONAL CONTROL VALVES-CETOP 3

GENERAL DESCRIPTION

- ✓ 4/3- and 4/2- way directional control valves with manual operation
- ✓ Reliability and long life
- ✓ Mounting surface CETOP3 ; NG6

RH06...7F...

The RH06...7F... valves consist of a spool , housing , springs and manual control.

The valves are used for hydraulic power control. This model is designed with two-spring centered spool about 4/3- and 4/2- valves. The housing has 5-chambers and vertical "T" duct. There are two possible versions of valve - with detent and without detent.

The valve location during assembly is of minor importance , but the horizontal position is generally recommended.

ORDERING CODE

See page 9.

FUNCTIONAL SYMBOLS

See page 3.

TECHNICAL DATA

DATA	UNIT	VALUE/RANGE
Weight	kg	2,2
Max. pressure port P , A & B port T	MPa	32 16
Rated flow (at $\Delta p=0,1\text{MPa}$)	l/min	11...20
Angular movement	°	± 32
Actuating force	N	30

DIMENSIONS

All dimensions are shown in mm. The other dimensions and requirements are as RH06...1...F-see page 5.

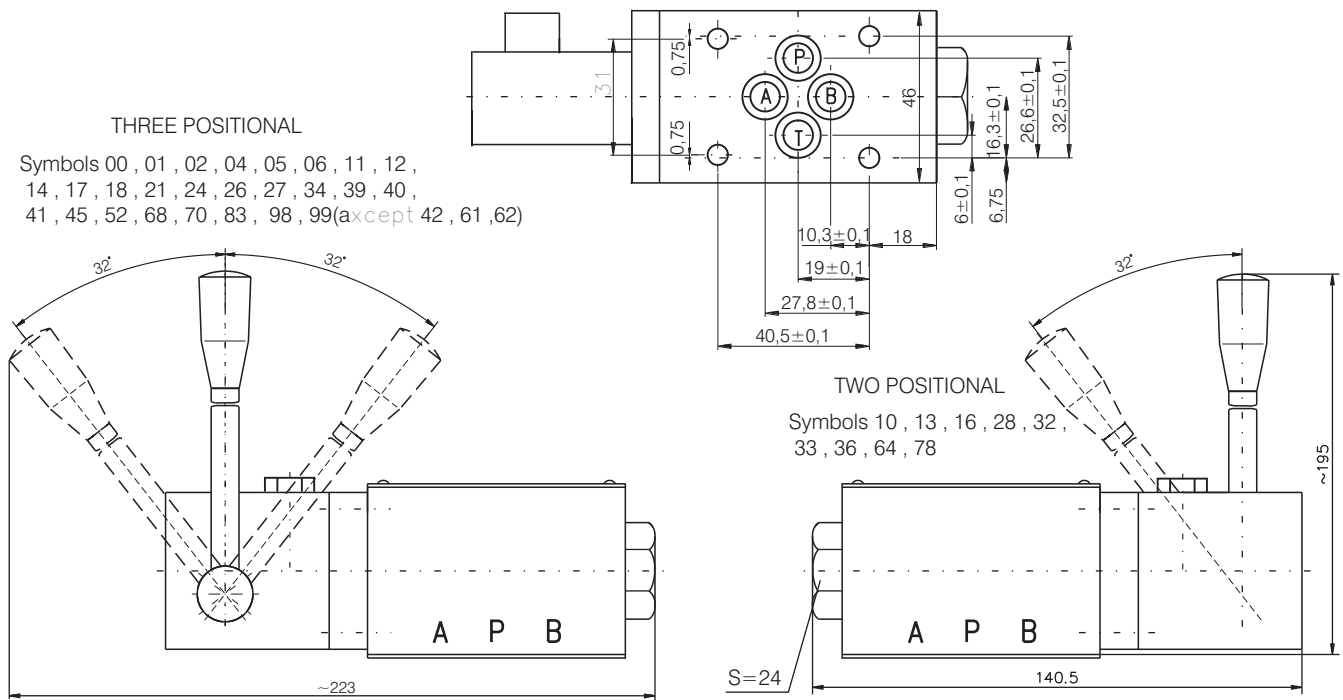

For three positional valves symbols 42 , 61 and 62 the operator is at side "b".

ACCESSORIES

SUBPLATES

Subplate is as at RH06...1-...F... see page 8.

SEALS

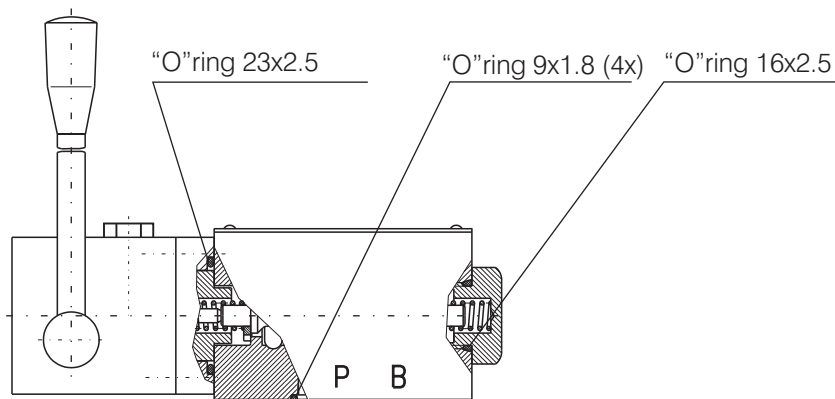

BACKING

Backing of the housing is as at RH06...1-...F... see page 8.

SPACERS

Spacers is as at RH06...1-...F... see page 5.

GENERAL DESCRIPTION

- ✓ 4/3- and 4/2- way directional control valves with solenoid operation , heavy duty construction
- ✓ Removable AC and DC voltage coils-quick replacement and rotation in any directions without leakage from the system
- ✓ Wet pin core tubes connect to tank with high pressure capacity
- ✓ Manual override option
- ✓ Maximum control of hydraulic power
- ✓ Reliability and long life
- ✓ Mounting surface CETOP5 ; NG10

RH10...1-...F...

The RH10...1...-...F... valves consist of a spool , housing , springs and solenoids.

The valves are used for hydraulic power control. This model is designed with two-spring centered spool about 4/3- and 4/2- valves. RH10...1...-...F... is operated by wet solenoids , its housing has 5-chambers and vertical "T" duct.

The operating solenoids are DC type. For AC supply the solenoids are provided with rectifier , which is integrated into the installation ground of the connectors. Standard supply voltage are 12V DC , 24V DC , 110V AC(RAC) and 220V AC(RAC). Electrical connectors conform to DIN 43 650 standard.

The valve location during assembly is of minor importance , but the horizontal position is generally recommended. For functional symbols "08"and "20" the horizontal position is obligatory.

At problem with the electric supply an option for manual spool operation is provided.

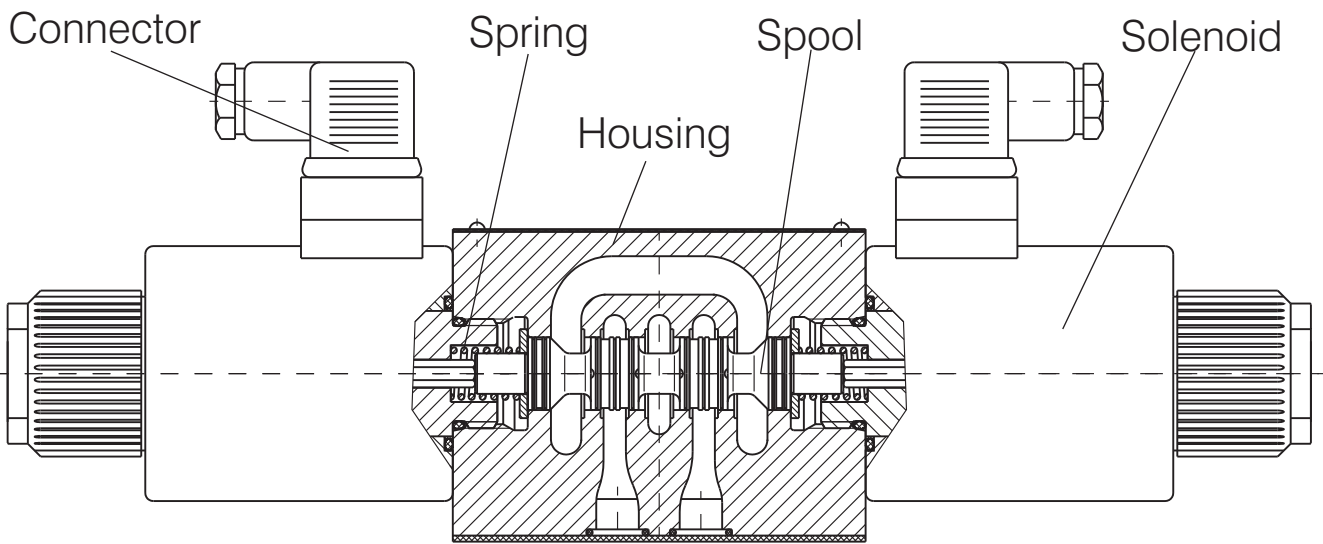

ORDERING CODE

RH	10		1	-	.../...	F				
----	----	--	---	---	---------	---	--	--	--	--

Directional control valve

Nominal size

Functional symbol

see page 18

Type of control-electrical

 012/00
 024/00
 110/50
 220/50

 Supply voltage/current frequency
 see page 22

Modification

Switching time speed control of spool

Omit -without throttle
R1- with fixed throttle
R2- with adj. throttle
 see page 20

 Screw cap
Omit-with plastic cap
M-with metal cap
 see page 20

N Backing of the housing
T see page 24

Connectors

C1
C2
C3
C4
C5

see page 7

FUNCTIONAL SYMBOLS

DESIG-NATION	SYMBOL	INTERMEDIATE	DESIG-NATION	SYMBOL	INTERMEDIATE	DESIG-NATION	SYMBOL	INTERMEDIATE
00			16			39		
01			17			40		
02			18			41		
04			20*			42		
05			21			45		
06			24			61		
08			26			62		
10			27			64		
11			28			68		
12			32			70		
13			33			83		
14			36			20*-with detent		

TECHNICAL DATA
GENERAL

DATA	UNIT	VALUE/RANGE
Installation position		optional except symb."08"and "20"-horizontal
Max. ambient temperature	°C	-20...+50
Weight	single solenoid valve double solenoid valve	5 6,6

HYDRAULIC

Max. pressure	port P , A & B port T	MPa MPa	32 16
Rated flow	(at Δp 0,1MPa.)	l/min	15...45
Max. flow (depend of symbol-see page 21)		l/min	140
Hydraulic fluid:			
-viscosity		mm ² /s	10...800
-filtration degree		mm	0.025
-temperature		°C	-20...80

ELECTRICAL

Cyclic duration		%	100
Waterproof			IP65
Heat insulation			H
Type of voltage			DC AC
Available voltage /frequency		V/Hz V/Hz	12/00 110/50(60) 24/00 220/50(60)
Voltage tolerance		%	±10
Current consumption	12VDC 24VDC 110V RAC 220V RAC	A	2,9 0,5 1,6 0,25
Max. switching frequencies		cycle/h	15000
Switching time at p= 15MPa , Q=63,5l/min and symbol "01"	on off	ms ms	94 32

DIMENSIONS

All dimensions are shown in mm.

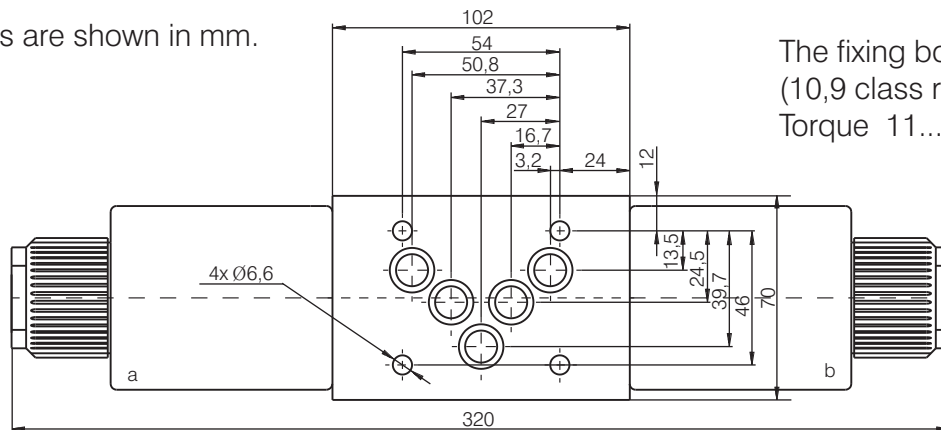

The fixing bolts are M6x40 (10,9 class recommended). Torque 11...14 Nm.

The plug connectors are grey or white for solenoid "a", black for solenoid "b" and transparent for solenoids with light indicator .

For one-lead supply scheme , the metal screw cap should be used-code M see page 18.

Variant with adjustable throttle for switching over speed control (see page18).
With fixed throttle Ø0,6mm.-code R1 , with adjustable throttle-R2(internal hexagon S=3).

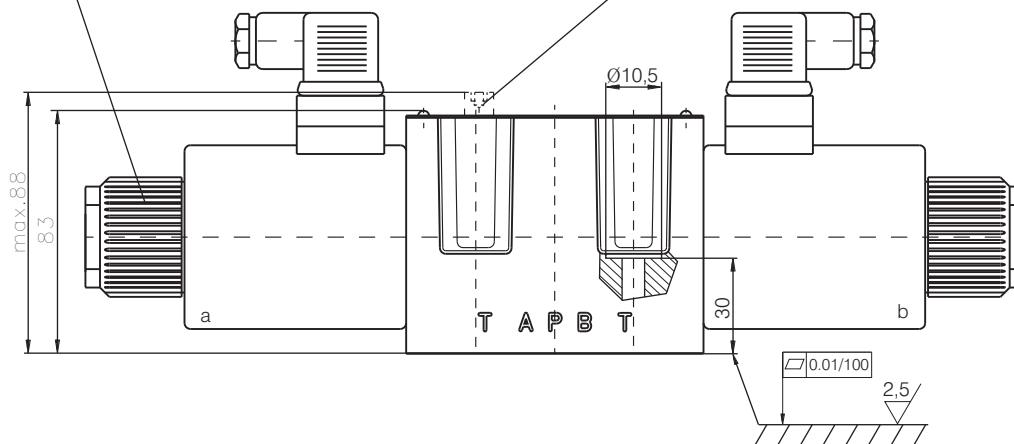

with solenoid "a"
for symbol: 11 , 12 , 14 , 17 , 24 , 27 , 33 , 34 , 39 , 45 , 68 , 70 and 83

with solenoid "b"
for symbols: 10 , 13 , 16 , 28 , 32 , 36 , 64 and 78

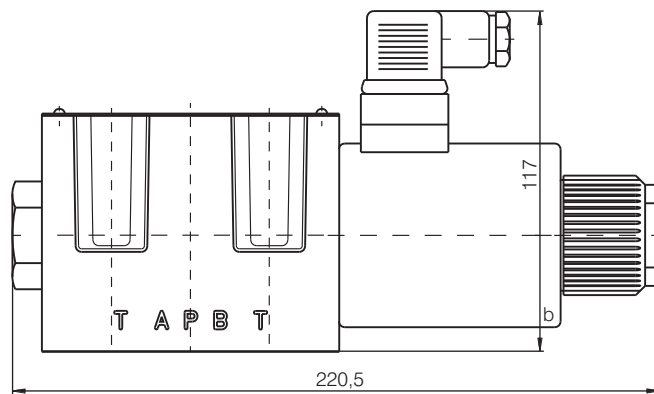
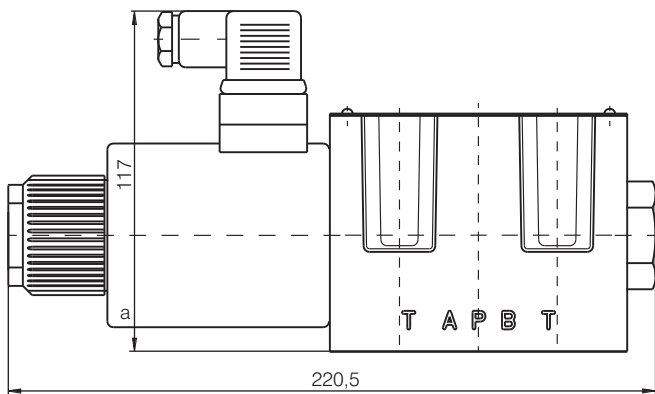

The other dimensions are the same as double solenoid valve.

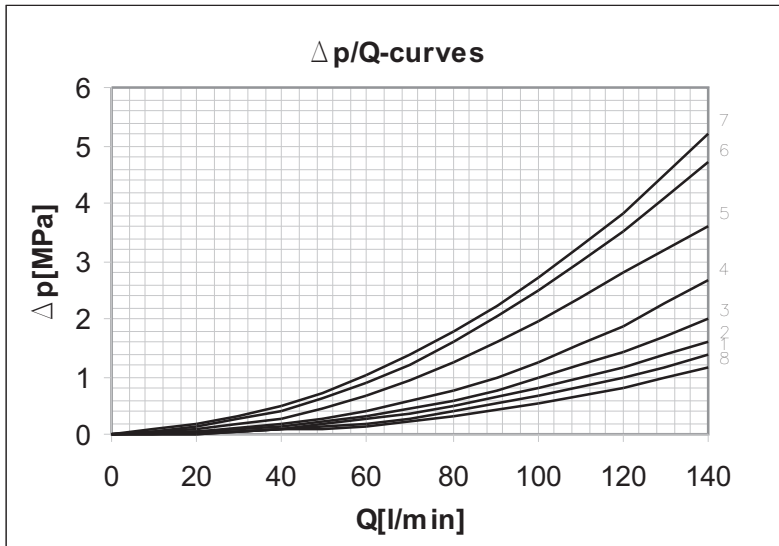
CHARACTERISTICS
 $\Delta p/Q$

SYMBOL	CURVE				
	P>A	P>B	A>T	B>T	P>T
00	3	3	8	8	4
01	3	3	1	1	
02	6	6	5	5	4
04	3	3	2	2	
05	1	1	1	8	
06	2	2	7	5	2
08	2	2	1	1	
10	2	2	1	1	
11	2	2	1	1	
12	2	2	1	1	
13	2	2			
14	6			5	4
16	2			1	
17		1	1		
18	2	2	1	1	
20	3	3	2	2	
21	2	2	1	1	
24	3	3	2	2	
26	3	3	2	1	
27	3			1	
28	3	3	2	2	
32	4	4			
33		3	8		4
36	4	4	2	2	
39	4	4	2	2	
40		4	1		
41		4	8		
42	3	3	2	1	
45		2	1		
61	4			8	
62	4			1	
64	2			1	
68	4	4			
70	3	3	2	1	
83		2	1		

 p/Q

The operating limit of hydraulic power shown here is for applications with two directions of flow (e.g. from P to B and simultaneously from A to T). If the valve is with one direction passage only (e.g. from P to B and with blocked port A), the operating limit may considerably be reduced. The performance limits are measured with hydraulic oil 35 ± 5 cSt, temperature 50°C and supply voltage $0,9U_N$.

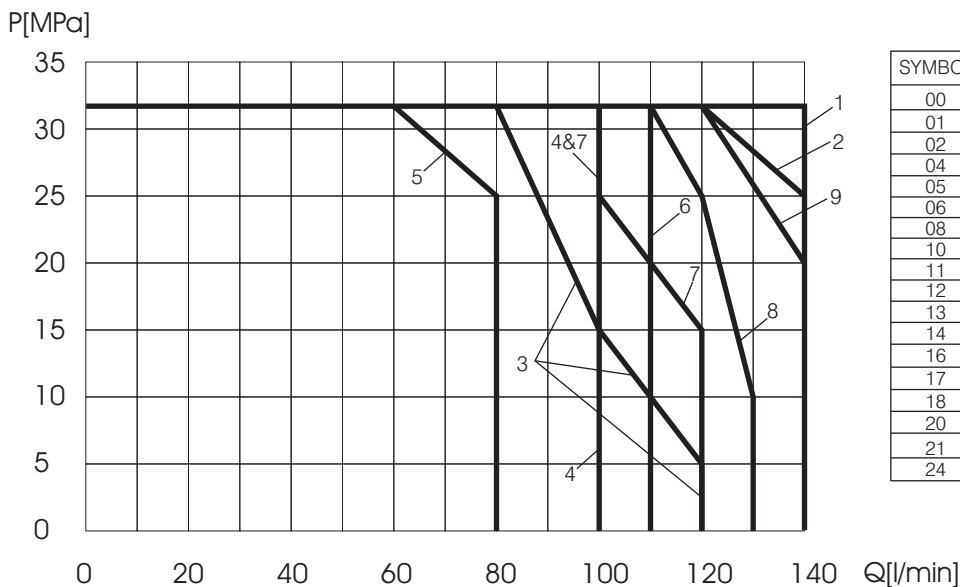

SYMBOL	CURVE	SYMBOL	CURVE
00	1	26	8
01	2	27	1
02	2	28	9
04	9	32	3
05	1	33	1
06	2	36	5
08	2	39	5
10	1	40	6
11	1	41	7
12	1	42	8
13	2	45	2
14	2	61	7
16	2	62	6
17	1	64	2
18	2	68	3
20	2	70	8
21	4	83	2
24	9		

All dimensions are shown in mm.

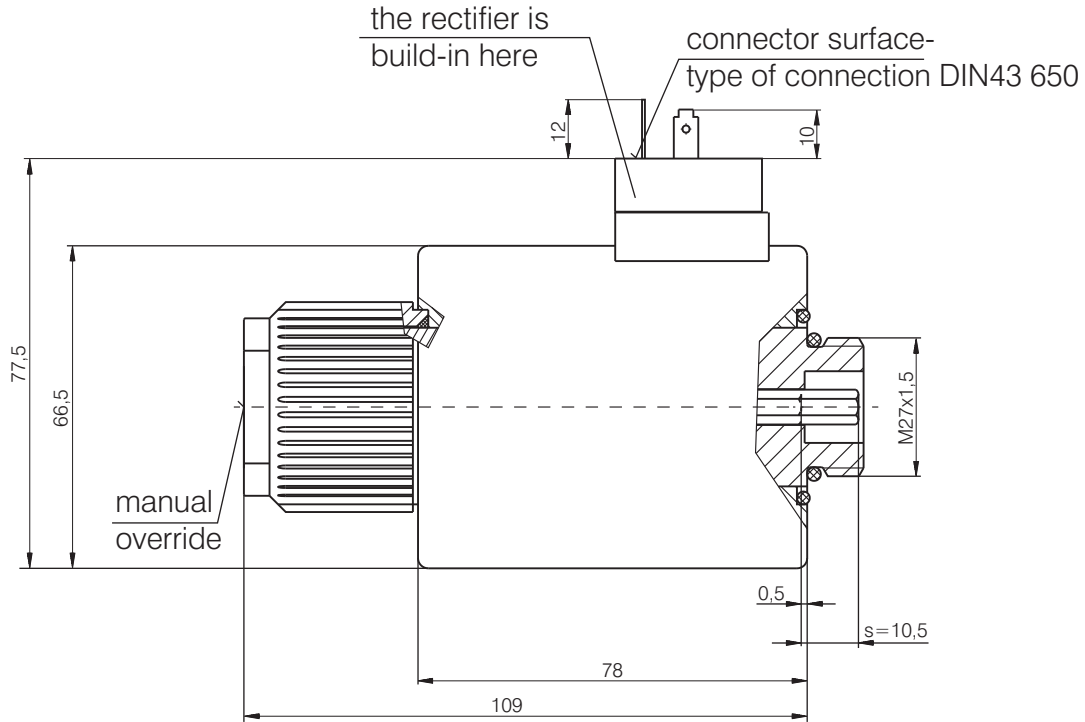

AC and DC solenoids have one and the same dimensions, connections and characteristics. The difference between AC and DC solenoids is in the integrated rectifier into the AC type. The solenoids can be used for 50Hz and 60Hz. The type of rectifier is shown here.

The supply voltages are as follows: 12V DC, 24V DC, 110V AC/50(60)Hz and 220V AC/50(60)Hz. RC filter is integrated into the connector (see below) and is used only with AC solenoids.

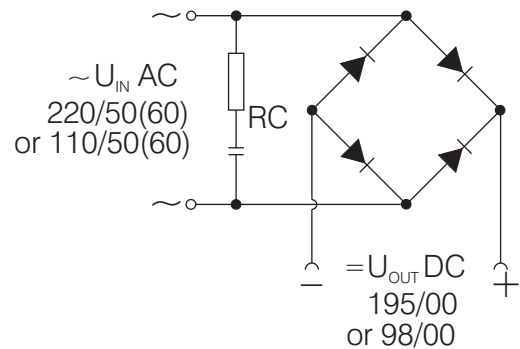

See page 7

All dimensions are shown in mm.

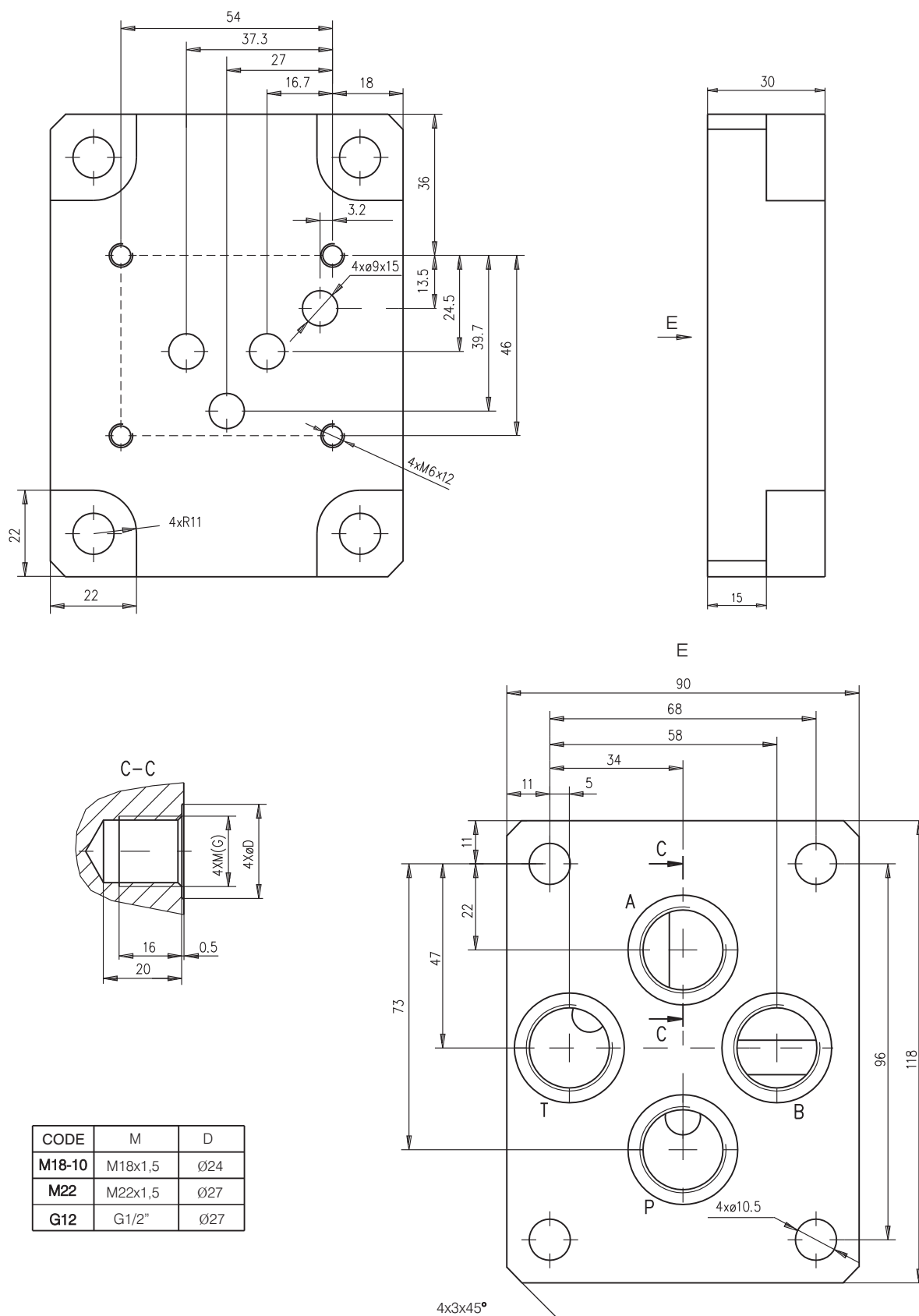

CODE	M	D
M18-10	M18x1,5	Ø24
M22	M22x1,5	Ø27
G12	G1/2"	Ø27

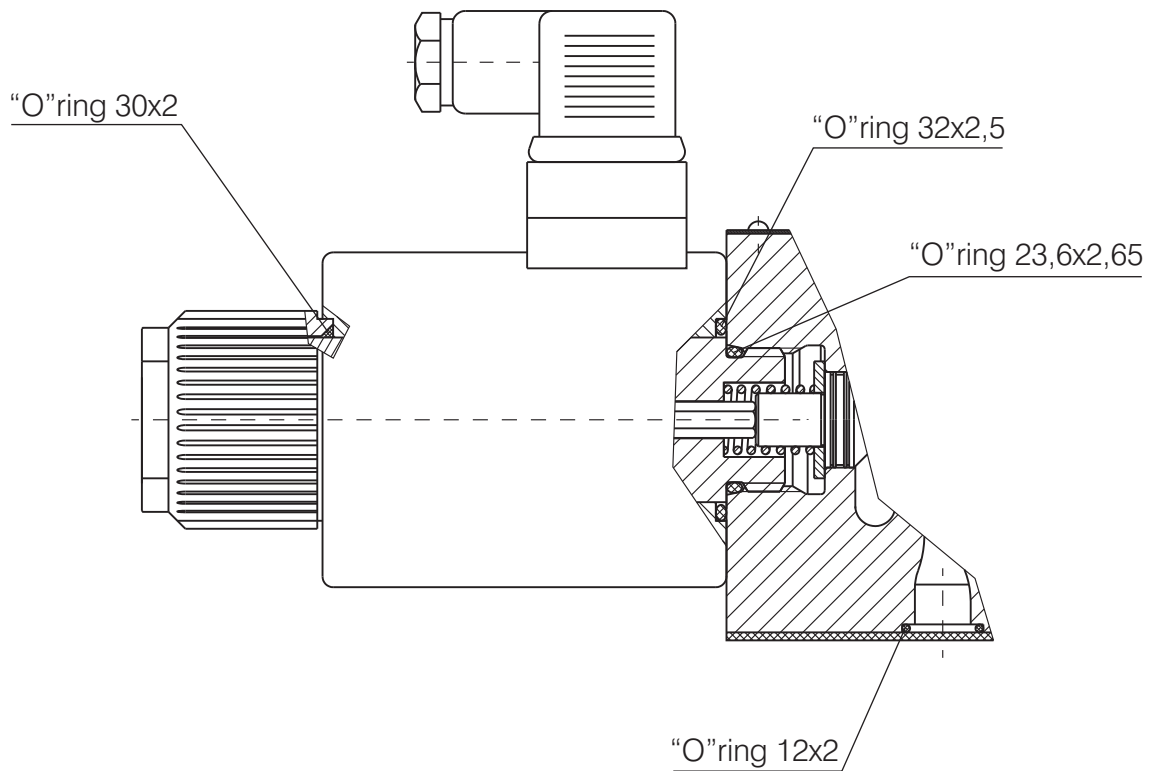

BACKING

We have two options about backing of the housing:

- code N-about normal realization
- code T-about tropical realization

GENERAL DESCRIPTION

- ✓ 4/2- way directional control valves with mechanical operation
- ✓ Reliability and long life
- ✓ Mounting surface CETOP5 ; NG10

RH10...4F...

The RH10...4F... valves consist of a spool , housing , springs and mechanical control. The valves are used for hydraulic power control. This model is designed with two-spring centered spool. The housing has 5-chambers and vertical "T" duct. There are two possible versions of valve - with detent and without detent. The valve location during assembly is of minor importance , but the horizontal position is generally recommended.

ORDERING CODE

see page 27

FUNCTIONAL SYMBOLS

see page 28

TECHNICAL DATA

DATA	UNIT	VALUE/RANGE
Weight	kg	4
Max. Pressure port P , A & B port T	MPa	32 16
Rated flow (at $\Delta p=0,1\text{MPa.}$)	l/min	15...45
Actuating force $-F_{\min}$ $-F_{\max}$	N	50 150

DIMENSION

All dimensions are shown in mm. The other dimensions and requirements are as RH10...1...F-see page 20.

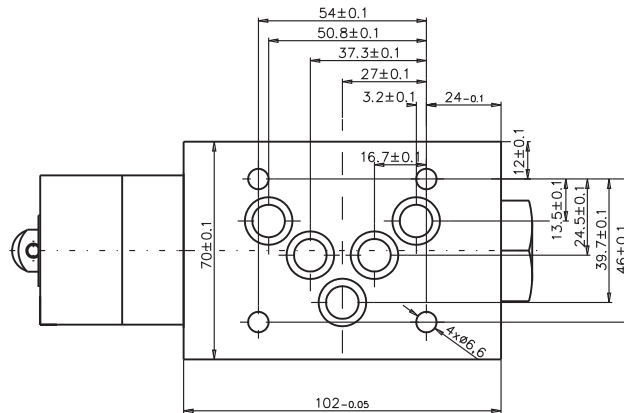

Symbols 12 , 17 , 24 , 27 , 34 , 39 , 45 , 68 , 70 , 83

Symbols 10 , 13 , 16 , 28 , 32 , 36 , 64 , 78

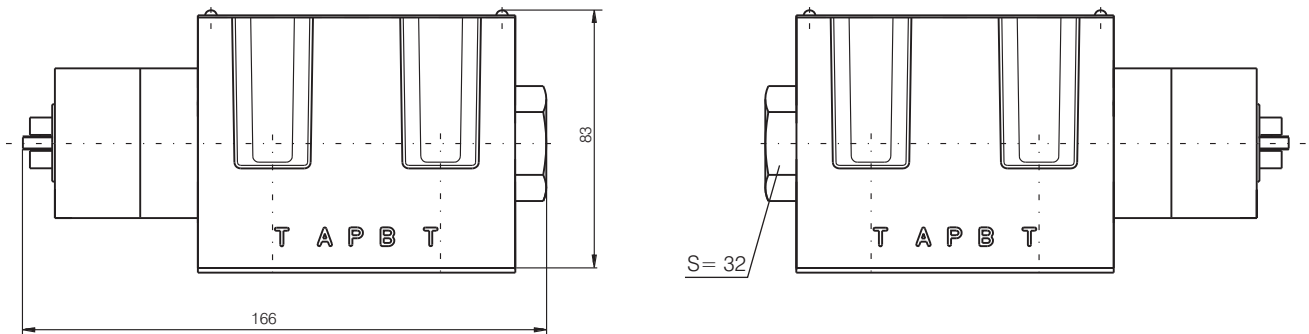

ACCESSORIES

SUBPLATES

Subplate is as at RH10...1-...F... see page 23.

SEALS

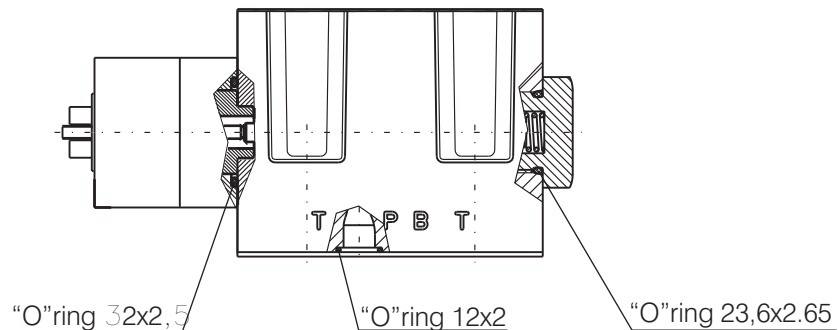

BACKING

Backing of the housing is as at RH10...1-...F... see page 24.

GENERAL DESCRIPTION

- ✓ 4/3- and 4/2- way directional control valves with manual operation
- ✓ Reliability and long life
- ✓ Mounting surface CETOP5 ; NG10

RH10...7F...

The RH10...7F.. valves consist of a spool , housing , springs and manual control. The valves are used for hydraulic power control. This model is designed with two-spring centered spool about 4/3- and 4/2- valves. The housing has 5-chambers and vertical "T" duct. There are two possible versions of valve - with detent and without detent. The valve location during assembly is of minor importance , but the horizontal position is generally recommended.

ORDERING CODE

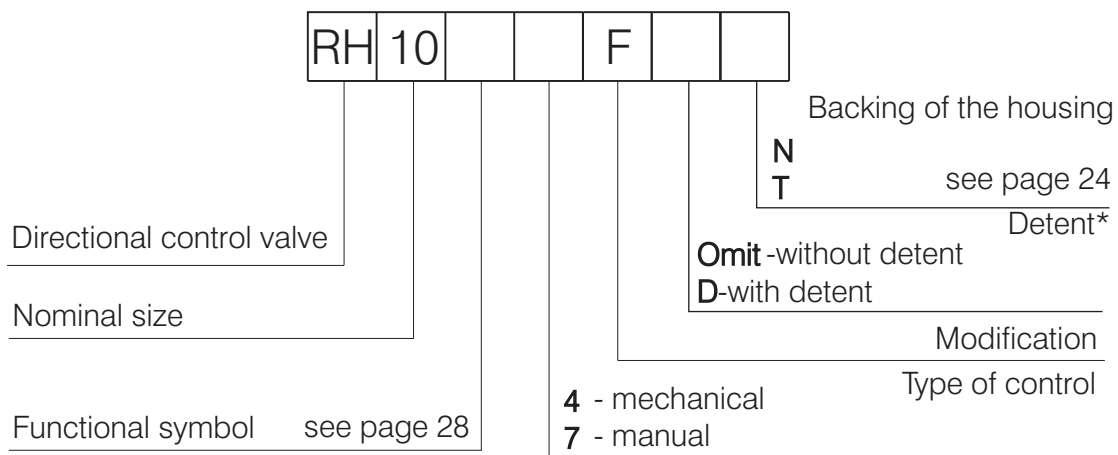

* Only for type of control 7-manual

FUNCTIONAL SYMBOLS

DESIG-NATION	SYMBOL	INTERMEDIATE	Type of control		DESIG-NATION	SYMBOL	INTERMEDIATE	Type of control	
			4 	7 				4 	7
00				✓	28			✓	✓
01				✓	32			✓	✓
02				✓	33			✓	✓
04				✓	36			✓	✓
05				✓	39			✓	✓
06				✓	40				✓
10			✓	✓	41				✓
11				✓	42				✓
12			✓	✓	45			✓	✓
13			✓	✓	61				✓
14			✓	✓	62				✓
16			✓	✓	64			✓	✓
17			✓	✓	68			✓	✓
18				✓	70			✓	✓
21				✓	83			✓	✓
24			✓	✓					
26				✓					
27			✓	✓					

For three positional valves (code 7-manually) the operator is at side "a" except symbols 42 , 61 and 62 , which operator is at side "b". For two positional valves see the table above. Other symbols on request.

TECHNICAL DATA

DATA		UNIT	VALUE/RANGE
Weight		kg	5,1
Max. pressure	port P , A & B port T	MPa	32 16
Rated flow	(at $\Delta p=0,1\text{MPa}$)	l/min	15...45
Angular movement		°	± 29
Actuating force		N	30

DIMENSIONS

All dimensions are shown in mm. The other dimensions and requirements are as RH10...1...F-see page 20.

THREE POSITIONAL

Symbols 00 , 01 , 02 , 04 , 05 , 06 , 11 , 12 ,
14 , 17 , 18 , 21 , 24 , 26 , 27 , 39 , 40 ,
41 , 45 , 68 , 70 , 83(except 42 , 61 , 62)

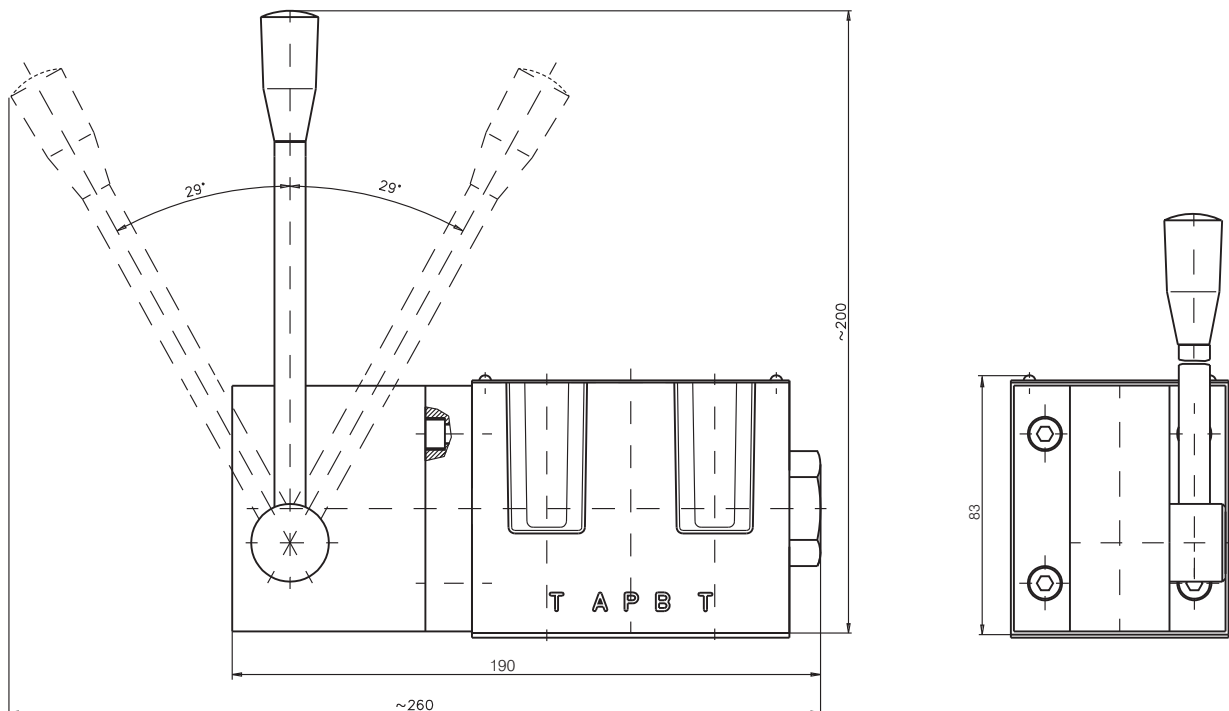
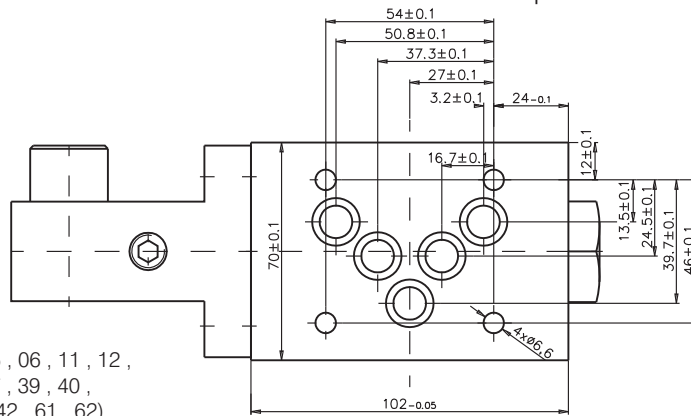

For three positional valves symbols 42 , 61 and 62 the operator is at side "b".

DIMENSIONS

TWO POSITIONAL

Symbols 11, 12, 14, 17, 24,
27, 39, 45, 68, 70, 83

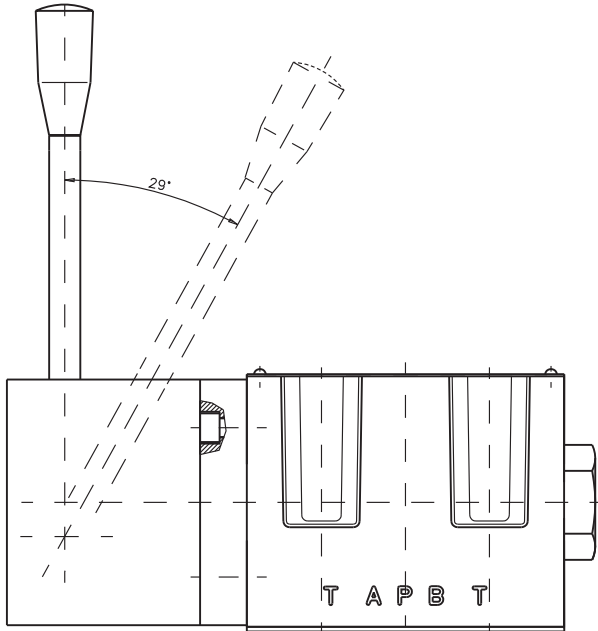

TWO POSITIONAL

Symbols 10, 13, 16, 28, 32,
33, 36, 64

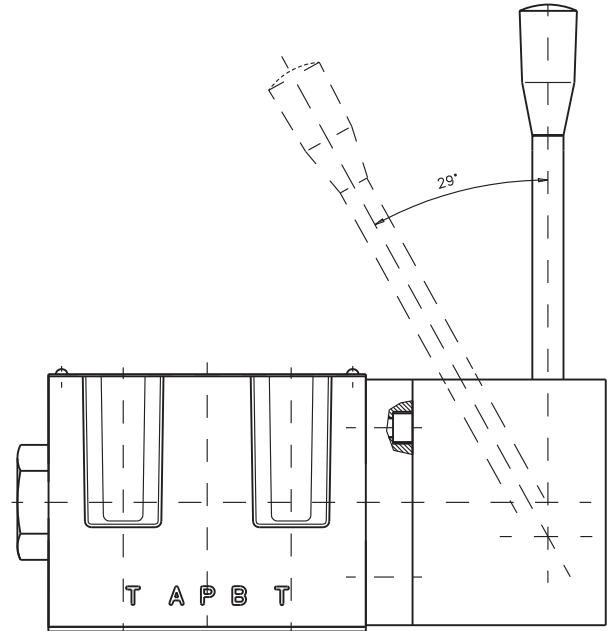

ACCESSORIES

SUBPLATES

Subplate is as at RH10...1-...F... see page 23.

SEALS

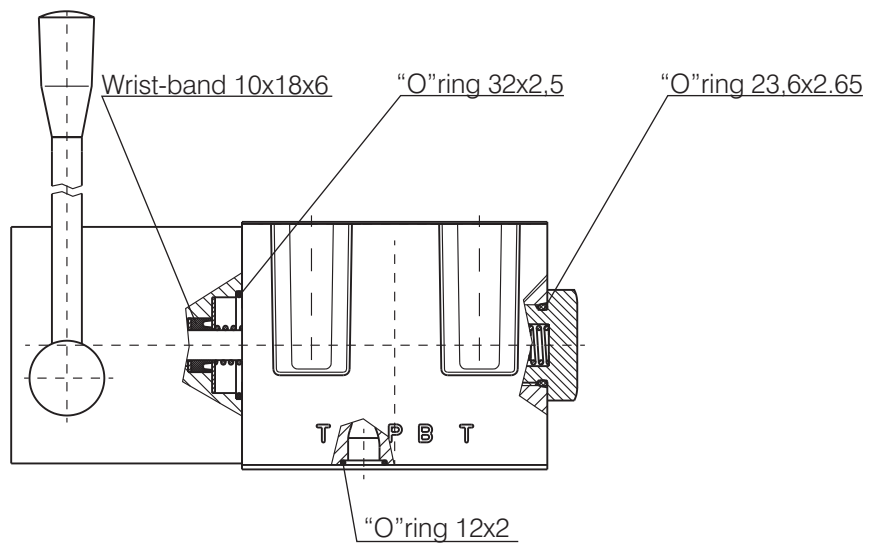

BACKING

Backing of the housing is as at RH10...1-...F... see page 24.

GENERAL DESCRIPTION

RH06...1-.../...GF.....

- ✓ 4/3- and 4/2- way directional control valves with solenoid operation
- ✓ Thread connection of working ports "A" and "B" except RH06...1-.../...GFS modification
- ✓ Up to 8 sections for horizontal stacking & up to 4 sections for vertical stacking

The RH06...1-.../...GF... valves consist of a spool, housing, springs and solenoids.

The valves are used for hydraulic power control. These modifications are designed with two-spring centered spool about 4/3- and 4/2- valves. The housing has 5-chambers and a horizontal "T" duct. Working ports "A" and "B" are threaded directly into the valve housing except RH06...1-.../...GFS modification.

The valve location during assembly is of minor importance, but the horizontal position is generally recommended. For the functional symbols "08" and "20" - the horizontal position is obligatory.

RH06...1-.../...GF... model is designed as a peak plate, when we realize modular mounting of directional control valves type RH06...1-.../...GFM... and they are used for vertical stacking - see next page.

RH06...1-.../...GFS..., RH06...1-.../...GFST... & RH06...1-.../...GFSTS... are designed for horizontal stacking.

All these modifications supersedes completely those with plate, but with less cost and the maximum flow is reduced - max. flow - 50l/min.

Scheme for vertical stacking

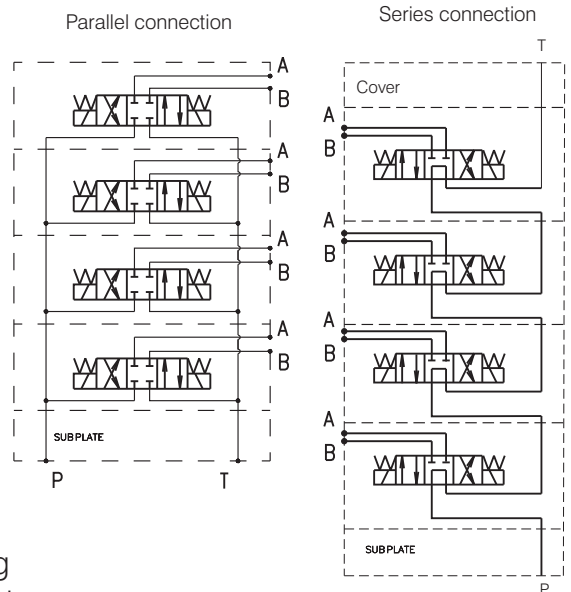

Scheme for horizontal stacking

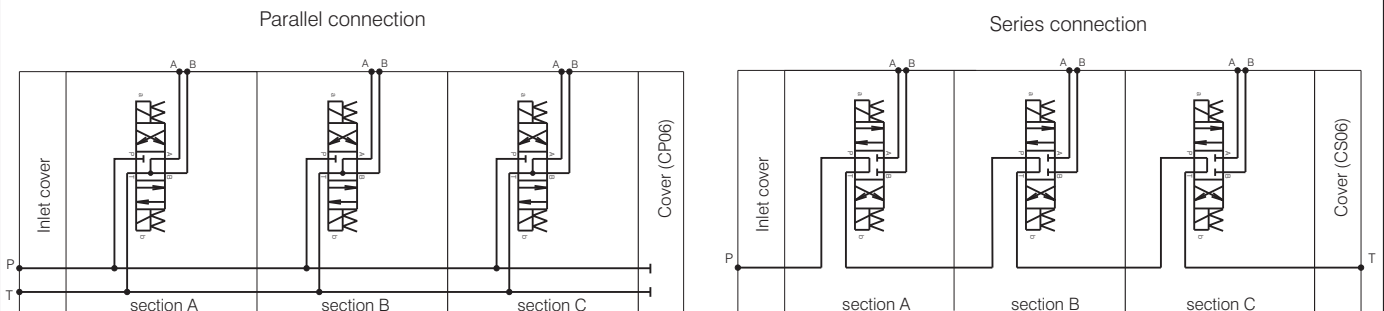

RH06...1-.../...GF.....-parallel connection

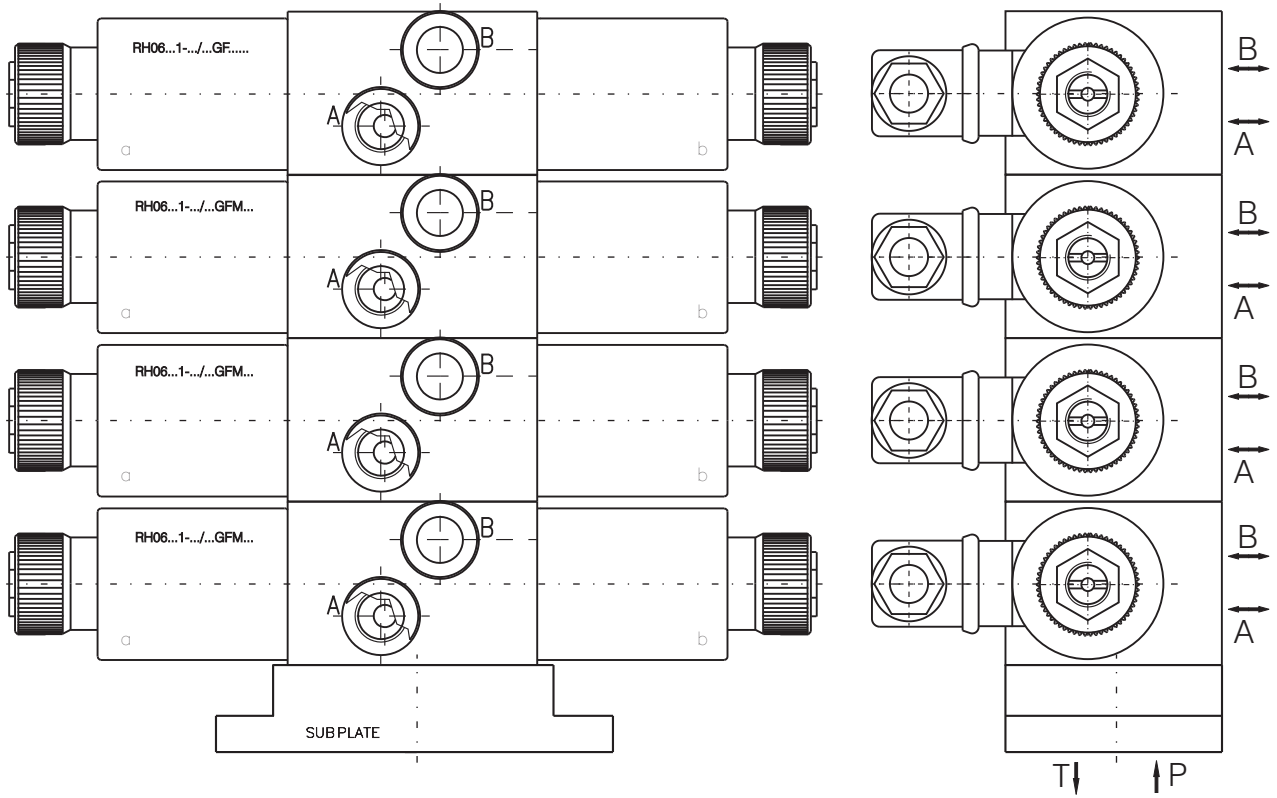

RH06...1-.../...GF.....-series connection

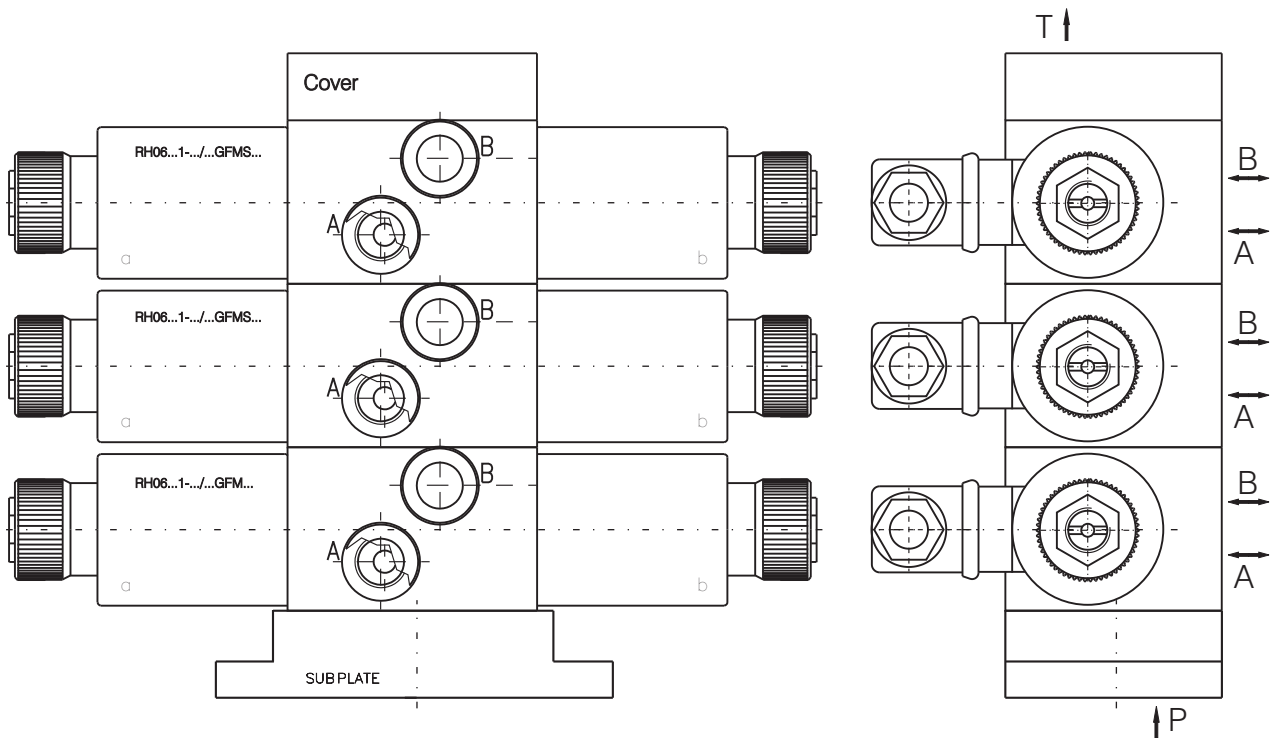

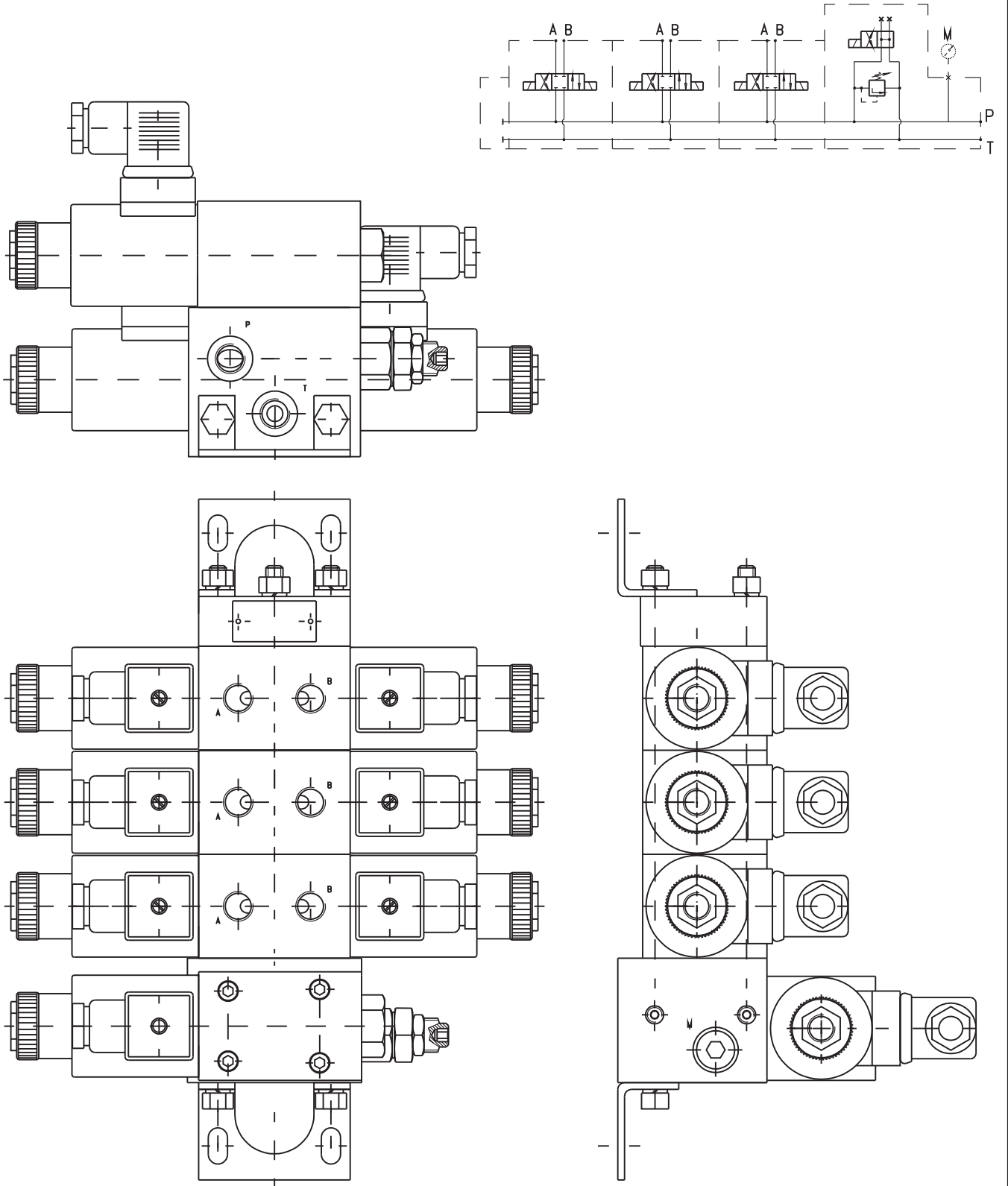

ORDERING CODE

RH	06		1	-	.../...	G...				
----	----	--	---	---	---------	------	--	--	--	--

Directional control valve

Nominal size

 Functional symbol
see page 3

Type of control: -electrical

 Supply voltage/current frequency
see page 7

 Modification
see pages 35...40

 Connectors
see page 7

 Backing of the housing
see page 8

Threads at A & B ports**

Screw cap

 012/00
024/00
110/50
220/50

 GF
GFM
GFMS
GFS
GFST
GFSTS

 C1
C2
C3
C4
C5

 N
T

 M14x1,5- **Omit**
M16x1,5- **M1**
M18x1,5- **M2***
G3/8"- **G1**
G1/4"- **G2**

 with plastic cap- **Omit**
with metal cap- **M**

 * Only for GFST & GFSTS modification
** These options are not valid for GFS modification

FUNCTIONAL SYMBOLS

DESIG-NATION	SYMBOL	INTERMEDIATE	DESIG-NATION	SYMBOL	INTERMEDIATE	DESIG-NATION	SYMBOL	INTERMEDIATE
00			08			16		
01			10			20*		
02			11			24		
04			12			28		
33			14			45		

20*-with detent

TECHNICAL DATA

Maximum flow 50l/min-depends on symbols. Max. operating pressure when it is used the series connection is 160bar. The other technical data are the same as at solenoid operated directional control valves-RH06...1-.../...F...-see page 4

DIMENSIONS

All dimensions are shown in mm.

RH06...1-.../...GF...

with solenoids "a" & "b"
for symbols: "00", "01", "02", "04", "05", "08" and "20"

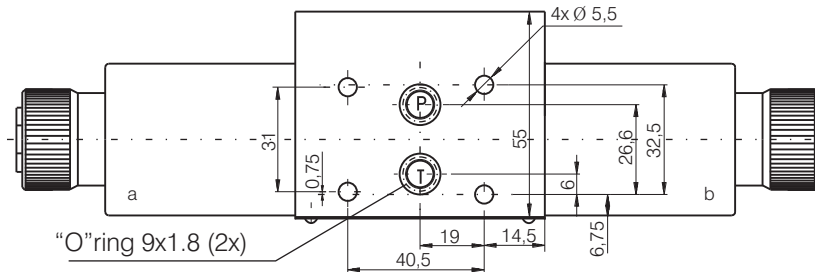

For one-lead supply scheme, the metal screw cap should be used-code M-see page 34.

Standard fixing bolts are M5x50 (10,9 class recommended). Torque 6...8 Nm.

The plug connectors are grey or white for solenoid "a", black for solenoid "b" and transparent for solenoids with light indicator.

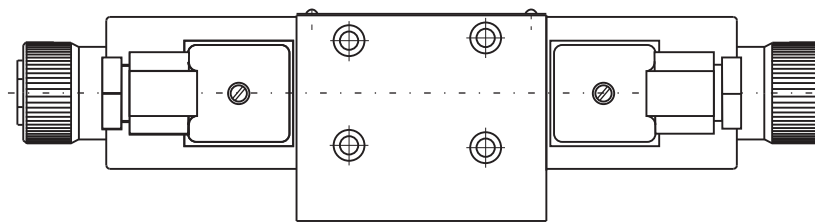
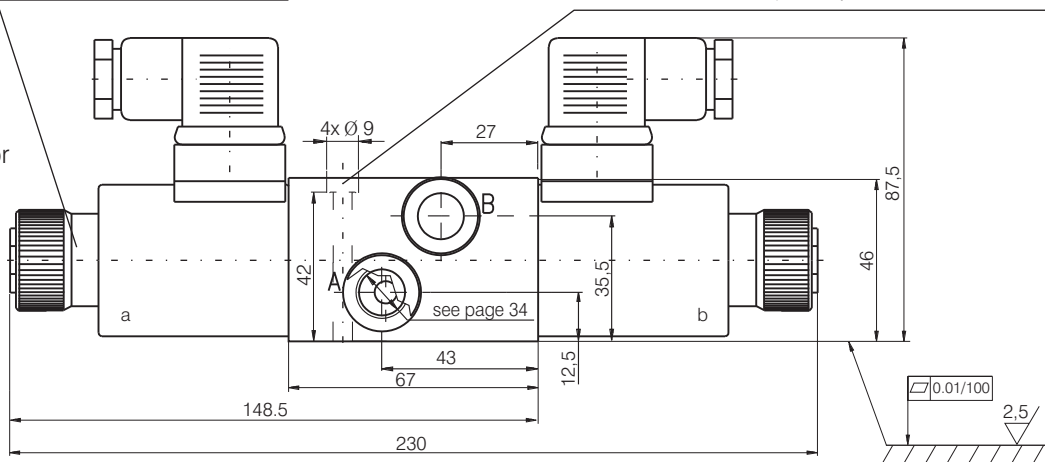

with solenoid "a"
for symbols: 11, 12, 14, 17, 24, 33 and 45

with solenoid "b"
for symbols: 10, 16 and 28

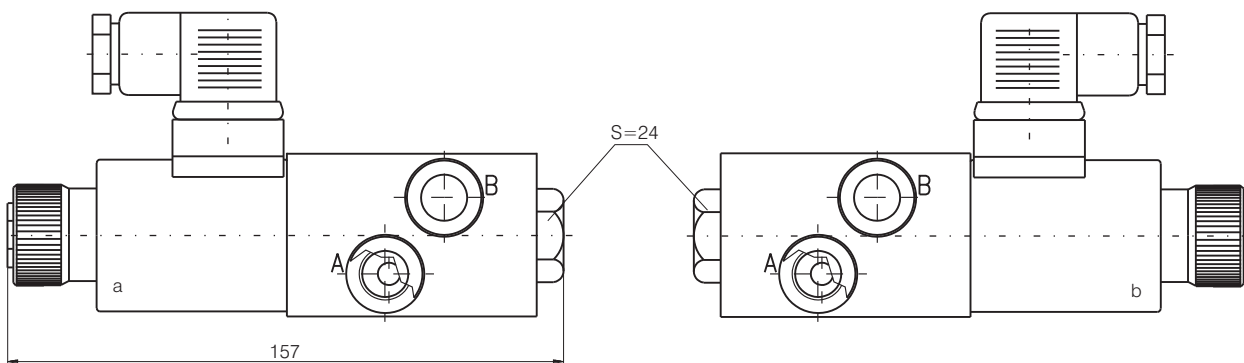

The other dimensions are the same as double solenoid valve.

DIMENSIONS

All dimensions are shown in mm.

with solenoids "a" & "b"
for symbols: "00", "01", "02", "04", "05", "08" and "20"

RH06...1-.../...GFM...

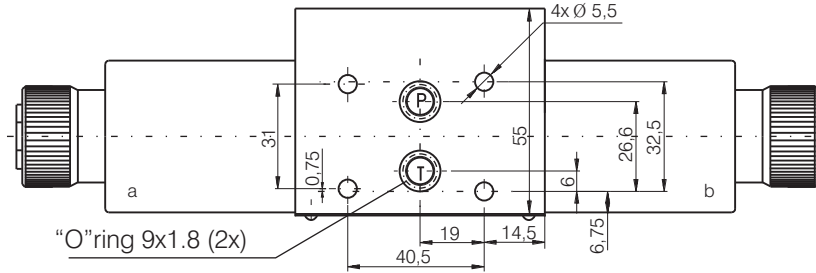

For one-lead supply scheme, the metal screw cap should be used-code M-see page 34.

The plug connectors are grey or white for solenoid "a", black for solenoid "b" and transparent for solenoids with light indicator.

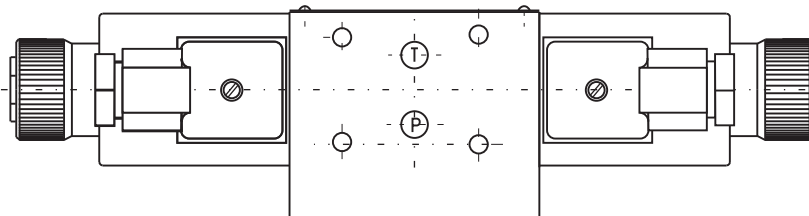
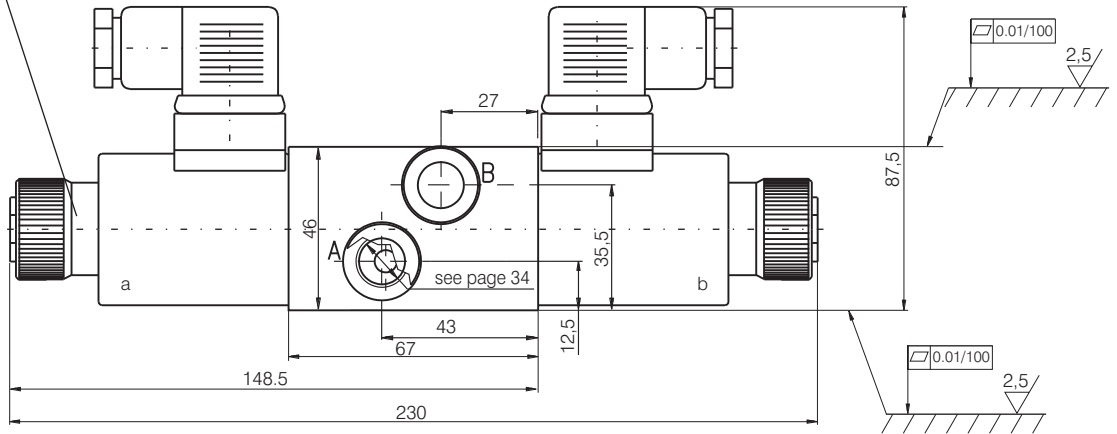

with solenoid "a"
for symbols: 11, 12, 14, 17, 24, 33 and 45

with solenoid "b"
for symbols: 10, 16 and 28

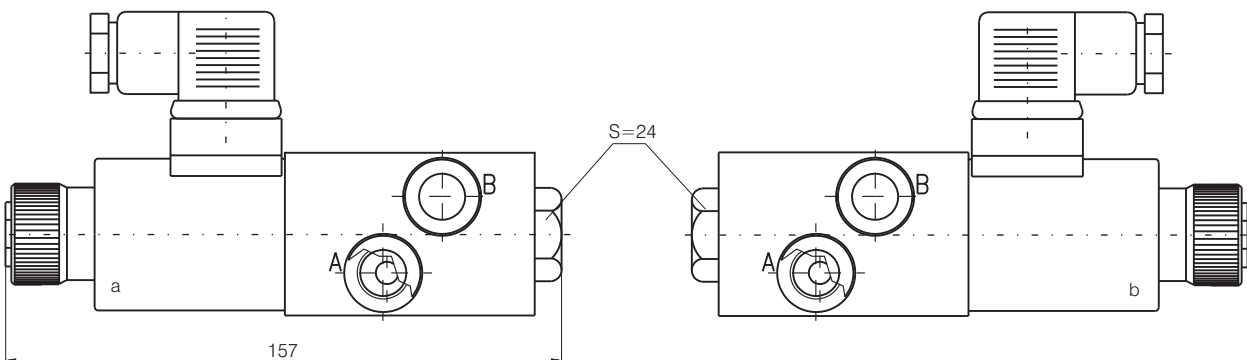

The other dimensions are the same as double solenoid valve.

DIMENSIONS

All dimensions are shown in mm.

RH06...1-.../...GFMS...

with solenoids "a" & "b"
for symbols: "00", "01", "02", "04", "05", "08" and "20"

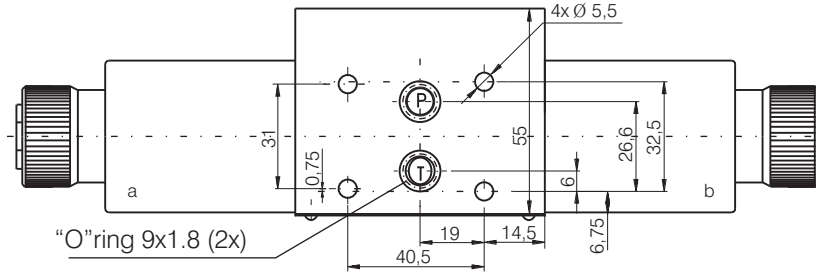

For one-lead supply scheme, the metal screw cap should be used-code M-see page 34.

The plug connectors are grey or white for solenoid "a", black for solenoid "b" and transparent for solenoids with light indicator.

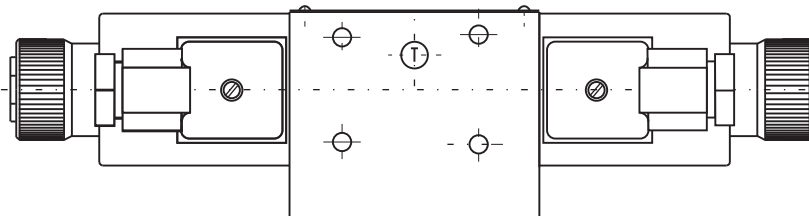
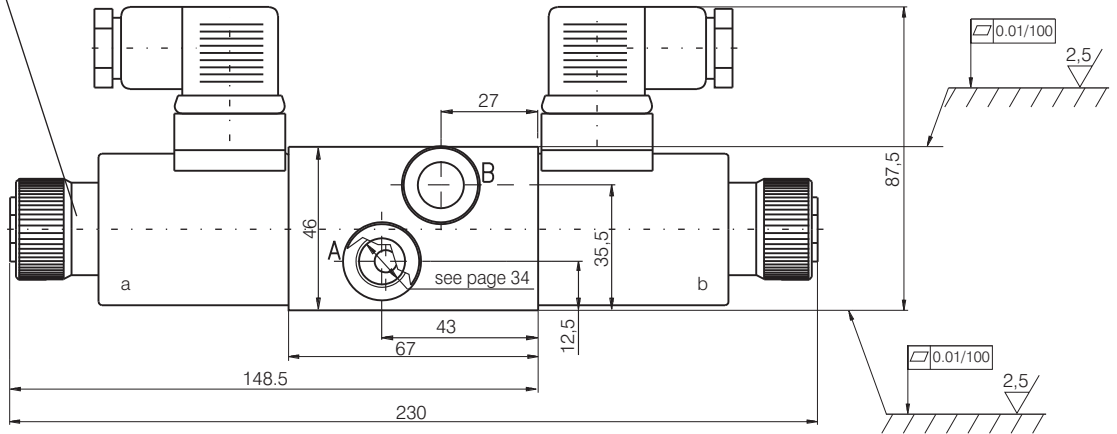

with solenoid "a"
for symbols: 11, 12, 14, 17, 24, 33 and 45

with solenoid "b"
for symbols: 10, 16 and 28

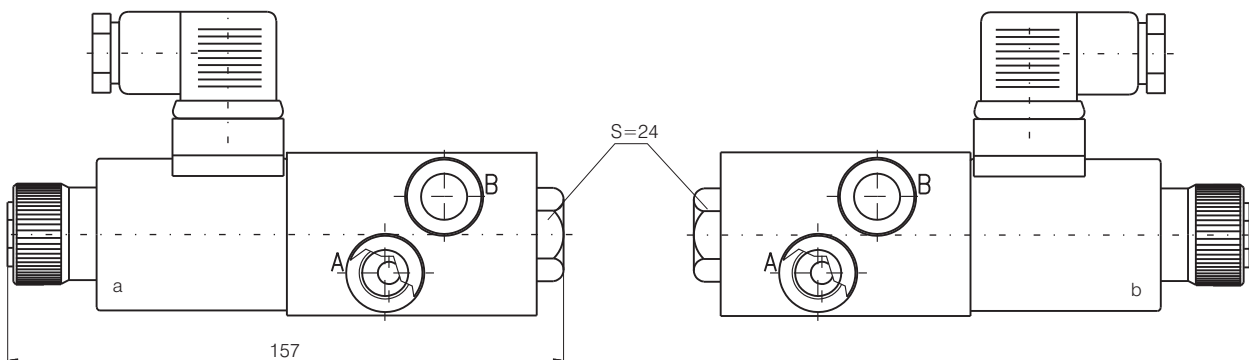

The other dimensions are the same as double solenoid valve.

DIMENSIONS

All dimensions are shown in mm.

with solenoids "a" & "b"
for symbols: "00", "01", "02", "04", "05", "08" and "20"

RH06...1-.../...GFS...

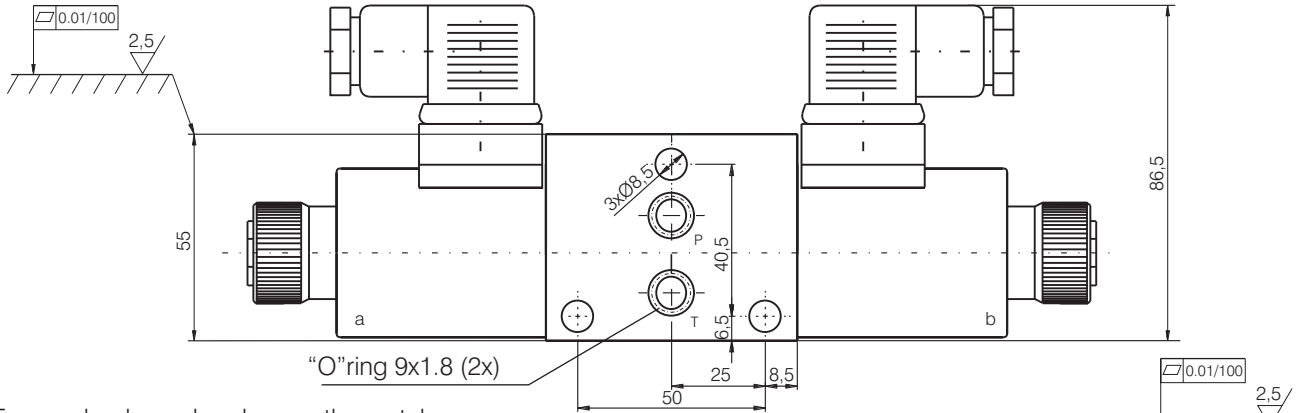

For one-lead supply scheme, the metal screw cap should be used-code M-see page 34.

The plug connectors are grey or white for solenoid "a", black for solenoid "b" and transparent for solenoids with light indicator.

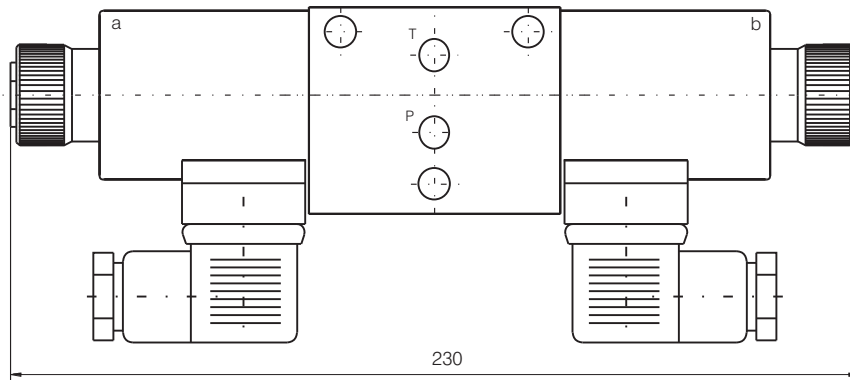
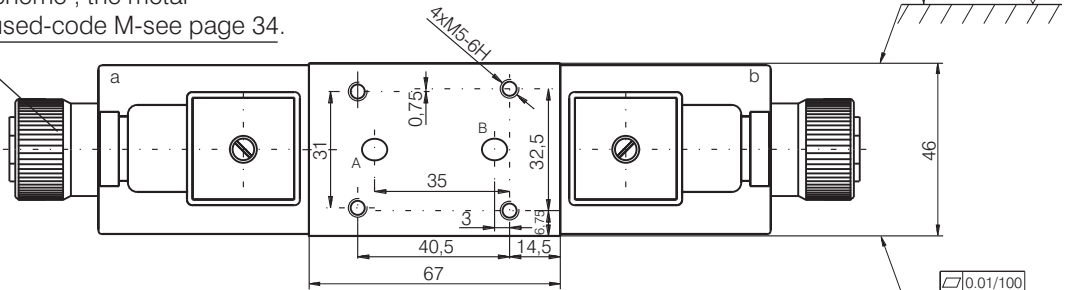

with solenoid "a"
for symbols: 11, 12, 14, 17, 24, 33 and 45

with solenoid "b"
for symbols: 10, 16 and 28

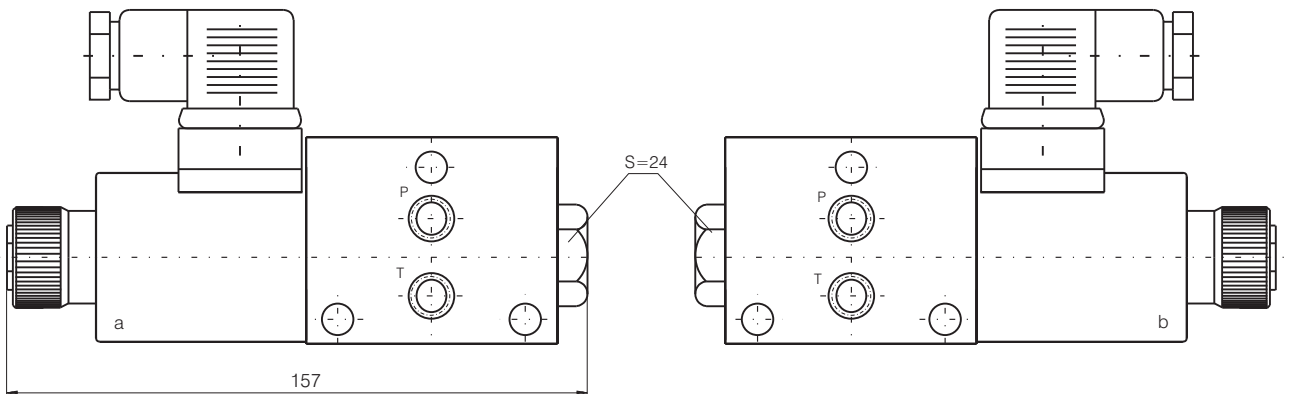

The other dimensions are the same as double solenoid valve.

This valve is useful only for vertical building up SVM06-... see pages 45 and 46.

DIMENSIONS

All dimensions are shown in mm.

with solenoids "a" & "b"
for symbols: "00", "01", "02", "04", "05", "08" and "20"

RH06...1-.../...GFST...

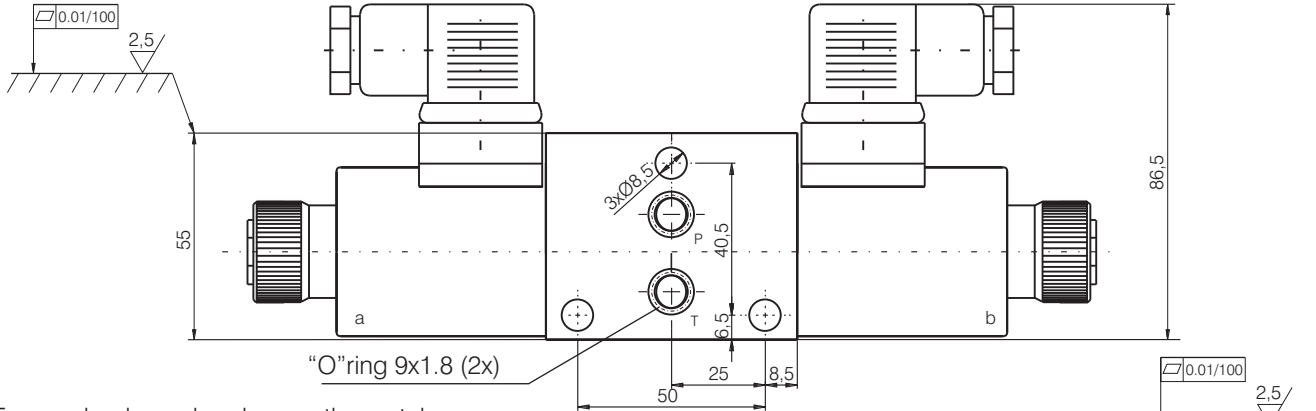

For one-lead supply scheme, the metal screw cap should be used-code M-see page 34. see page 34.

The plug connectors are grey or white for solenoid "a", black for solenoid "b" and transparent for solenoids with light indicator.

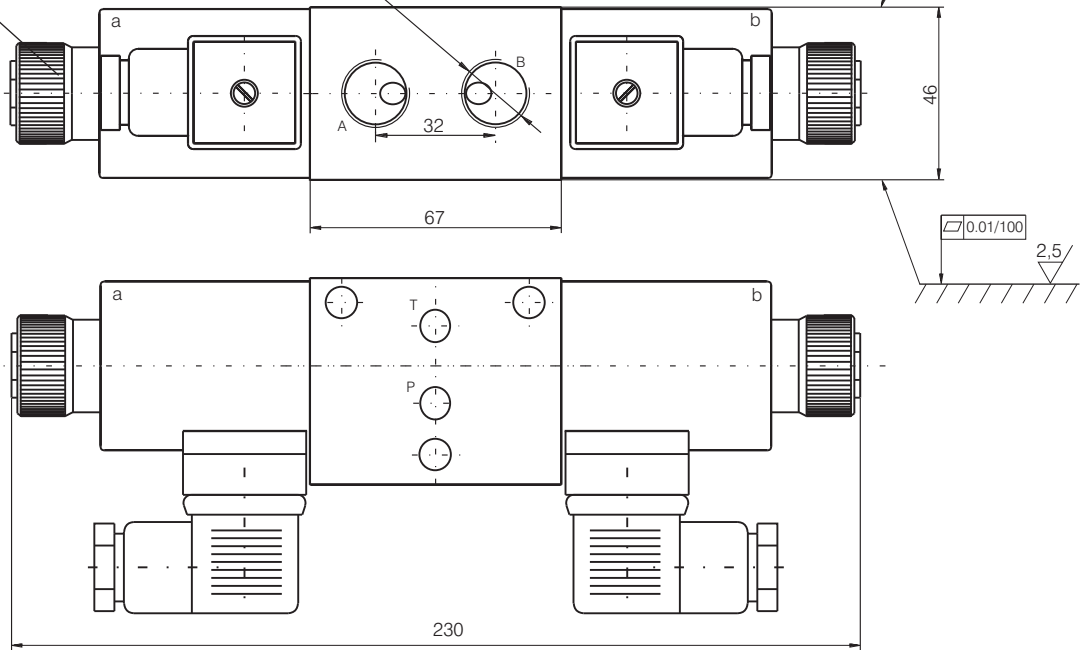

with solenoid "a"
for symbols: 11, 12, 14, 17, 24, 33 and 45

with solenoid "b"
for symbols: 10, 16 and 28

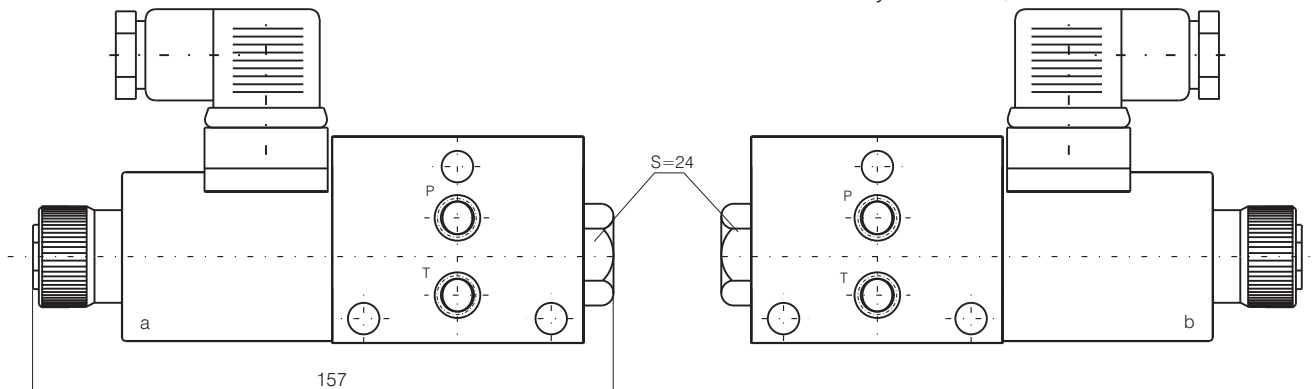

The other dimensions are the same as double solenoid valve.

DIMENSIONS

All dimensions are shown in mm.

with solenoids "a" & "b"
for symbols: "00", "01", "02", "04", "05", "08" and "20"

RH06...1-.../...GFSTS...

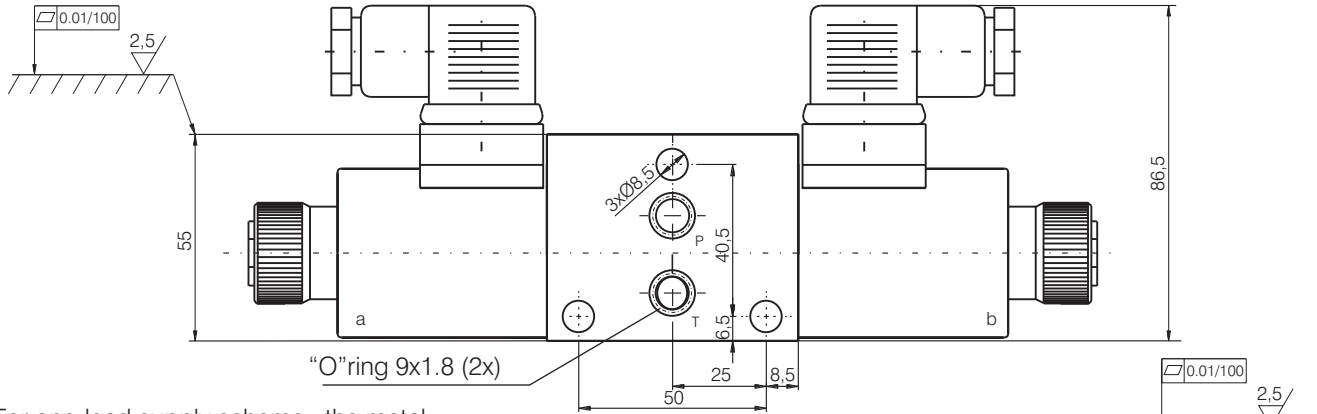

For one-lead supply scheme, the metal screw cap should be used-code M-see page 34. see page 34.

The plug connectors are grey or white for solenoid "a", black for solenoid "b" and transparent for solenoids with light indicator.

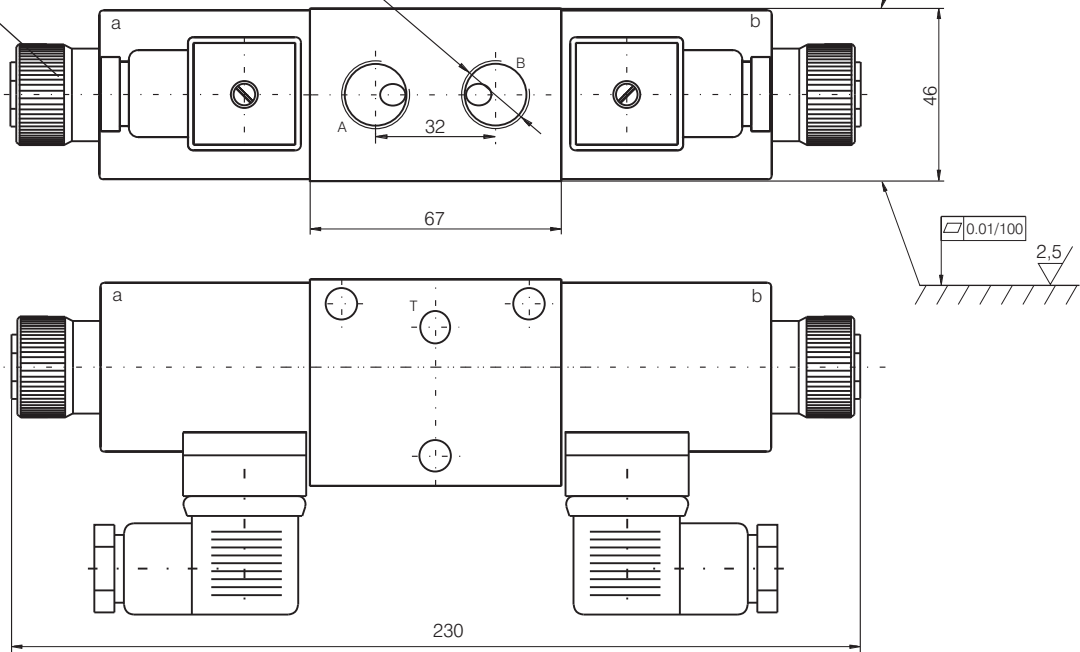

with solenoid "a"
for symbols: 11, 12, 14, 17, 24, 33 and 45

with solenoid "b"
for symbols: 10, 16 and 28

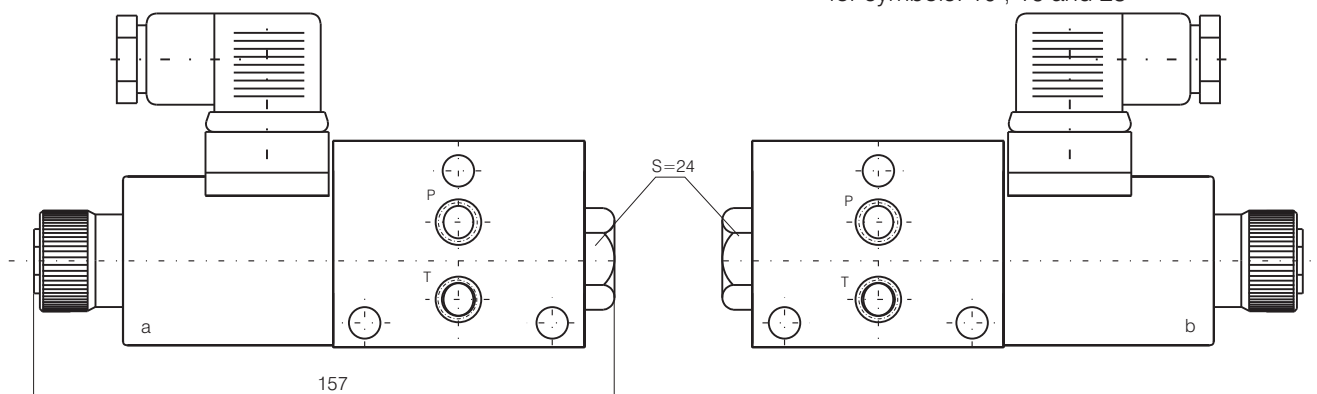

The other dimensions are the same as double solenoid valve.

SOLENOIDS

Solenoids are the same as RH06...1-.../...F - see page 7.

ACCESSORIES

SUBPLATES

All dimensions are shown in mm. Subplates are available with GF , GFM and GFMS modification (vertical stackable control blocks).

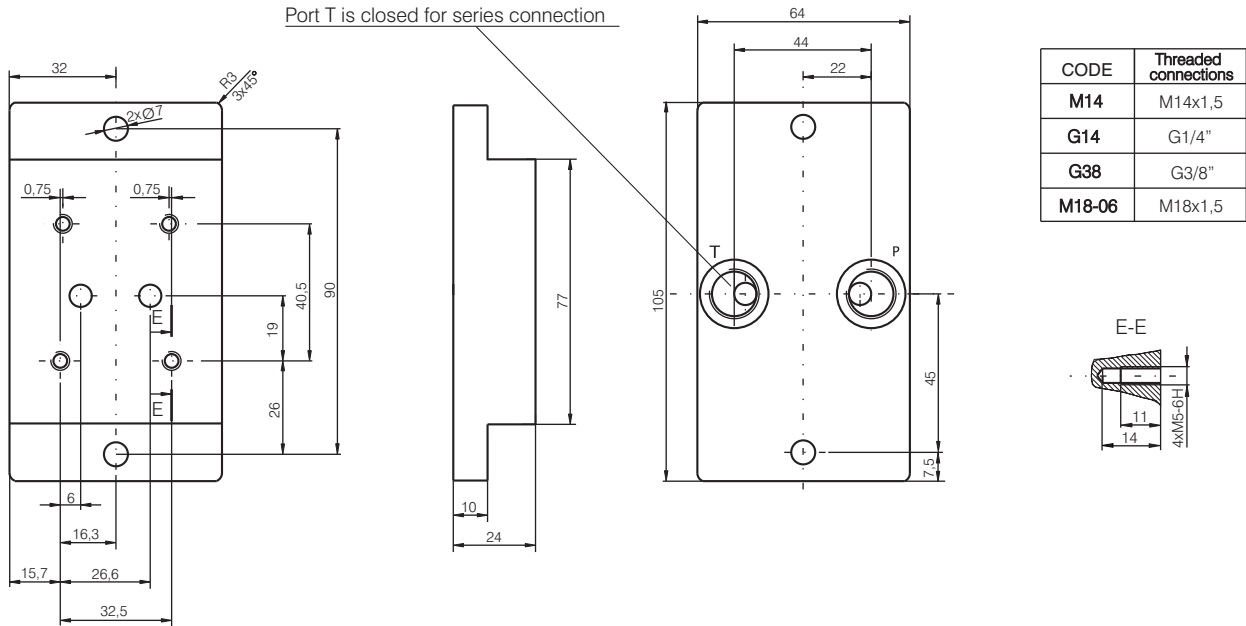

OUTLET COVER

Outlet covers are available with horizontal stackable control blocks with vertical building up - OC06... and with vertical stackable control blocks as peak plate when we realized series connection - OCVS06....

Code OCVS06 see page 44

Code OC06... see page 44

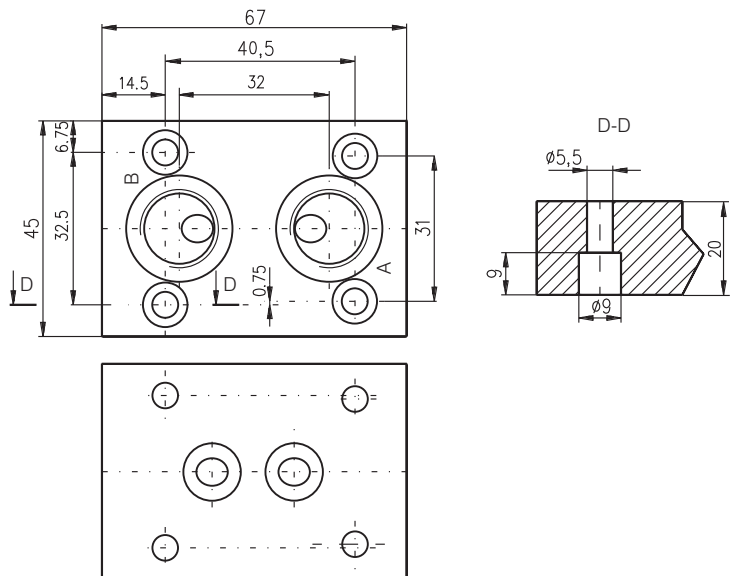
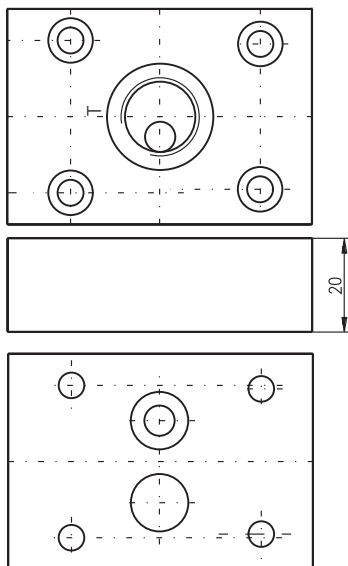

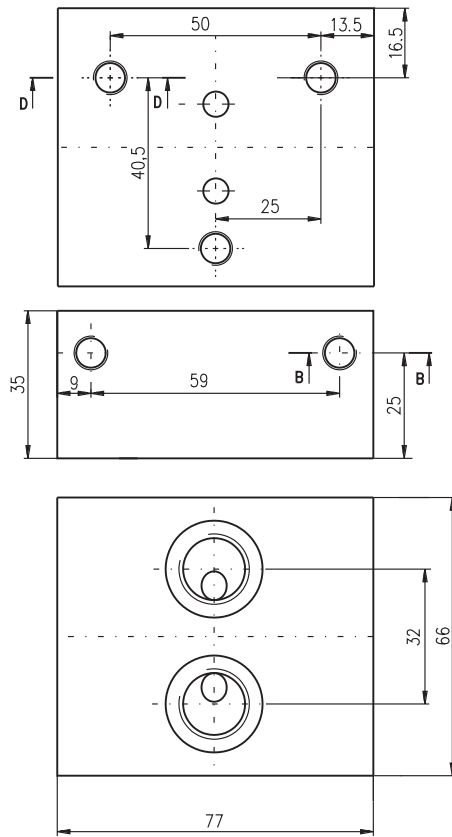

Inlet covers are available only with GFS , GFST & GFSTS modification (horizontal stackable control blocks).

Code IC06... see page 44

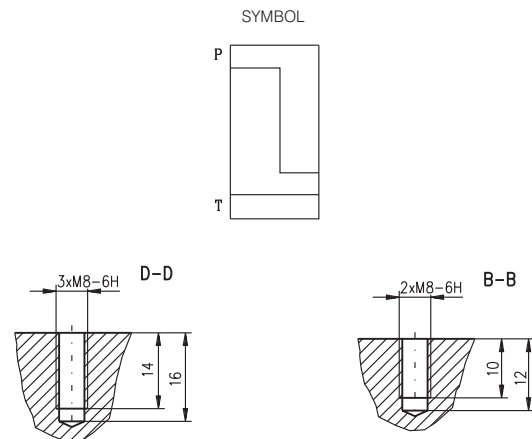

Different configurations on request

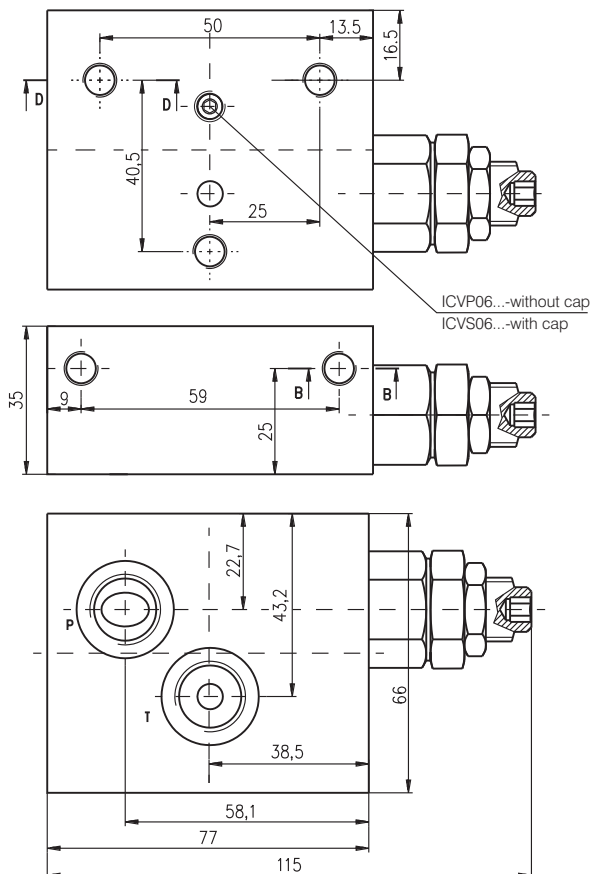

Code ICVP06.../ICVS06... see page 44

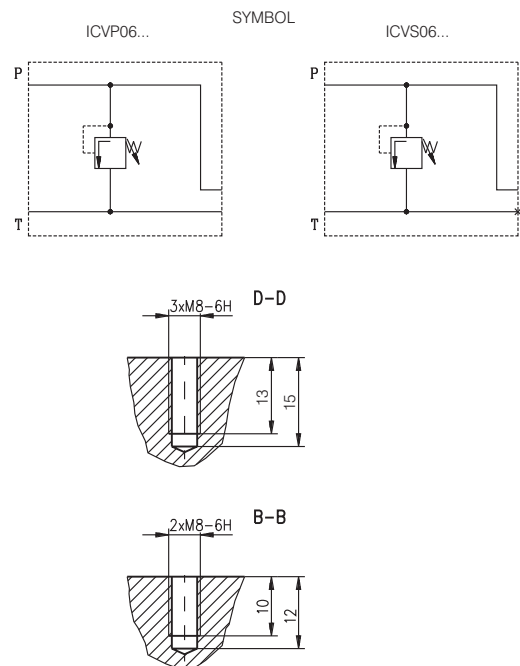

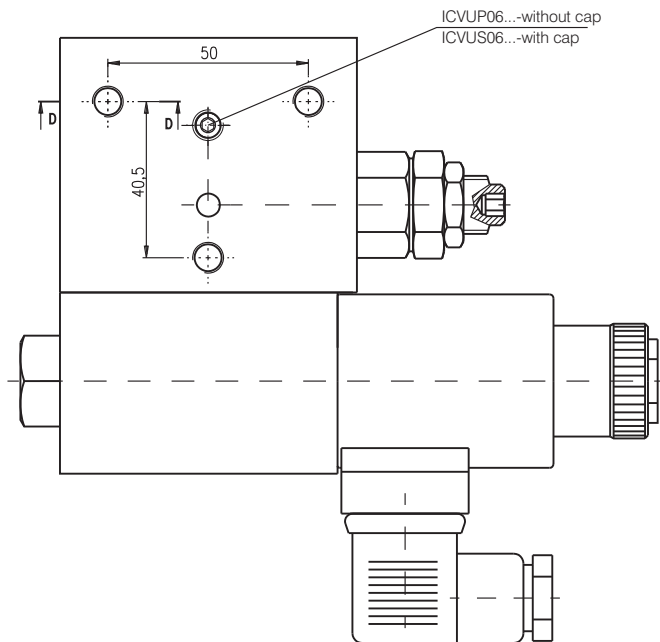

Inlet covers are available only with GFS , GFST & GFSTS modification (horizontal stackable control blocks).

Code ICVUP06.../ICVUS... see page 44

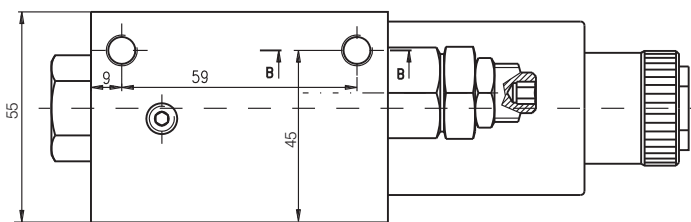

SYMBOL

ICVUP06...

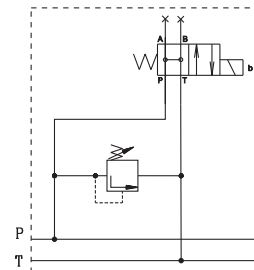

ICVUS06...

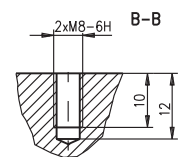
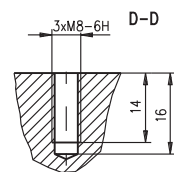
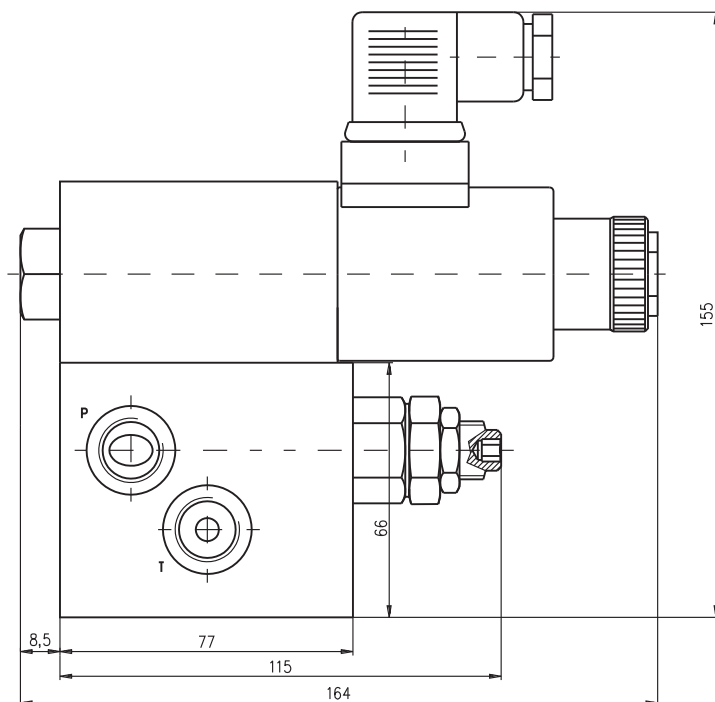
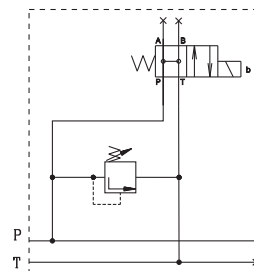

COVERS

Covers are available only with GFS, GFST and GFSTS modifications (horizontal stackable control blocks).

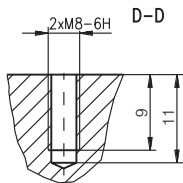

Code CP06 see below

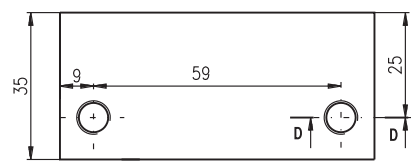
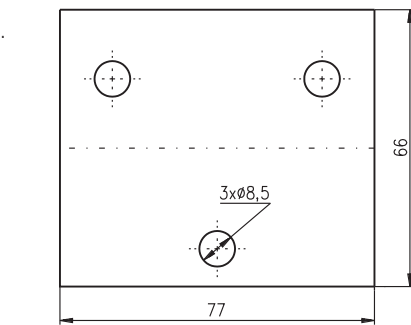

Code CS06... see below

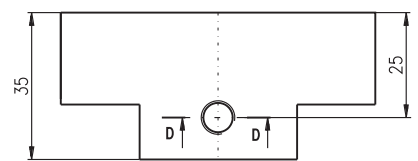
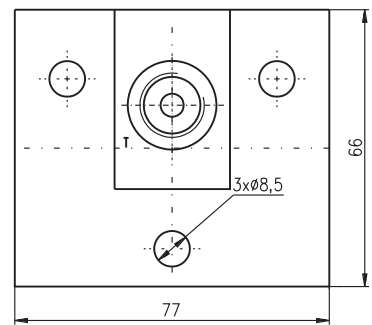

SYMBOL

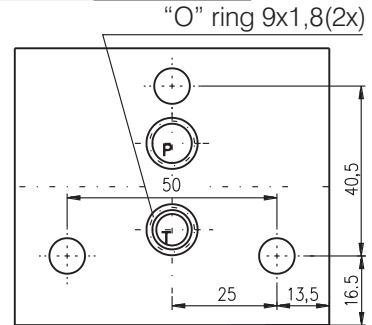
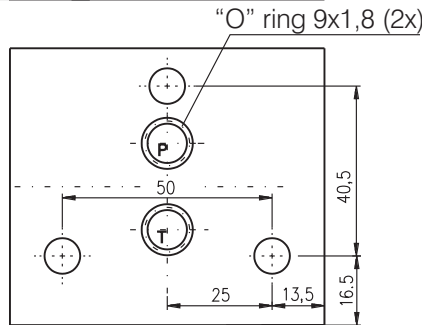
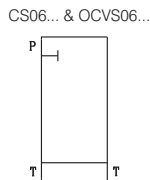
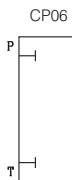

ORDERING CODE FOR ALL COVERS

- Cover: inlet cover (for horizontal stacking) - without valves
- with relief valve for parallel connection
- with relief valve for series connection
- with relief & unloading valves for series connection
- with relief & unloading valves for parallel connection
- outlet cover (for horizontal stacking and vertical building up)
- outlet cover (for vertical stacking and series connection)
- cover (for horizontal stacking) - parallel
- series

Nominal size

Connection threads:

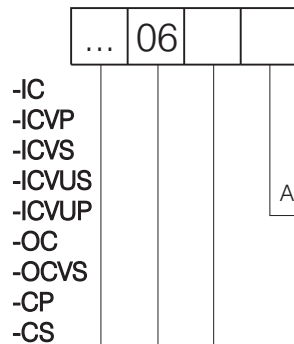

- IC
- ICVP
- ICVS
- ICVUS
- ICVUP
- OC
- OCVS
- CP
- CS

- M14x1,5 -Omit
- M16x1,5 -M1
- G3/8" -G1
- G1/4" -G2

Additional information

SEALS

See page 8.

BACKING

See page 8.

GENERAL DESCRIPTION

SVM06...-...

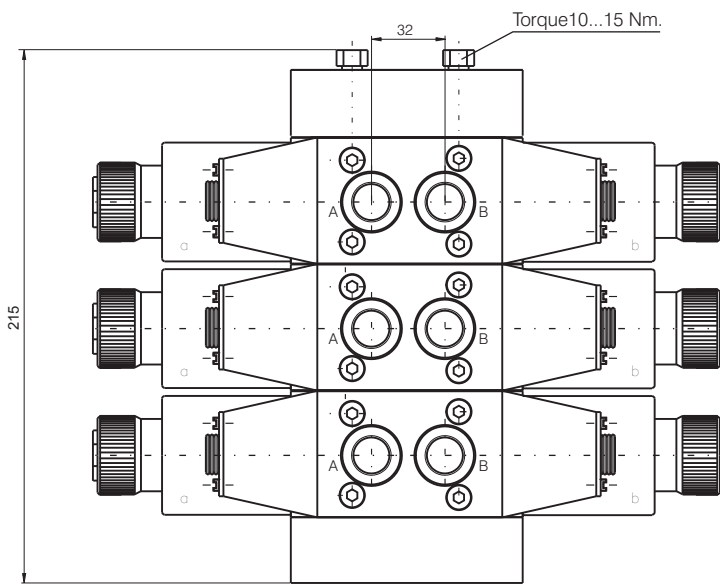
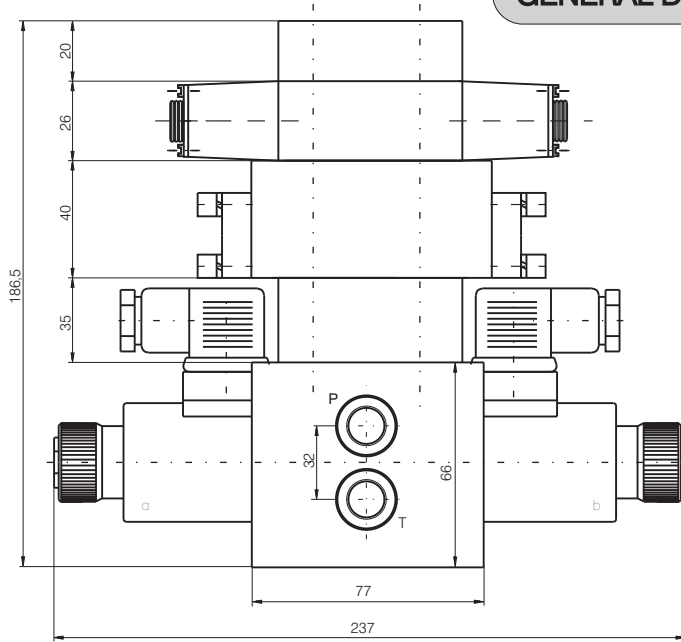

- ✓ 4/2 and 4/3 - way directional control valves with solenoid operation made up with inlet cover , outlet cover and cover.
- ✓ Thread connection of ports "A" , "B" "P" and "T".
- ✓ Possibility of vertical building up with pilot operated check valve , throttle check valve or both standard component.
- ✓ Up to 8 sections.
- ✓ Possibility of parallel and series connection.

Directional control valves are stackable type RH06...1-.../...GFS...-for vertical building up , and RH06...1-.../...GFST...& RH06...1-.../...GFSTS... - for horizontal stacking.

The stackable valves for vertical building up are standard version CETOP 3.

Parallel connection

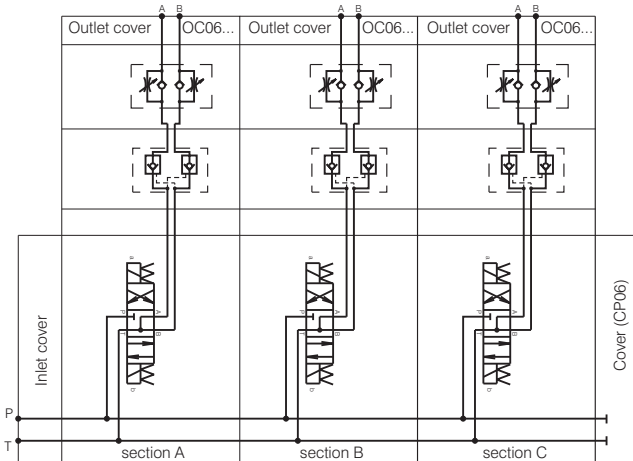

Series connection

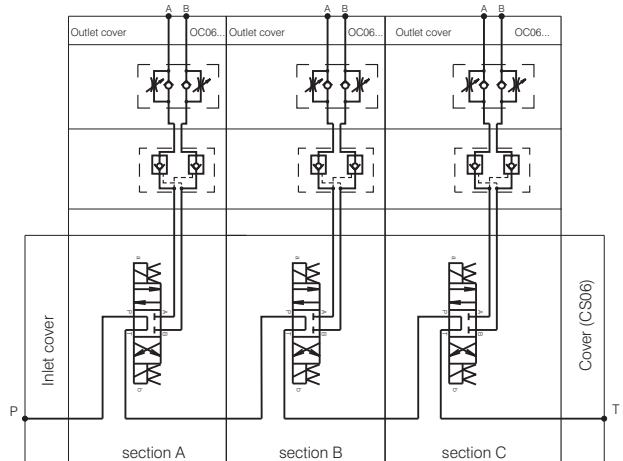

GENERAL DESCRIPTION

SVM06...-...

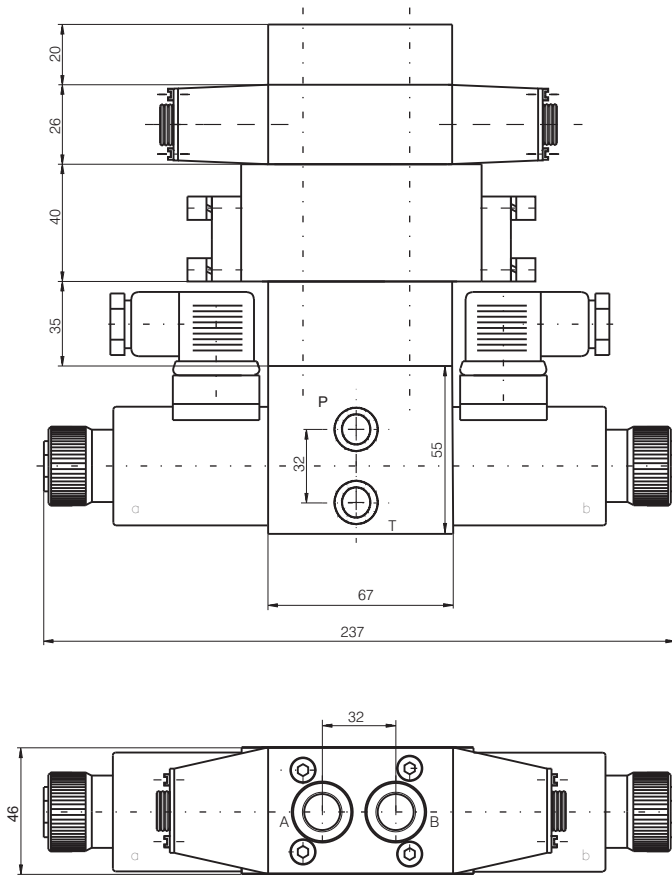

Every section can have the following configurations as shown below:

- directional control valve with pilot operated check valve and adjustable throttle check valve ,
- directional control valve with pilot operated check valve ,
- directional control valve with adjustable throttle check valve.
- directional control valve without valves.

A(B,C,D,E,F)...-without symbol

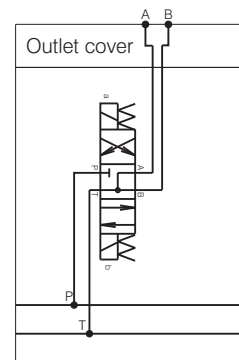

POSSIBLE VERSIONS*

A(B,C,D,E,F)...-KD

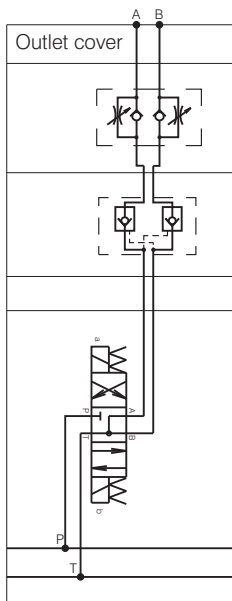

A(B,C,D,E,F)...-K

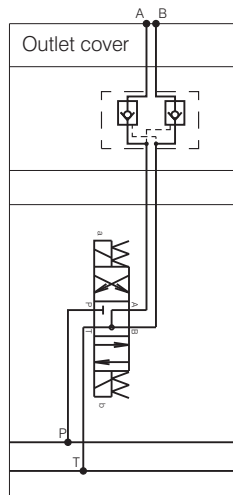

A(B,C,D,E,F)...-D

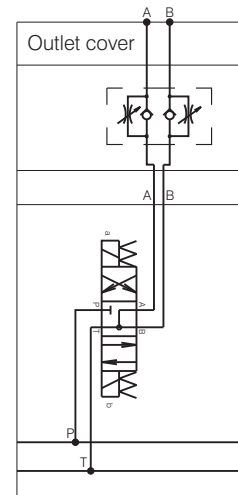

* Codifications-see page 47 "ORDERING CODE" marked with *.

ORDERING CODE

Horizontal stacking

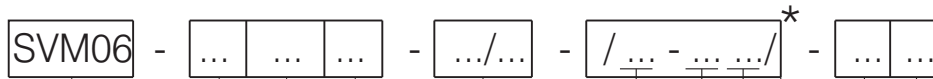

Stackable valve nominal size 06

Number of section - up to 8

Inlet cover: without cover - **Omit**
 without valve - **IC06**
 with pressure relief valve - **ICVP06 or ICVS06**
 with pressure relief & unloading valves - **ICVUP06 or ICVUS06**

see page 44

Modification of directional control valve: GFS - **GFS**
 GFST - **GFST**
 GFSTS - **GFSTS**

see pages 38...40

Supply voltage/current frequency:

012/00
024/00
110/50
220/50

see page 7

Stackable valves: repeat for each section

first section - **A**
 second section - **B**
 third section - **C**
 fourth section - **D**
 fifth section - **E**
 sixth section - **F**

functional symbol of directional control valve
 see page 34

without valves - **Omit**
 with pilot operated check - **KD**
 valve & throttle check valve with pilot operated check - **K**
 with throttle check valve - **D**

see page 46

Cover:

without cover - **Omit**
 "P" & "T" - blocked - **CP06**
 "P" -blocked , "T" -passage - **CS06**

see page 44

Threads P , T , A & B ports:

M14x1,5- **Omit**
 M16x1,5- **M1**
 G3/8"- **G1**
 G1/4"- **G2**

ORDERING CODE

Vertical stacking

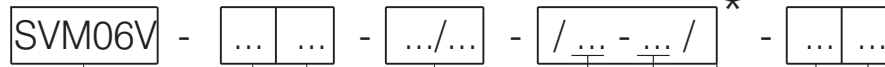

Stackable valve nominal size 06 (vertical stacking)

Number of section - up to 4

Modification of directional control valve:
 GF - **GF**
 GFM - **GFM**
 GFMS - **GFMS**
 see pages 35...37

Supply voltage/current frequency:
 see page 7
012/00
024/00
110/50
220/50

Stackable valves: repeat for each section
 first section - **A**
 second section - **B**
 third section - **C**
 fourth section - **D**

functional symbol of directional control valve
 see page 34

Cover:
 see page 44
 without cover - **Omit**
 series connection ("P"-blocked , "T"-passage) - **OCVS06**

Threads P , T , A & B ports:
 M14x1,5- **Omit**
 M16x1,5- **M1**
 G3/8"- **G1**
 G1/4"- **G2**

GENERAL DESCRIPTION

Flow automatically reverses direction from P-A to P-B when the setting value of pressure relief valves is reached.

- ✓ 4/2- way directional control valves with hydraulic pilot operation
- ✓ Manual override option
- ✓ Reliability and long life
- ✓ Mounting surface CETOP3 ; NG6

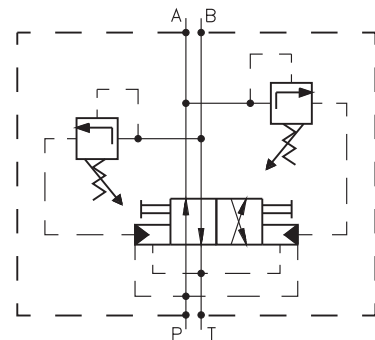
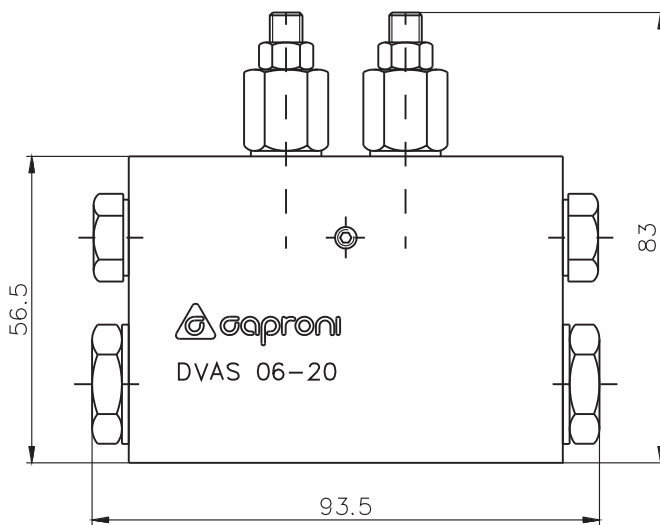
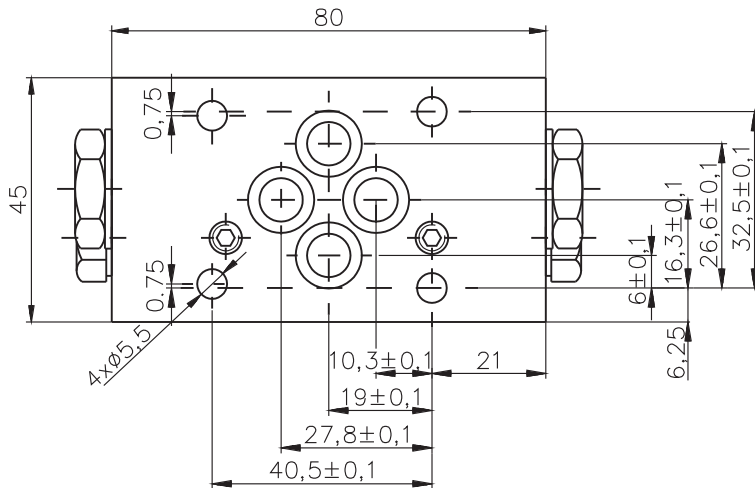
ORDERING CODE

DVAS 06 - 20 ...

Automatic switch directional control valve

Nominal size

Pressure range:

Omit- 50...200bar.

V1 - 0...100bar.

Direction of flow(symbol 20)

TECHNICAL DATA
GENERAL

DATA	UNIT	VALUE/RANGE
Installation position		preferably horizontal
Max. ambient temperature	°C	-20...+50
Weight	kg	1,400

HYDRAULIC

Max. pressure	MPa	21
Maximum flow	l/min	30
Minimum flow	l/min	4
Hydraulic fluid: -viscosity -filtration degree -temperature	mm ² /s mm °C	10...800 0.025 -20...80

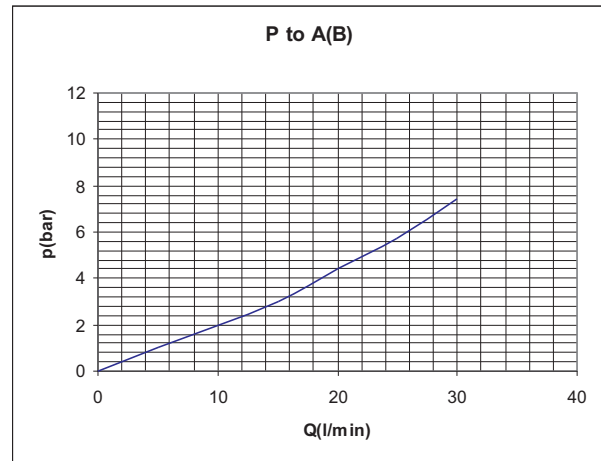
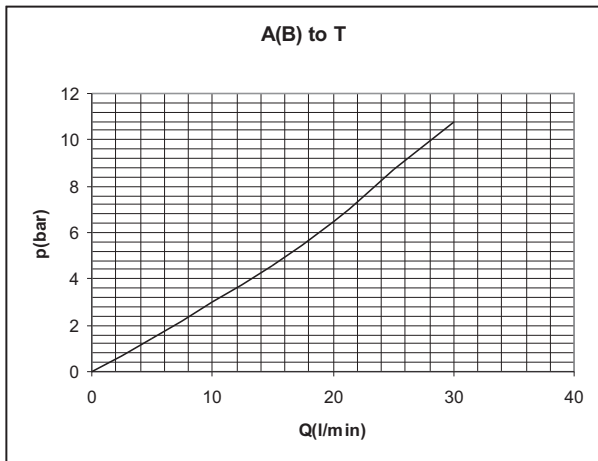
CHARACTERISTICS
 $\Delta p/Q$

APPENDIX

CONVERSION TABLE

Unit	≈	Factor	x	Unit
1 in	≈	25.4		mm
1 PSI	≈	0.07		bar
1 USGPM	≈	3.79		l/min
1 in ³	≈	16.66		cm ³
1 cSt	≈	1		mm ² /s
1 lbft	≈	1.347		Nm
5(°F-32)/9	≈	1		°C

ADDITIONAL INFORMATION

All specifications , descriptions and illustrations contained herein , refer to the products to the time of printing. "CAPRONI" reserves its right to discontinue models , modify or revise the specifications without notice. For the most current information contact our distributors or local office. Another functional symbols are possible in case of request.

May 2011



BULGARIA , 6100 KAZANLAK , 45 STOLETOV STR.
 TEL.:+359/431/62 229 , +359/431/6132 ,
 FAX:+359/431/62 230 , +359/431/63 134
 E-MAIL:CAPRONI@CAPRONI.BG , WEB:HTTP://WWW.CAPRONI.BG