



# M+S HYDRAULIC

## HEAVY DUTY MOTORS



SAE version

# HEAVY DUTY HYDRAULIC MOTORS

## CONTENTS

	Page
● Hydraulic Motors Series MLHSEM .....	4
● Hydraulic Motors Series MTK .....	8
● Hydraulic Motors Series MLHTM .....	17
● Hydraulic Motors Series TMF .....	29
● Hydraulic Motors Series MVM .....	34
● Hydraulic Motors Series MVMC .....	39
● Hydraulic Motors Series VMF .....	44
● Motor Special Features .....	48
● Motors with Speed Sensor .....	49
● Application Calculation .....	51

"M+S HYDRAULIC" can accept no responsibility for possible errors in catalogues, brochures and other printed material.

"M+S HYDRAULIC" reserves the right to alter its products without notice. This also applies to products already on order provided that such alterations can be made without subsequential changes being necessary in specifications already agreed.

# DISC VALVE HYDRAULIC MOTORS

---

## GENERAL INFORMATION:

---

Orbit motors convert hydraulic energy (pressure, oil flow) into mechanical energy (torque, speed). Hydraulic orbit motors operate on the principle of an internal gear (rotor) rotating within a fixed external gear (stator). The internal gear transmits the torque generated by the application of pressure from hydraulic oil fed into motor which is then delivered via the motor's output shaft. Orbit motors have high starting torque and constant output torque at wide speed range. The output shaft runs on tapered roller bearings and can absorb high axial and radial forces.

### DISTRIBUTOR VALVE

MLHSEM, MTK, MLHTM, TMF, MVM, MVMC, VMF series motors have disk valve: the distributor valve has been separated from output shaft and is driven by short cardan shaft. A balance plate counterbalances the hydraulic forces around the distributor valve. It gives the motors high efficiency- even at high pressures, and good starting characteristics.

### GEAR WHEEL SET

There are two forms of gear wheel set: Gerotor set have plain teeth and Roll-gerotor set with teeth fitted with rollers. MLHSEM, MTK, MLHTM, TMF, MVM, MVMC, VMF series motors have roll-gerotor set. The rollers reduce local stress and the tangential reaction forces on the rotor reducing friction to a minimum. This gives long operating life and better efficiency even at continuous high pressures.

## FEATURES:

---

### Standard Motor

The standard motor mounting flange is located as close to the output shaft as possible. This type of mounting supports the motor close to the shaft load. This mounting flange is also compatible with many standard gear boxes.

### Wheel Motor

The wheel motor mounting flange is located near the center of the motor which permits part or all of the motor to be located inside the wheel or roller hub. In traction drive applications, loads can be positioned over the motor bearings for best bearing life. This wheel motor mounting flange provides design flexibility in many applications.

### Short Motor

This motor is assembled without the output shaft, bearings and bearing housing and has the same drive components as the standard motors. The short motor is especially suited for applications such as gear boxes, winch, reel and roll drives. Short motor applications must be designed with a bearing supported internal spline to mate with the short motor drive. Product designs using these hydraulic motors provide considerable cost savings.

### Low Leakage

LL Series hydraulic motors are designed to operate at the whole standard range of working conditions (pressure drop and frequency of rotation), but with considerable decreased volumetric losses in the drain ports. This motors are suitable for hydraulic systems with series-connected motors with demands for low leakage.

### Low Speed Valve

LSV feature optimizes the motor for low-speed performance. Motors with this valving provide very low speed while maintaining high torque. They are designed to run continuously at low speed (up to 200 RPM) at normal pressure drop and reduced flow. Optimal run is guaranteed at frequency of rotation from 20 to 50 RPM. Motors with this valving have an increased starting pressure and are not recommended for using at pressure drop less than 580 PSI [40 bar].

### Motors with Speed Sensor

Motors are available with integrated inductive speed sensor. The output signal is a standardized voltage signal that can be used to control the speed of a motor. The torque and the radial load of the motor are not affected by the installation of speed sensor.

# HYDRAULIC MOTORS MLHSEM



## APPLICATION

- » Sawmill machines
- » Woodworking machines
- » Metal working machines
- » Agriculture machines
- » Road building machines
- » Mining machinery
- » Food industries
- » Special vehicles etc.

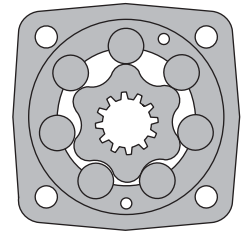
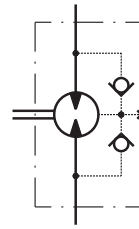

## CONTENTS

Specification data .....	5
Dimensions and mounting .....	6
Permissible shaft loads .....	6
Order code .....	7

## OPTIONS

- » Model- Disc valve, roll-gerotor
- » Wheel mount
- » Side ports
- » Shaft- tapered
- » SAE and Metric ports
- » Other special features

## GENERAL

<b>Max. Displacement,</b> in <sup>3</sup> /rev [cm <sup>3</sup> /rev]	397 [24.2]
<b>Max. Speed,</b> [RPM]	560
<b>Max. Torque,</b> lb-in [daNm]	cont.: 90 [7965] int: 110 [9735]
<b>Max. Output,</b> HP [kW]	24 [32.2]
<b>Max. Pressure Drop,</b> PSI [bar]	cont.: 200 [2900] int: 225 [3270]
<b>Max. Oil Flow,</b> GPM [lpm]	90 [24]
<b>Min. Speed,</b> [RPM]	5
<b>Pressure fluid</b>	Mineral based- HLP(DIN 51524) or HM(ISO 6743/4)
<b>Temperature range,</b> °F [°C]	-40÷140 [-40÷284]
<b>Optimal Viscosity range, SUS [mm<sup>2</sup>/s]</b>	20÷75 [98÷347]
<b>Filtration</b>	ISO code 20/16 (Min. recommended fluid filtration of 25 micron)

Oil flow in drain line

Pressure drop PSI [bar]	Viscosity SUS [mm <sup>2</sup> /s]	Oil flow in drain line GPM [lpm]
2030 [140]	98 [20]	.396 [1,5]
	164 [35]	.264 [1]
3045 [210]	98 [20]	.793 [3]
	164 [35]	.528 [2]

Pressure Losses

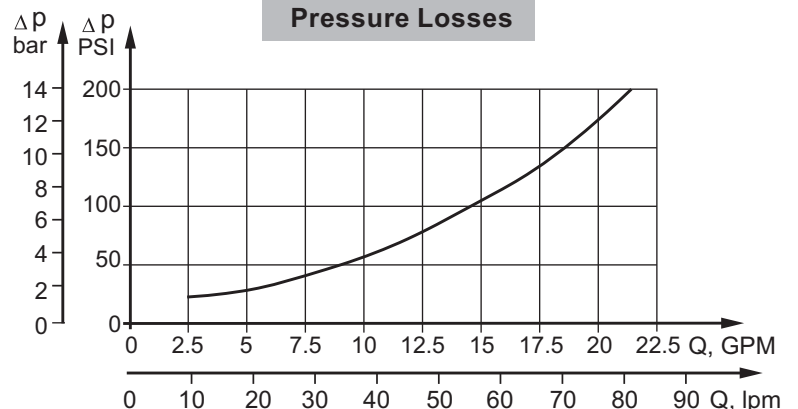

## SPECIFICATION DATA

Type	MLHSEM 160	MLHSEM 200	MLHSEM 250	MLHSEM 315	MLHSEM 400	
<b>Displacement, in<sup>3</sup>/rev [cm<sup>3</sup>/rev]</b>	9.74 [159,7]	12.2 [200]	15.3 [250]	314,9 [19,2]	24.2 [397]	
<b>Max. Speed, [RPM]</b>	cont.	470	375	300	240	185
	Int.*	560	450	360	285	225
<b>Max. Torque lb-in [daNm]</b>	cont.	4070 [46]	5010 [56,6]	6270 [70,8]	7965 [90,0]	7965 [90,0]
	Int.*	4560 [51,5]	5710 [64,5]	7135 [80,6]	8500 [96,0]	8585 [97,0]
	peak**	4560 [51,5]	5755 [65]	7135 [80,6]	9560 [108]	9735 [110]
<b>Max. Output HP [kW]</b>	cont.	24.9 [18,6]	24.3 [18,1]	24.1 [18,0]	22.8 [17,0]	14.7 [11,0]
	int.*	32.2 [24,0]	32.2 [24,0]	31.9 [23,8]	27.1 [20,2]	16.1 [12]
<b>Max. Pressure Drop PSI [bar]</b>	cont.	2900 [200]	2900 [200]	2900 [200]	2900 [200]	2320 [160]
	Int.*	3270 [225]	3270 [225]	3270 [225]	3190 [220]	2540 [175]
	peak**	3270 [225]	3270 [225]	3270 [225]	3270 [225]	2900 [200]
<b>Max. Oil Flow GPM [lpm]</b>	cont.	20 [75]	20 [75]	20 [75]	20 [75]	20 [75]
	Int.*	24 [90]	24 [90]	24 [90]	24 [90]	24 [90]
<b>Max. Inlet Pressure PSI [bar]</b>	cont.	3045 [210]	3045 [210]	3045 [210]	3045 [210]	3045 [210]
	Int.*	3625 [250]	3625 [250]	3625 [250]	3625 [250]	3625 [250]
	peak**	4350 [300]	4350 [300]	4350 [300]	4350 [300]	4350 [300]
<b>Max. Return Pressure with Drain Line PSI [bar]</b>	cont.	2030 [140]	2030 [140]	2030 [140]	2030 [140]	2030 [140]
	Int.*	2540 [175]	2540 [175]	2540 [175]	2540 [175]	2540 [175]
	peak**	3045 [210]	3045 [210]	3045 [210]	3045 [210]	3045 [210]
<b>Max. Starting Pressure with Unloaded Shaft, PSI [bar]</b>	145 [10]	145 [10]	145 [10]	145 [10]	145 [10]	
<b>Min. Starting Torque lb-in [daNm]</b>	3270 [36,9]	4090 [46,2]	5135 [58,0]	6530 [73,8]	6370 [72,0]	
<b>Min. Speed***, [RPM]</b>	6	6	6	5	5	

\* Intermittent operation: the permissible values may occur for max. 10% of every minute.

\*\* Peak load: the permissible values may occur for max. 1% of every minute.

\*\*\* For speeds lower than given, consult factory or your regional manager.

1. Intermittent speed and intermittent pressure must not occur simultaneously.
2. Recommended filtration is per ISO cleanliness code 20/16. A nominal filtration of 25 micron or better.
3. Recommend using a premium quality, anti-wear type mineral based hydraulic oil HLP(DIN51524) or HM ( ISO 6743/4).  
If using synthetic fluids consult the factory for alternative seal materials.
4. Recommended minimum oil viscosity 70 SUS [13 mm<sup>2</sup>/s] at 122°F [50°C].
5. Recommended maximum system operating temperature is 180°F [82°C].
6. To assure optimum motor life fill with fluid prior to loading and run at moderate load and speed for 10-15 minutes.

## DIMENSIONS AND MOUNTING DATA

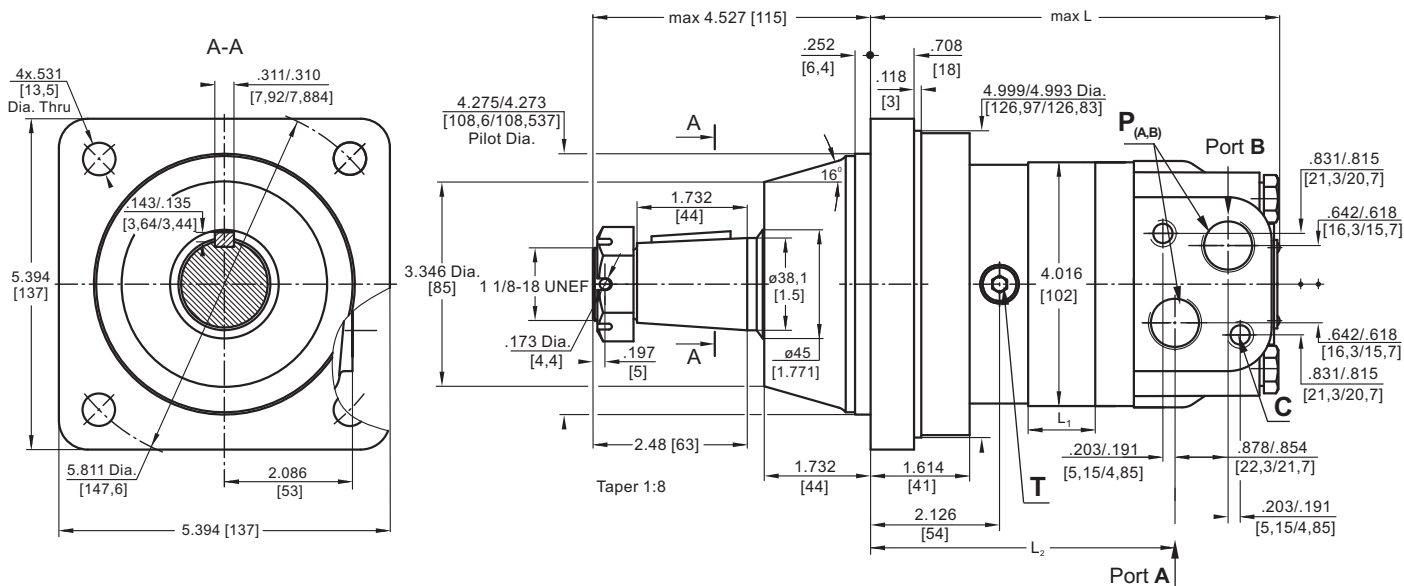

	Versions	
	2	4
<b>C</b>	2xM10	2x3/8-16UNC
<b>P(A,B)</b>	2xG1/2	2x7/8-14UNF
<b>T</b>	G1/4	7/16-20UNF

Type	L, in [mm]	L <sub>2</sub> , in [mm]	L <sub>1</sub> , in [mm]
MLHSEM 160	6.71 [170,5]	5.09 [129,3]	1.09 [27,8]
MLHSEM 200	6.99 [177,5]	5.37 [136,3]	1.37 [34,8]
MLHSEM 250	7.32 [186,0]	5.71 [145,0]	1.71 [43,5]
MLHSEM 315	7.78 [197,5]	6.19 [157,3]	2.16 [54,8]
MLHSEM 400	8.35 [212,0]	6.73 [171,0]	2.73 [69,4]

**Standard Rotation**  
 Viewed from Shaft End  
 Port A Pressurized - **CW**  
 Port B Pressurized - **CCW**

**Reverse Rotation**  
 Viewed from Shaft End  
 Port A Pressurized - **CCW**  
 Port B Pressurized - **CW**



## PERMISSIBLE SHAFT LOADS

The output shaft runs in tapered bearings that permit high axial and radial forces. Curve shows max. radial shaft load at bearing life of 2000 hours at 100 RPM.

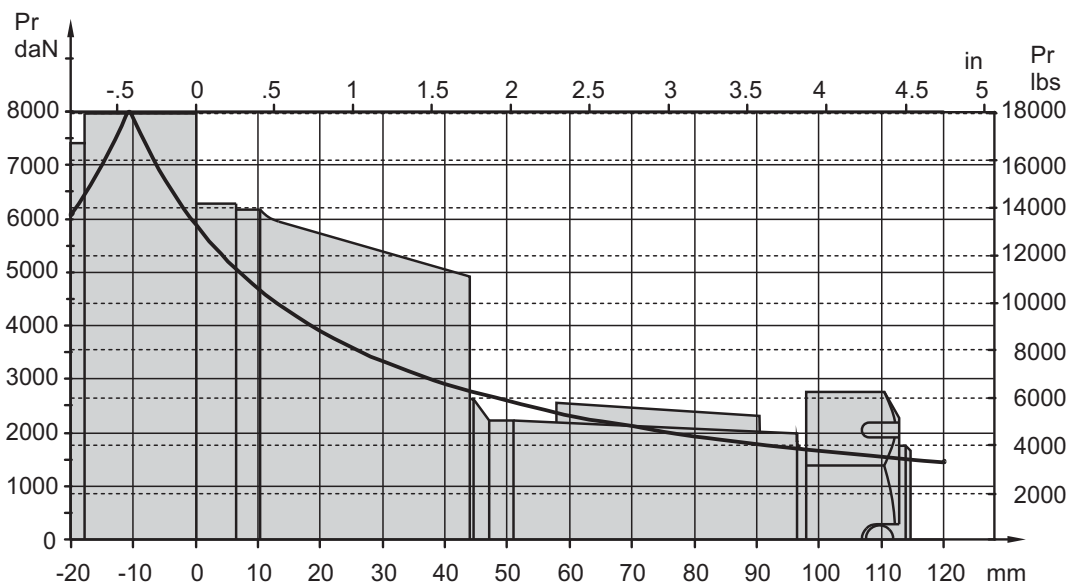

## ORDER CODE

	1	2	3	4	5
<b>M L H S E M</b>					

**Pos.1 - Displacement code**

<b>160</b>	- 9.74 in <sup>3</sup> /rev [159,7 cm <sup>3</sup> /rev]
<b>200</b>	- 12.20 in <sup>3</sup> /rev [200,0 cm <sup>3</sup> /rev]
<b>250</b>	- 15.30 in <sup>3</sup> /rev [250,0 cm <sup>3</sup> /rev]
<b>315</b>	- 19.20 in <sup>3</sup> /rev [314,9 cm <sup>3</sup> /rev]
<b>400</b>	- 24.20 in <sup>3</sup> /rev [397,0 cm <sup>3</sup> /rev]

**Pos.2 - Shaft Extensions**

**T** - 1½"[38,1] Tapered, Parallel key 5/16"x5/16"x1¼" BS46

**Pos.3 - Port Size/Type [standard manifold to each]**

<b>2</b>	- side ports, 2xG1/2, G1/4, BSP thread, ISO 228
<b>4</b>	- side ports, 2x7/8-14 UNF, O-ring, 7/16-20 UNF

**Pos.4 - Special Features [see page 48]**

**Pos.5 - Design Series**

omit - Factory specified

The hydraulic motors are mangano phosphatized as standard.

# HYDRAULIC MOTORS MTK



## APPLICATION

- » Conveyors
- » Metal working machines
- » Machines for agriculture
- » Road building machines
- » Mining machinery
- » Food industries
- » Special vehicles
- » Plastic and rubber machinery etc.

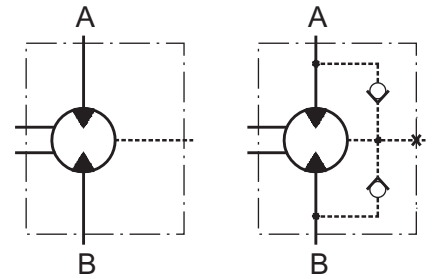

## CONTENTS

Specification data .....	9
Dimensions and mounting .....	10÷13
Shaft extensions .....	14
Permissible shaft loads .....	15
Order code .....	16

## OPTIONS

- » Model- Disc valve, roll-gerotor
- » Flange mount with wheel mount
- » Side and rear ports
- » Shafts- straight, splined and tapered
- » Metric, SAE and BSPP ports
- » Other special features

## GENERAL

<b>Displacement,</b>	in <sup>3</sup> /rev [cm <sup>3</sup> /rev]	9.63÷30.7 [157,9÷502,4]
<b>Max. Speed,</b>	RPM	159÷505
<b>Max. Torque,</b>	lb-in [daNm]	5045÷9650 [57÷109]
<b>Max. Output,</b>	HP [kW]	30 [22]
<b>Max. Pressure Drop,</b>	PSI [bar]	2320÷3626 [160÷250]
<b>Max. Oil Flow,</b>	GPM [lpm]	21 [80]
<b>Min. Speed,</b>	RPM	5÷10
<b>Permissible Shaft Loads,</b>	lb [daN]	Pa=2250 [1000]
<b>Pressure fluid</b>		Mineral based- HLP(DIN 51524) or HM(ISO 6743/4)
<b>Temperature range,</b>	°F [°C]	-22÷194 [-30÷90]
<b>Optimal Viscosity range, SUS [mm<sup>2</sup>/s]</b>		98÷347 [20÷75]
<b>Filtration</b>		ISO code 20/16 (Min. recommended fluid filtration of 25 micron)

### Oil flow in drain line

Pressure drop PSI [bar]	Viscosity SUS [mm <sup>2</sup> /s]	Oil flow in drain line GPM [lpm]
1450 [100]	98 [20]	.660 [2,5]
	164 [35]	.476 [1,8]
2030 [140]	98 [20]	.925 [3,5]
	164 [35]	.740 [2,8]

### Pressure Losses

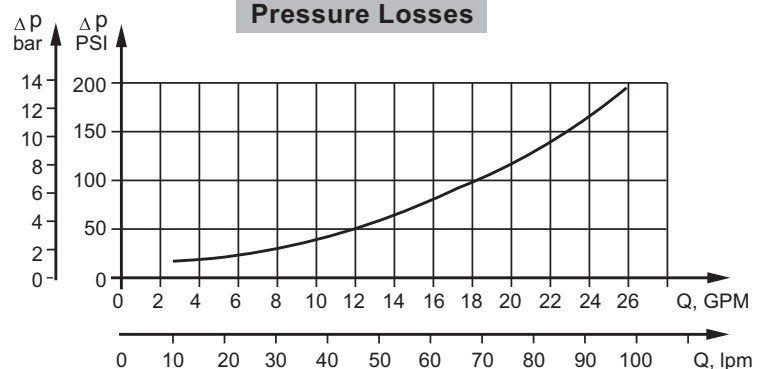



## SPECIFICATION DATA

Type	MTK 160	MTK 200	MTK 250	MTK 315	MTK 400	MTK 470	MTK 500	
<b>Displacement,</b> <b>in<sup>3</sup>/rev [cm<sup>3</sup>/rev]</b>	9.63 [157,9]	12.28 [201,3]	15.38 [252,2]	19.2 [314,9]	24.2 [396,8]	28.7 [470,5]	30.65 [502,4]	
<b>Max. Speed,</b> <b>[RPM]</b>	Cont.	505	400	320	255	200	170	159
	Int.*	630	500	400	315	250	210	199
<b>Max. Torque,</b> <b>lb-in [daNm]</b>	Cont.	5045 [57]	6373 [72]	8055 [91]	9293 [105]	9470 [107]	9028 [102]	9648 [109]
	Int.*	6420 [72,5]	8143 [92]	9470 [107]	11595 [131]	12390 [140]	11772 [133]	12037 [136]
<b>Max. Output,</b> <b>HP [kW]</b>	Cont.	29.5 [22]	29.5 [22]	28.2 [21]	26.8 [20]	23.5 [17,5]	18.8 [14]	18.8 [14]
	Int.*	36.2 [27]	36.2 [27]	33.5 [25]	31.5 [23,5]	29.5 [22]	23.5 [17,5]	22.8 [17]
<b>Max. Pressure Drop,</b> <b>PSI [bar]</b>	Cont.	3626 [250]	3626 [250]	3626 [250]	3626 [250]	2900 [200]	2320 [160]	2320 [160]
	Int.*	4714 [325]	4714 [325]	4350 [300]	4350 [300]	3626 [250]	2900 [200]	2900 [200]
<b>Max. Inlet Pressure,</b> <b>PSI [bar]</b>	Cont.	3626 [250]						
	Int.*	5077 [350]						
<b>Max. Oil Flow,</b> <b>GPM [lpm]</b>	Cont.	21.1 [80]						
	Int.*	26.4 [100]						
<b>Max. Starting Pressure with Unloaded Shaft, PSI [bar]</b>		116 [8]	116 [8]	102 [7]	102 [7]	102 [7]	102 [7]	102 [7]
<b>Min. Starting Torque,</b> <b>lb-in [daNm]</b>	at max. pressure drop cont.	3806 [43]	4780 [54]	6020 [68]	6992 [79]	7080 [80]	7346 [83]	7435 [84]
	at max. pressure drop int.*	4824 [54,5]	6107 [69]	7080 [80]	8720 [98,5]	9294 [105]	9294 [105]	9294 [105]
<b>Max. Return Pressure without Drain Line, PSI [bar]</b>		see diagram						
<b>Max. Return Pressure with Drain Line, PSI [bar]</b>	Cont.	2030 [140]						
	Int.*	2540 [175]						
	Peak*	3046 [210]						

\* Intermittent operation: the permissible values may occur for max. 10% of every minute.

\*\* Peak load: the permissible values may occur for max. 1% of every minute.

\*\*\* For speeds of 5 RPM lower than given, consult factory or your regional manager.

1. Intermittent speed and intermittent pressure must not occur simultaneously.
2. Recommended filtration is per ISO cleanliness code 20/16. A nominal filtration of 25 micron or better.
3. Recommend using a premium quality, anti-wear type mineral based hydraulic oil, HLP(DIN51524) or HM(ISO6743/4).  
If using synthetic fluids consult the factory for alternative seal materials.
4. Recommended minimum oil viscosity 70 SUS [13 cmi/s] at 122°F [50°C].
5. Recommended maximum system operating temperature is 180°F [82°C].
6. To assure optimum motor life fill with fluid prior to loading and run at moderate load and speed for 10-15 minutes.

**DIMENSIONS - MTK W and MTK C**

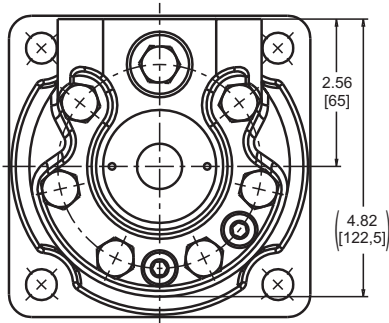
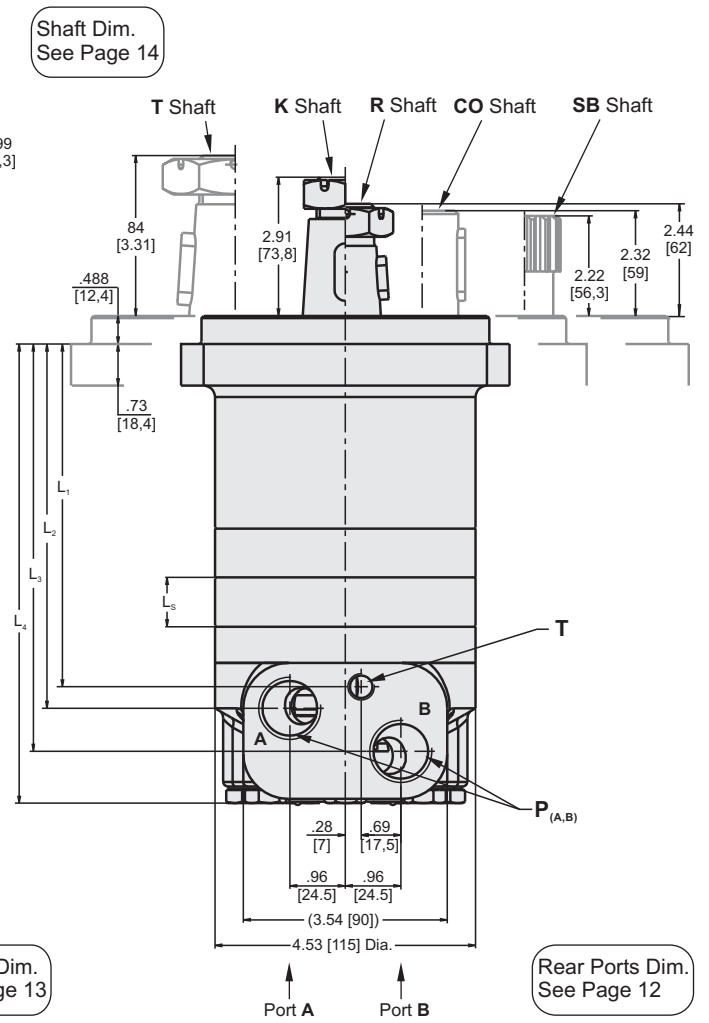
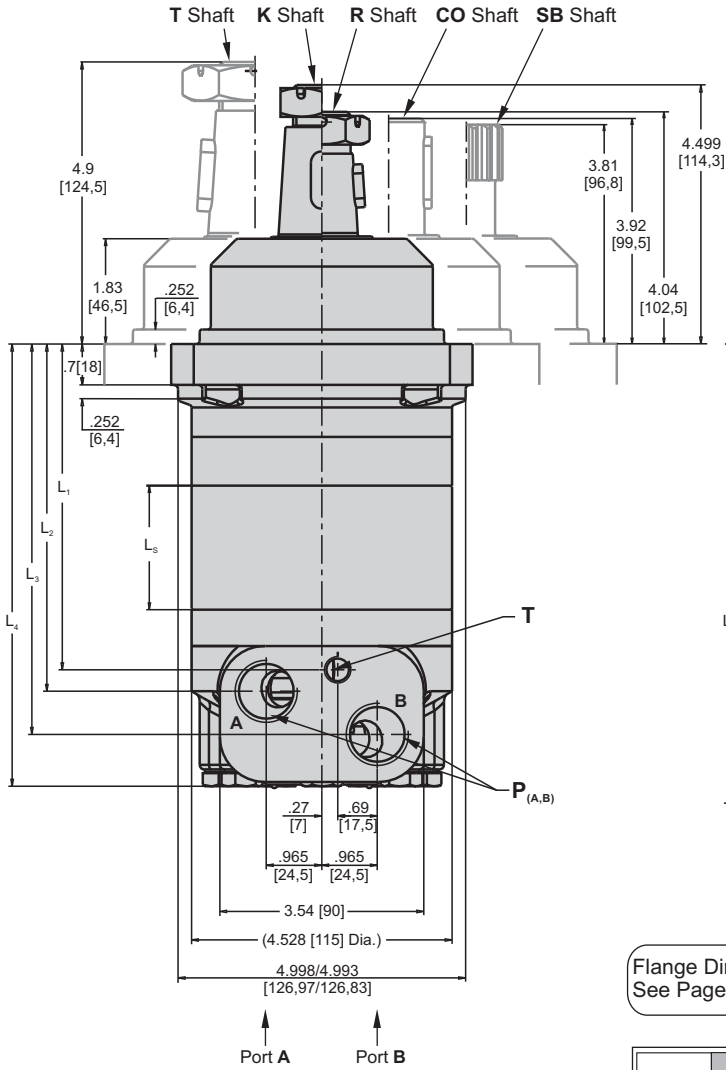

	Versions				
	Side			Rear	
	2	3	4	5	6
<b>P (A,B)</b>	2xG 3/4	2xM27x2	2x1 1/16-12UN	2xG 1/2	2x 7/8-20UNF
<b>T</b>	G 1/4	M14x1,5	7/16-20UNF	G 1/4	7/16-20UNF

Type	L <sub>s</sub> , in [mm]
MTKW160 MTKC160	.86 [21,8]
MTKW200 MTKC200	1.09 [27,8]
MTKW250 MTKC250	1.37 [34,8]
MTKW315 MTKC315	1.71 [43,5]
MTKW400 MTKC400	2.16 [54,8]
MTKW470 MTKC470	2.56 [65,0]
MTKW500 MTKC500	2.73 [69,4]



**Standard Rotation**  
Viewed from Shaft End  
Port A Pressurized - **CW**  
Port B Pressurized - **CCW**

**Reverse Rotation**  
Viewed from Shaft End  
Port A Pressurized - **CCW**  
Port B Pressurized - **CW**

Type	L <sub>1</sub> , in [mm]	L <sub>2</sub> , in [mm]	L <sub>3</sub> , in [mm]	L <sub>4</sub> , in [mm]	Type	L <sub>1</sub> , in [mm]	L <sub>2</sub> , in [mm]	L <sub>3</sub> , in [mm]	L <sub>4</sub> , in [mm]
MTKW160	4.36 [110,8]	4.74 [120,3]	5.48 [139,3]	6.39 [162,2]	MTKC160	5.96 [151,3]	6.33 [160,8]	7.08 [179,8]	7.98 [202,7]
MTKW200	4.59 [116,8]	4.97 [126,3]	5.72 [145,3]	6.62 [168,2]	MTKC200	6.19 [157,3]	6.57 [166,8]	7.32 [185,8]	8.22 [208,7]
MTKW250	4.87 [123,8]	5.25 [133,3]	5.99 [152,3]	6.89 [175,2]	MTKC250	6.47 [164,3]	6.84 [173,8]	7.59 [192,8]	8.49 [215,7]
MTKW315	5.22 [132,5]	5.59 [142,0]	6.34 [161,0]	7.24 [183,9]	MTKC315	6.81 [173,0]	7.19 [182,5]	7.93 [201,5]	8.84 [224,4]
MTKW400	5.66 [143,8]	6.04 [153,3]	6.78 [172,3]	7.69 [195,2]	MTKC400	7.26 [184,3]	7.63 [193,8]	8.38 [212,8]	9.28 [235,7]
MTKW470	6.06 [154,0]	6.44 [163,5]	7.19 [182,5]	8.09 [205,4]	MTKC470	7.66 [194,5]	8.03 [204,0]	8.78 [223,0]	9.68 [245,9]
MTKW500	6.24 [158,4]	6.61 [167,9]	7.36 [186,9]	8.26 [209,8]	MTKC500	7.83 [198,9]	8.20 [208,4]	8.95 [227,4]	9.85 [250,3]

**DIMENSIONS - MTK F**

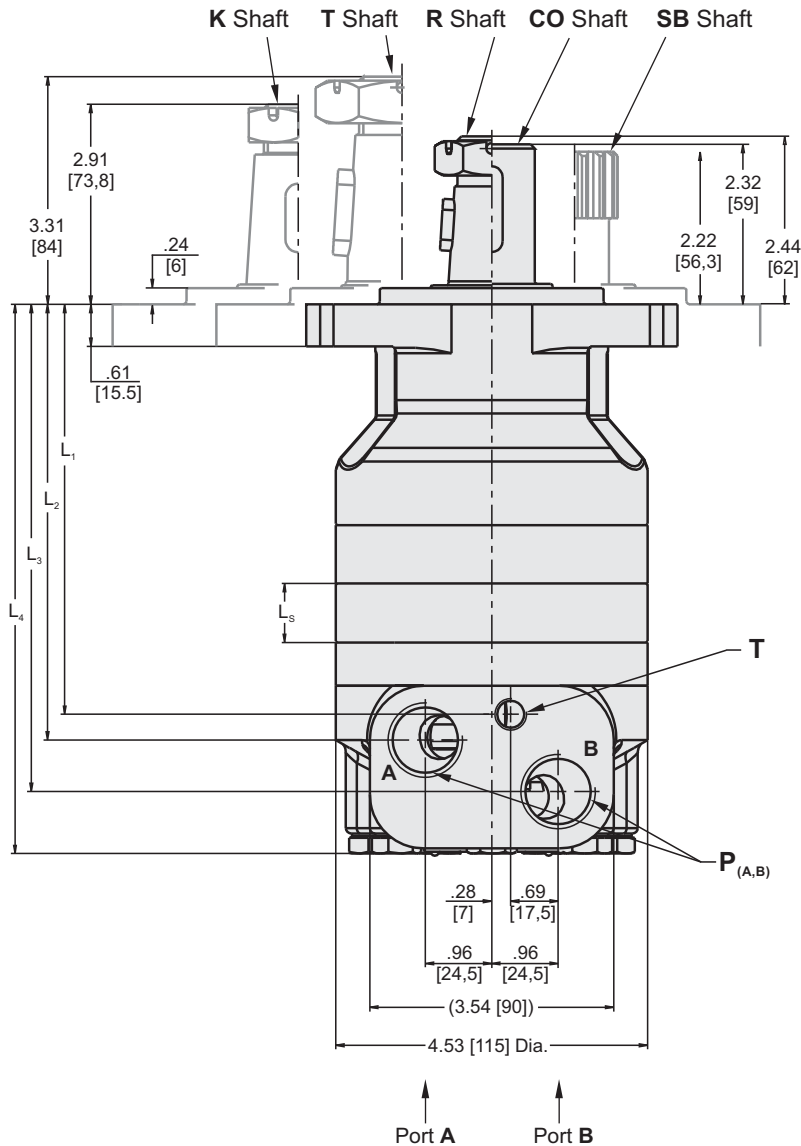

Shaft Dim.  
See Page 14

Flange Dim.  
See Page 13

Rear Ports Dim.  
See Page 12



**Standard Rotation**

Viewed from Shaft End  
Port **A** Pressurized - **CW**  
Port **B** Pressurized - **CCW**

**Reverse Rotation**

Viewed from Shaft End  
Port **A** Pressurized - **CCW**  
Port **B** Pressurized - **CW**

	Versions				
	Side			Rear	
	2	3	4	5	6
<b>P (A,B)</b>	2xG 3/4	2xM27x2	2x1 <sup>1</sup> / <sub>16</sub> -12UN	2xG 1/2	2x <sup>1</sup> / <sub>8</sub> -20UNF
<b>T</b>	G 1/4	M14x1,5	<sup>1</sup> / <sub>16</sub> -20UNF	G 1/4	<sup>1</sup> / <sub>16</sub> -20UNF

Type	L <sub>1</sub> , in [mm]	L <sub>2</sub> , in [mm]	L <sub>3</sub> , in [mm]	L <sub>4</sub> , in [mm]	L <sub>s</sub> , in [mm]
MTKF 160	5.96 [151,3]	6.33 [160,8]	7.08 [179,8]	7.98 [202,7]	.86 [21,8]
MTKF 200	6.19 [157,3]	6.57 [166,8]	7.32 [185,8]	8.22 [208,7]	1.09 [27,8]
MTKF 250	6.47 [164,3]	6.84 [173,8]	7.59 [192,8]	8.49 [215,7]	1.37 [34,8]
MTKF 315	6.81 [173,0]	7.19 [182,5]	7.93 [201,5]	8.84 [224,4]	1.71 [43,5]
MTKF 400	7.26 [184,3]	7.63 [193,8]	8.38 [212,8]	9.28 [235,7]	2.16 [54,8]
MTKF 470	7.66 [194,5]	8.03 [204,0]	8.78 [223,0]	9.68 [245,9]	2.56 [65,0]
MTKF 500	7.83 [198,9]	8.21 [208,4]	8.95 [227,4]	9.85 [250,3]	2.73 [69,4]

**Rear Ports**

**MTK W**

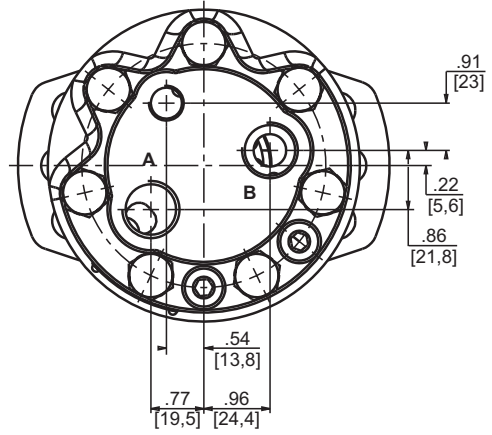
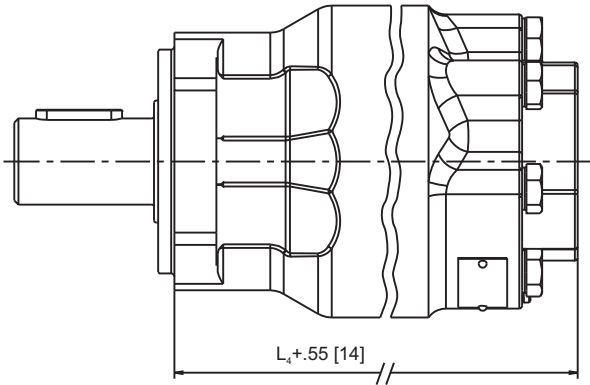

**MTK C**

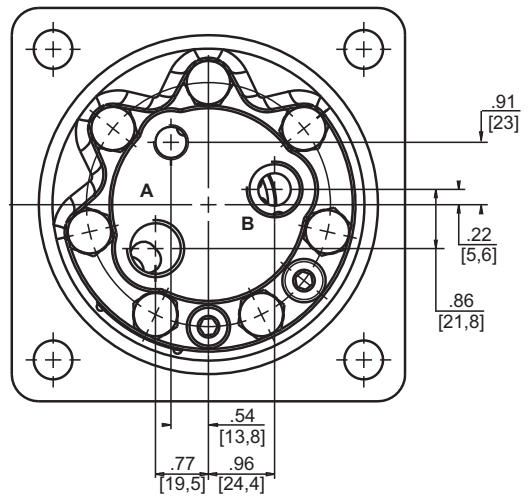
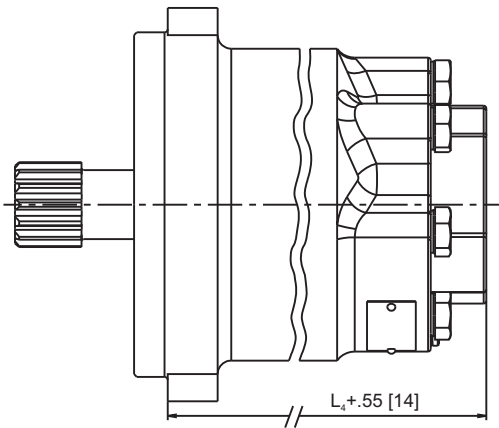

**MTK F**

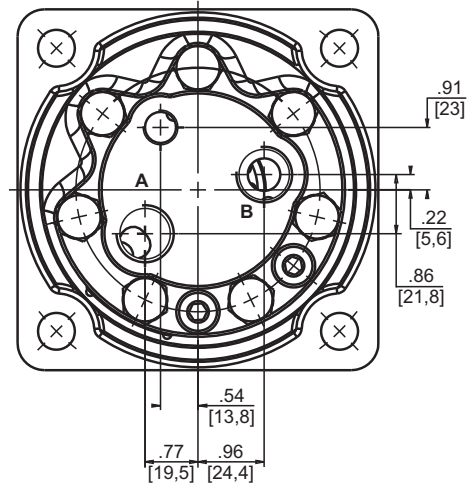
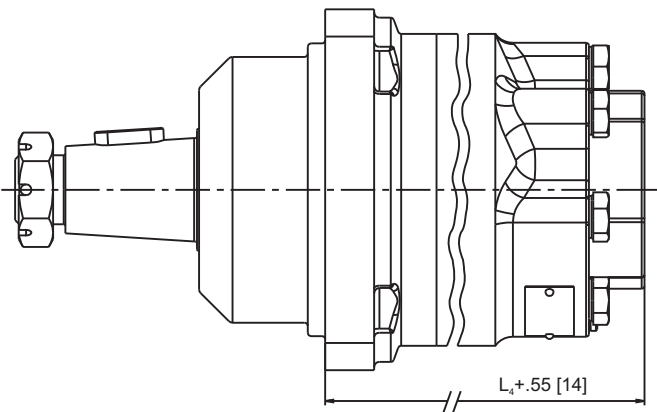

**DIMENSIONS OF MOUNTING**

**W** 4-Bolt flange, Wheel Motor  
spigot diameter 2.25 in [107,9 mm] - BC 5.81 in [147,6 mm]

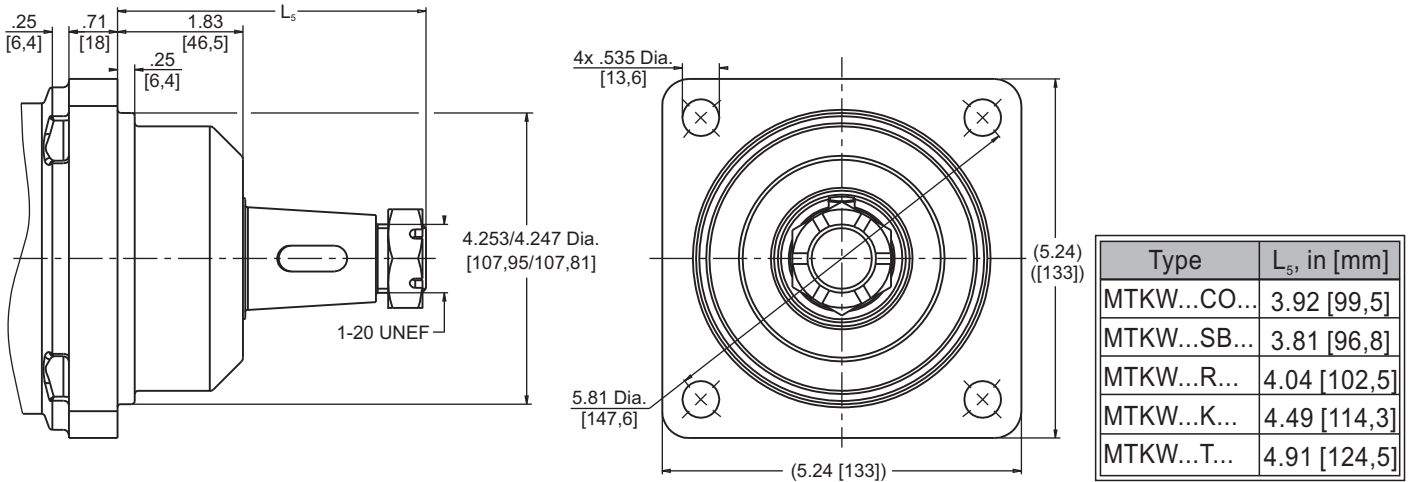

**C** 4-Bolt flange,  
spigot diameter 4.99 in [127 mm] - BC 6.375 in [161,92 mm]

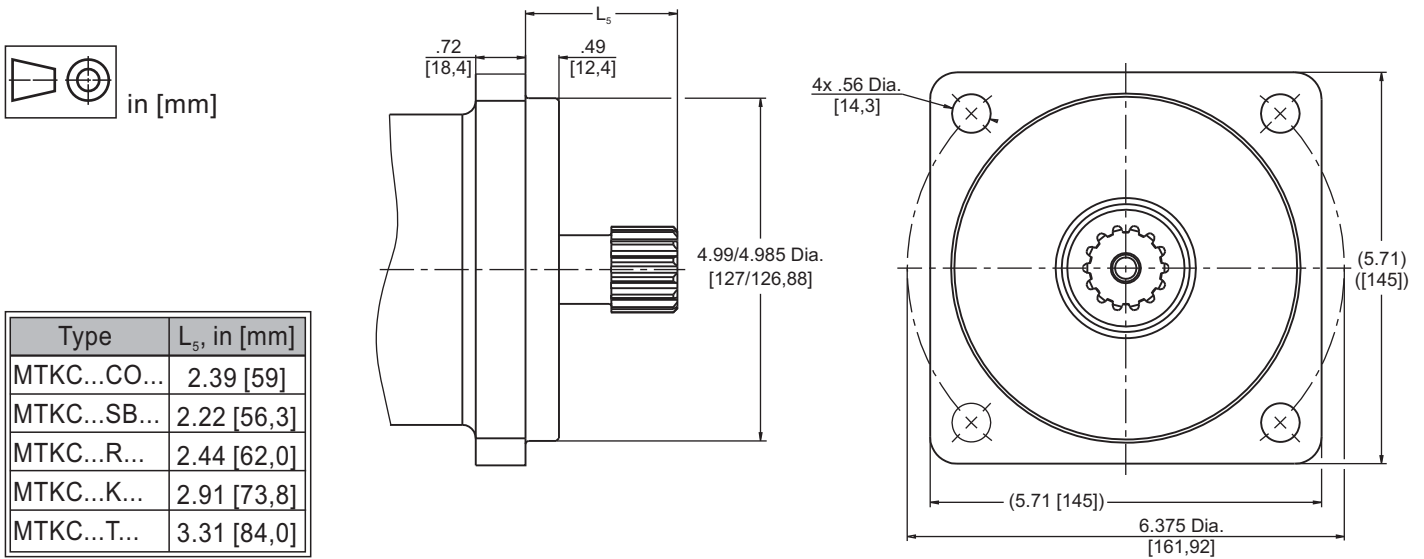

**F** 6-Bolt flange,  
spigot diameter 3.25 in [82,5 mm] - BC 4.19 in [106,35 mm]

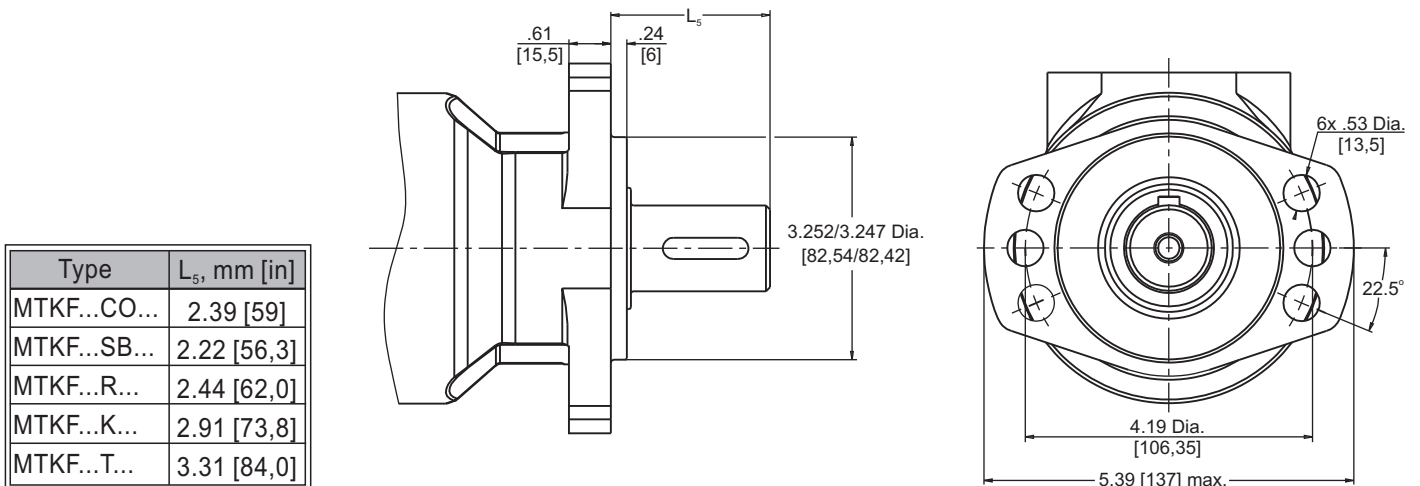

**SHAFT EXTENSIONS**

**CO**

ø1.25" [31,75] srtaight, Parallel key  $\frac{5}{16}$ "x $\frac{5}{16}$ "x $1\frac{1}{4}$ "  
Max. Torque 6815 lb-in [77 daNm]

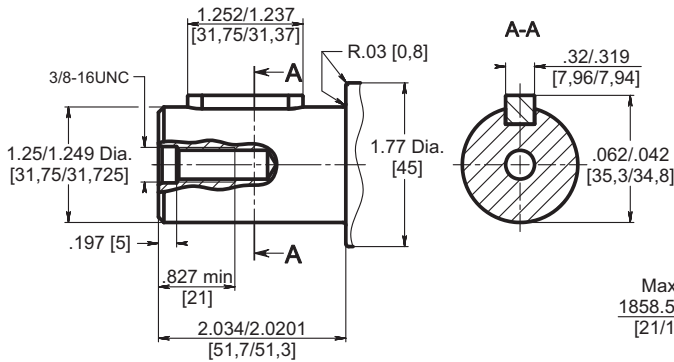

**R**

ø1.25" [31,75] tapered 1:8, Parallel key  $\frac{5}{16}$ "x $\frac{5}{16}$ "x $\frac{3}{4}$ "  
Max. Torque 6815 lb-in [77 daNm]

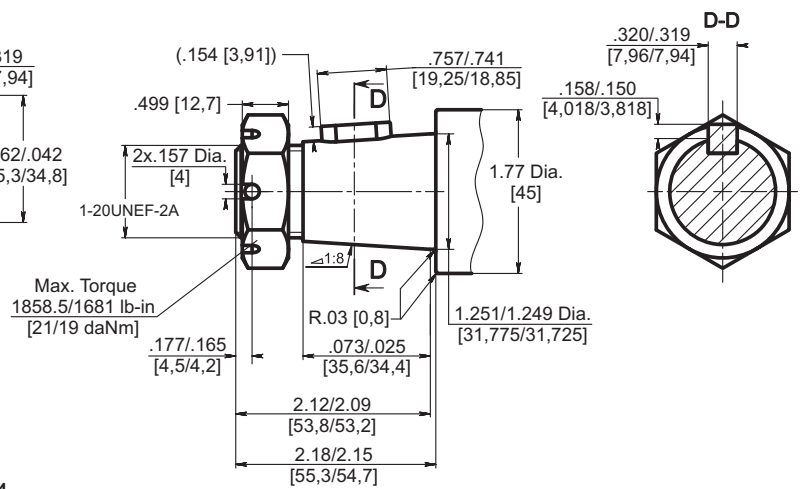

**SB**

ø1.25" [31,75] 14T Splined ANSI B92.1-1970, 12/24  
Max. Torque 6815 lb-in [77 daNm]

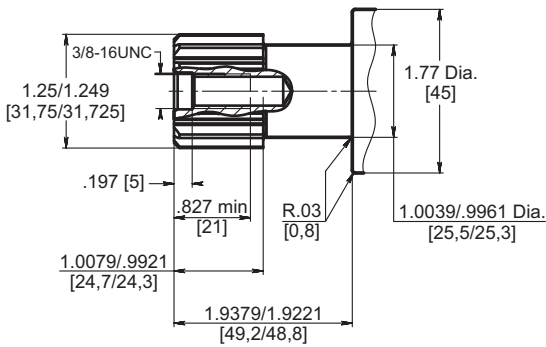

**K**

ø1.5" [38,1] tapered 1:8, Parallel key  $\frac{3}{8}$ "x $\frac{3}{8}$ "x1"  
Max. Torque 7878 lb-in [89 daNm]

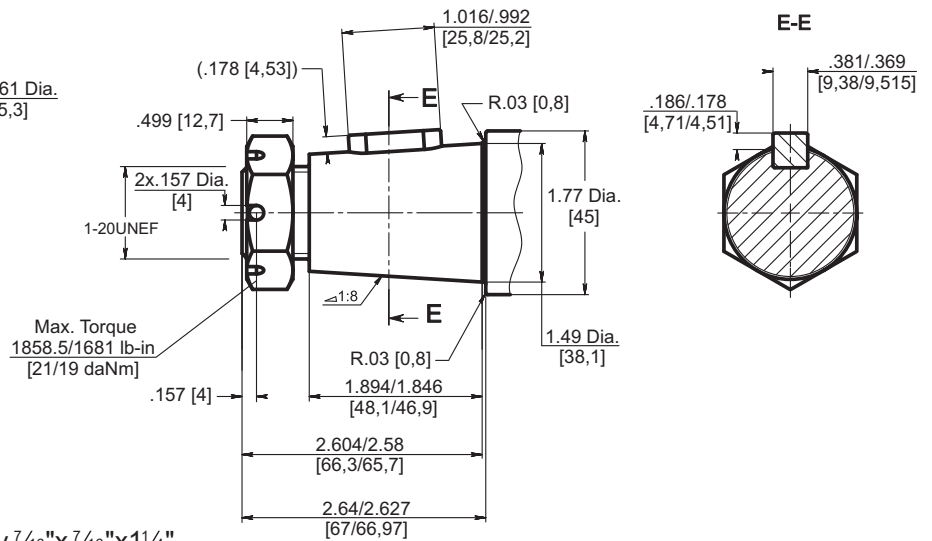

**T**

ø1.625" [41,275] tapered 1:8, Parallel key  $\frac{7}{16}$ "x $\frac{7}{16}$ "x $1\frac{1}{4}$ "  
Max. Torque 8850 lb-in [100 daNm]

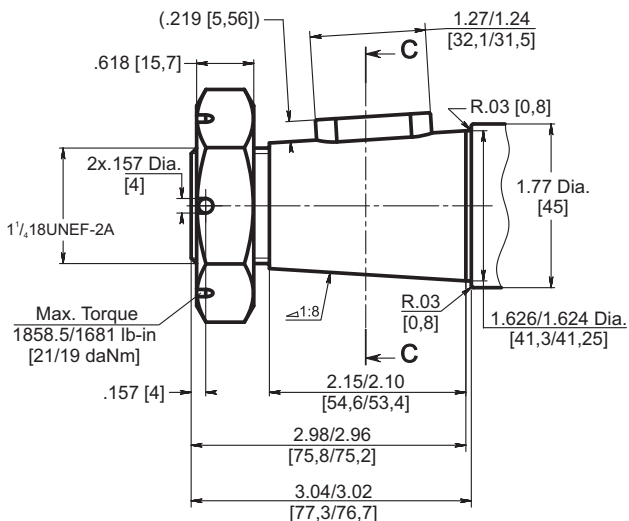

**C-C**

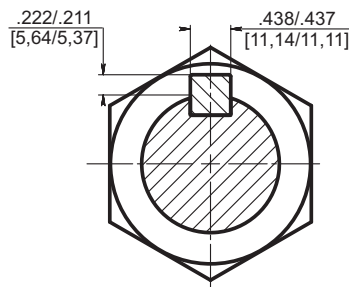

**PERMISSIBLE SHAFT LOADS**

The curves apply to a B10 bearing life (ISO281) of 2000 hours at 100 RPM.

**MTKF**

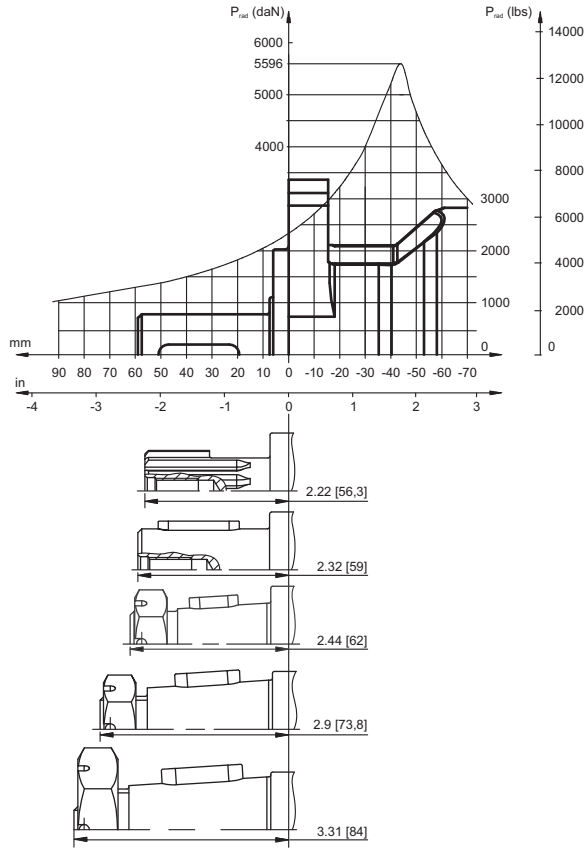

The curves apply to a B10 bearing life (ISO281) of 2000 hours at 100 RPM.

**MTKC**

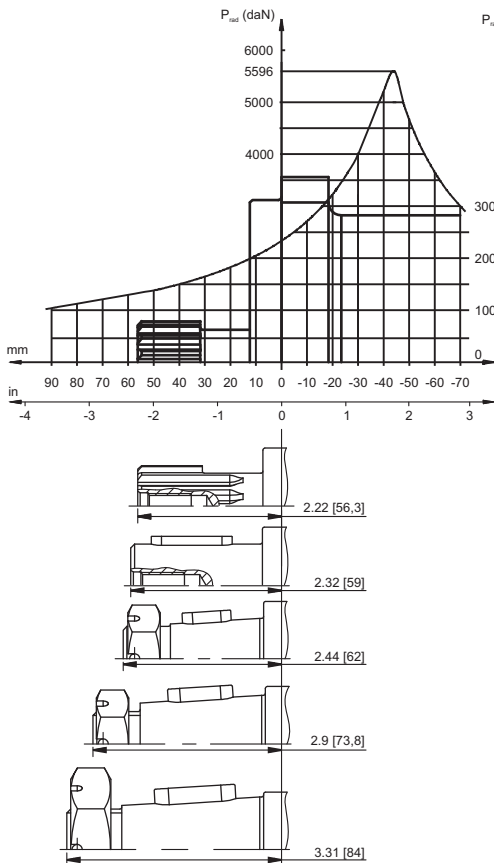

**MTKW**

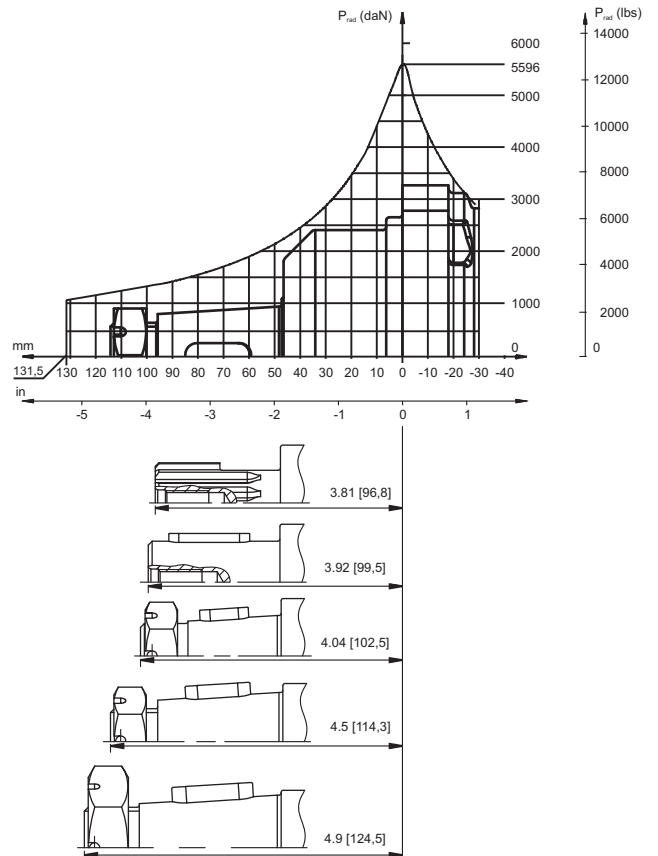

## MAX. PERMISSIBLE SHAFT SEAL PRESSURE for MTK motors

Max. return pressure without drain line or  
max. pressure in the drain line

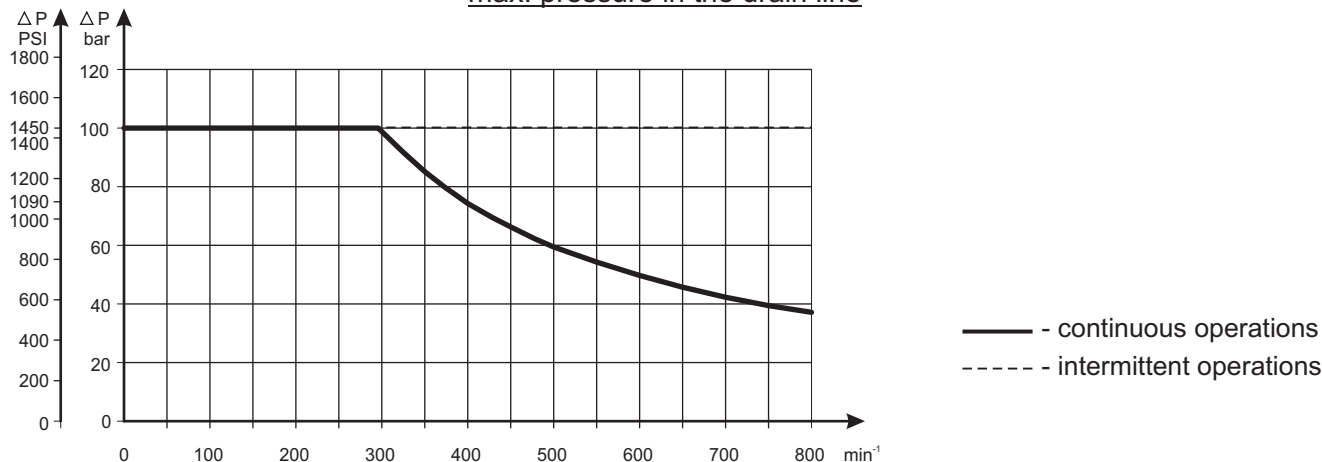

### ORDER CODE

	1	2	3	4	5	6	7	8
M T K								

#### Pos.1 - Mounting Flange

- W** - 4-Bolt flange, Wheel Motor spigot diameter 2.25 in [107,9 mm] - BC 5.81 in [147,6 mm]
- C** - 4-Bolt flange, spigot diameter 4.99 in [127 mm] - BC 6.375 in [161,92 mm]
- F** - Bolt flange, spigot diameter 3.25 in [82,5 mm] - BC 4.19 in [106,35 mm]

#### Pos.2 - Port type

- omit - Side ports
- E** - Rear ports

#### Pos.3 - Displacement code

- 160** - 9.63 in<sup>3</sup>/rev [157,9 cm<sup>3</sup>/rev]
- 200** - 12.28 in<sup>3</sup>/rev [201,3 cm<sup>3</sup>/rev]
- 250** - 15.38 in<sup>3</sup>/rev [252,2 cm<sup>3</sup>/rev]
- 315** - 19.20 in<sup>3</sup>/rev [314,9 cm<sup>3</sup>/rev]
- 400** - 24.20 in<sup>3</sup>/rev [396,8 cm<sup>3</sup>/rev]
- 470** - 28.70 in<sup>3</sup>/rev [470,5 cm<sup>3</sup>/rev]
- 500** - 30.65 in<sup>3</sup>/rev [502,4 cm<sup>3</sup>/rev]

#### Pos.4 - Shaft Extensions\*

- CO** - ø1.25" [31,75] straight, Parallel key 5/16"x5/16"x1 1/4", 3/8-16 UNC
- SB** - ø1.25" [31,75] 14T Splined ANSI B92.1-1970, 12/24, 3/8-16 UNC
- R** - ø1.25" [31,75] Tapered 1:8, Parallel key 5/16"x5/16"x3/4", 1-20 UNEF
- K** - ø1.5" [38,1] Tapered 1:8, Parallel key 3/8"x3/8"x1", 1-20 UNEF
- T** - ø1.625" [41,275] Tapered 1:8, Parallel key 7/16"x7/16"x1 1/4", 1 1/4-18 UNEF

#### Pos.5 - Port Size/Type

- 2** - side ports, 2xG 3/4, G1/4 BSP (ISO 228)
- 3** - side ports, 2xM27x2, M14x1,5 - 6H (ISO 262)
- 4** - side ports, 2x1 1/16-12 UN, 7/16-20 UNF
- 5** - rear ports, 2xG 1/2, G1/4 BSP (ISO 228)
- 6** - rear ports, 2x7/8-20 UNF, 7/16-20 UNF

#### Pos.6 - Check Valves

- omit - without check valves
- 1** - with check valves

#### Pos.7 - Special Features [see page 48]

- omit - Factory specified

#### Pos.8 - Design Series

- omit - Factory specified

Notes: \* The permissible output torque for shafts must be not exceeded!  
\*\* Color at customer's request.

The hydraulic motors are mangano phosphatized as standard.



# HYDRAULIC MOTORS MLHTM



## APPLICATION

- » Skid Steer Loaders
- » Metal working machines
- » Trenchers
- » Augers
- » Agriculture machines
- » Road building machines
- » Special vehicles
- » Mine machines
- » Woodworking and sawmill machinery
- » Conveyors etc.

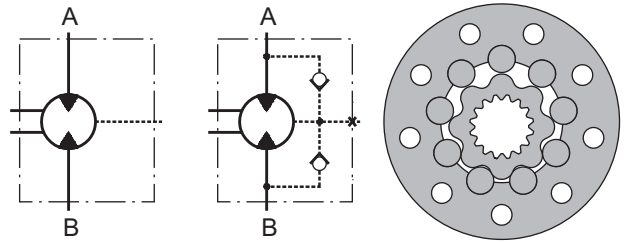

## CONTENTS

Specification data .....	18
Function diagrams .....	19÷21
Dimensions and mounting .....	22÷24
Shaft extensions .....	25
Permissible shaft loads .....	25
Dimensions and mounting- MLHTMV .....	26
Dimensions and mounting- MLHTM6V .....	27
Internal Spline data .....	28
Order code .....	28

## OPTIONS

- » Model- Disc valve, roll-gerotor
- » Flange with wheel mount
- » Short motor
- » Side ports
- » Shafts- straight, splined and tapered
- » SAE and BSPP ports;
- » Other special features.

## EXCELLENCE

- » High torque and pressure drop
- » High inlet pressure
- » High starting torque
- » Improved efficiency at high pressure drop
- » Smooth operation at low speed

## GENERAL

<b>Max. Displacement,</b> in <sup>3</sup> /rev [cm <sup>3</sup> /rev]	44.2 [724,3]
<b>Max. Speed,</b> [RPM]	750
<b>Max. Torque,</b> lb-in [daNm]	cont.: 16200 [183] int.: 20270 [229]
<b>Max. Output,</b> HP [kW]	94 [70]
<b>Max. Pressure Drop,</b> PSI [bar]	cont.: 3600 [250] int.: 5080 [350]
<b>Max. Oil Flow,</b> GPM [lpm]	40 [150]
<b>Min. Speed,</b> [RPM]	5
<b>Permissible Shaft Loads</b> lbs [daN]	P <sub>a</sub> =2250 [1000]
<b>Pressure fluid</b>	Mineral based- HLP(DIN 51524) or HM(ISO 6743/4)
<b>Temperature range,</b> °F [°C]	-40÷284 [-40÷140]
<b>Optimal Viscosity range, SUS [mm<sup>2</sup>/s]</b>	98÷347 [20÷75]
<b>Filtration</b>	ISO code 20/16 (Min. recommended fluid filtration of 25 micron)

### Oil flow in drain line

Pressure drop PSI [bar]	Viscosity SUS [mm <sup>2</sup> /s]	Oil flow in drain line GPM [lpm]
2900 [200]	98 [20]	.660 [2,5]
	164 [35]	.400 [1,5]
3990 [275]	98 [20]	1.057 [4]
	164 [35]	.660 [2,5]

### Pressure Losses

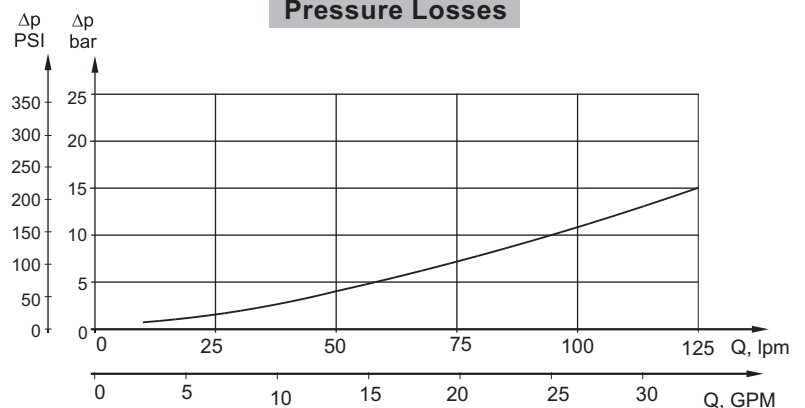

## SPECIFICATION DATA

Type		MLHTM 200	MLHTM 250	MLHTM 315	MLHTM 400	MLHTM 470	MLHTM 500	MLHTM 630	MLHTM 725
<b>Displacement, in<sup>3</sup>/rev [cm<sup>3</sup>/rev]</b>		12.29 [201,4]	15.36 [251,8]	19.9 [326,3]	25.06 [410,9]	28.97 [475]	31.95 [523,6]	38.52 [631,2]	44.2 [724]
<b>Max. Speed, [RPM]</b>	Cont.	625	500	380	305	260	240	190	170
	Int.*	750	600	460	365	315	285	230	215
<b>Max. Torque lb-in [daNm]</b>	Cont.	6375 [72]	7965[90]	10265[116]	13010[147]	15135[171]	15225[172]	16200[183]	14160[160]
	Int.*	9030[102]	11330[128]	14425[163]	18232[206]	16030[215]	19030[215]	20270[229]	17000[192]
	Peak**	10180[115]	12745[144]	16460[186]	20800[235]	21240[240]	21240[240]	24250[274]	21240[240]
<b>Max. Output HP [kW]</b>	Cont.	55 [41]	55 [41]	55 [41]	55 [41]	55 [41]	50[37,5]	37,5 [28]	35 [26]
	Int.*	87 [65]	94[70]	94[70]	94[70]	74[55]	68 [51]	56 [42]	54 [40]
<b>Max. Pressure Drop PSI [bar]</b>	Cont.	3600[250]	3600[250]	3600[250]	3600[250]	3600[250]	3340[230]	2900[200]	2320[160]
	Int.*	5080[350]	5080[350]	5080[350]	5080[350]	4570[315]	4060[280]	3625[250]	3045[210]
	Peak**	5800[400]	5800[400]	5800[400]	5800[400]	5080[350]	4640[320]	4350[300]	3770[260]
<b>Max. Oil Flow GPM [lpm]</b>	Cont.	33[125]	33[125]	33[125]	33[125]	33[125]	33[125]	33[125]	33[125]
	Int.*	40[150]	40[150]	40[150]	40[150]	40[150]	40[150]	40[150]	40[150]
<b>Max. Inlet Pressure PSI [bar]</b>	Cont.	3920[270]	3920[270]	3920[270]	3920[270]	3920[270]	3920[270]	3920[270]	3920[270]
	Int.*	5370[370]	5370[370]	5370[370]	5370[370]	5370[370]	5370[370]	5370[370]	5370[370]
	Peak**	6100[420]	6100[420]	6100[420]	6100[420]	6100[420]	6100[420]	6100[420]	6100[420]
<b>Max. Return Pressure without Drain Line or Max. Pressure in Drain Line, PSI [bar]</b>	Cont. 0-100 RPM	1100 [75]	1100 [75]	1100 [75]	1100 [75]	1100 [75]	1100 [75]	1100 [75]	1100 [75]
	Cont. 100-300 RPM	580 [40]	580 [40]	580 [40]	580 [40]	580 [40]	580 [40]	580 [40]	580 [40]
	Cont. >300 RPM	290 [20]	290 [20]	290 [20]	290 [20]	290 [20]	-	-	-
	Int.* 0-max. RPM	1100 [75]	1100 [75]	1100 [75]	1100 [75]	1100 [75]	1100 [75]	1100 [75]	1100 [75]
<b>Max. Return Pressure with Drain Line PSI [bar]</b>	Cont.	3920[270]	3920[270]	3920[270]	3920[270]	3920[270]	3920[270]	3920[270]	3920[270]
	Int.*	5370[370]	5370[370]	5370[370]	5370[370]	5370[370]	5370[370]	5370[370]	5370[370]
	Peak**	6100[420]	6100[420]	6100[420]	6100[420]	6100[420]	6100[420]	6100[420]	6100[420]
<b>Max. Starting Pressure with Unloaded Shaft, PSI [bar]</b>		90 [6]	90 [6]	90 [6]	90 [6]	90 [6]	90 [6]	90 [6]	90 [6]
<b>Min. Starting Torque lb-in [daNm]</b>		5310[60]	6640[75]	8585[97]	10800[122]	12570[142]	12655[143]	12830[145]	13100[148]
<b>Min. Speed***, [RPM]</b>		5	5	5	5	5	5	5	5
<b>Weight, lb [kg]</b>	MLHTM	59.3 [26,9]	60.2 [27,3]	62 [28,1]	64 [29]	65.5 [29,7]	66.6 [30,2]	65.5 [29,7]	68.4 [31]
	MLHTMW	60.4 [27,4]	61.3 [27,8]	63.1 [28,6]	65.1 [29,5]	66.6 [30,2]	67.7 [30,7]	66.6 [30,2]	69.5 [31,5]
	MLHTMV	34.6 [15,7]	35.5 [16,1]	37.3 [16,9]	39.3 [17,8]	40.8 [18,5]	41.9 [19]	40.8 [18,5]	43.7 [19,8]

\* Intermittent operation: the permissible values may occur for max. 10% of every minute.

\*\* Peak load: the permissible values may occur for max. 1% of every minute.

\*\*\* For speeds lower than given, consult factory or your regional manager.

- Intermittent speed and intermittent pressure drop must not occur simultaneously.
- Recommended filtration is per ISO cleanliness code 20/16. A nominal filtration of 25 micron or better.
- Recommend using a premium quality, anti-wear type mineral based hydraulic oil HLP(DIN51524) or HM (ISO 6743/4).  
If using synthetic fluids consult the factory for alternative seal materials.
- Recommended minimum oil viscosity 70 SUS [13 mm<sup>2</sup>/s] at 122°F [50°C].
- Recommended maximum system operating temperature is 180°F [82°C].
- To assure optimum motor life fill with fluid prior to loading and run at moderate load and speed for 10-15 minutes.

## FUNCTION DIAGRAMS

### MLHTM 250

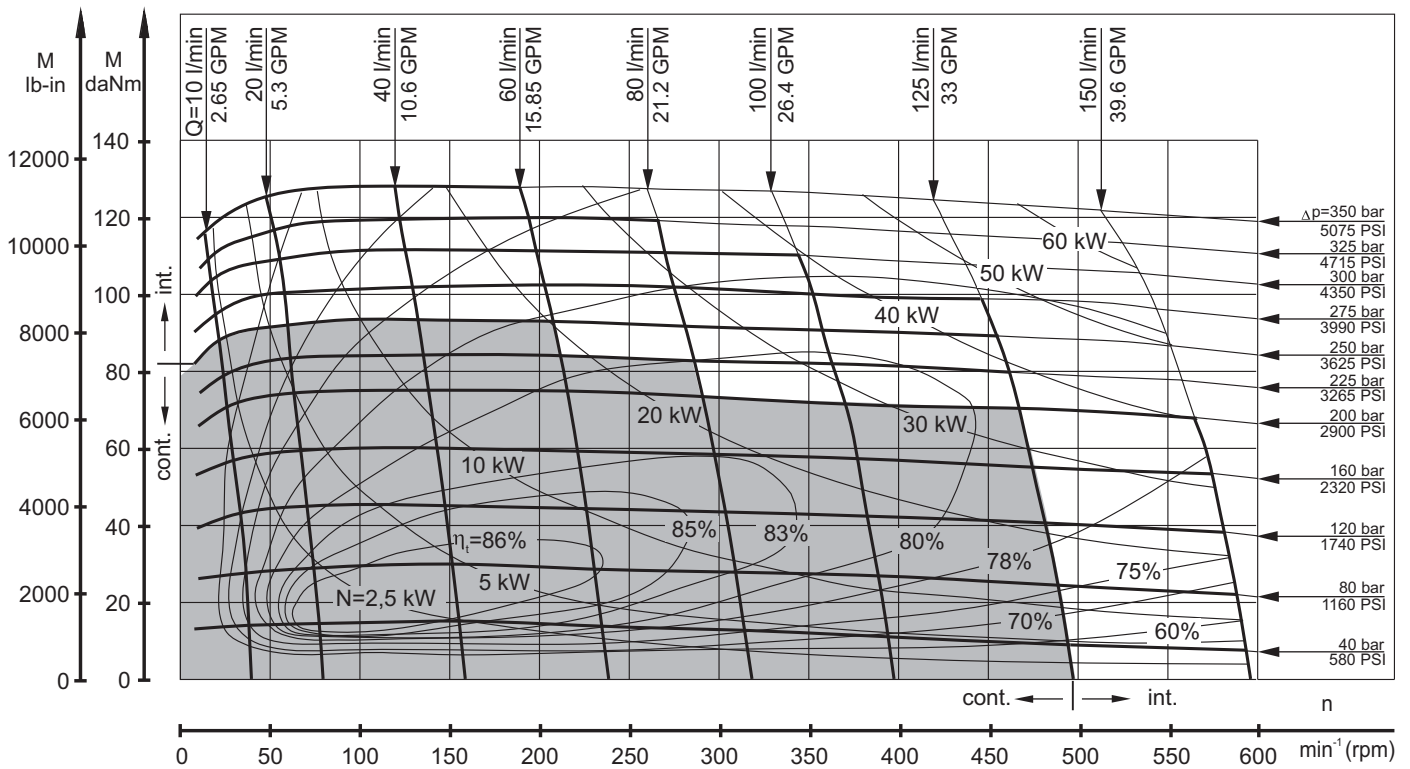

### MLHTM 315

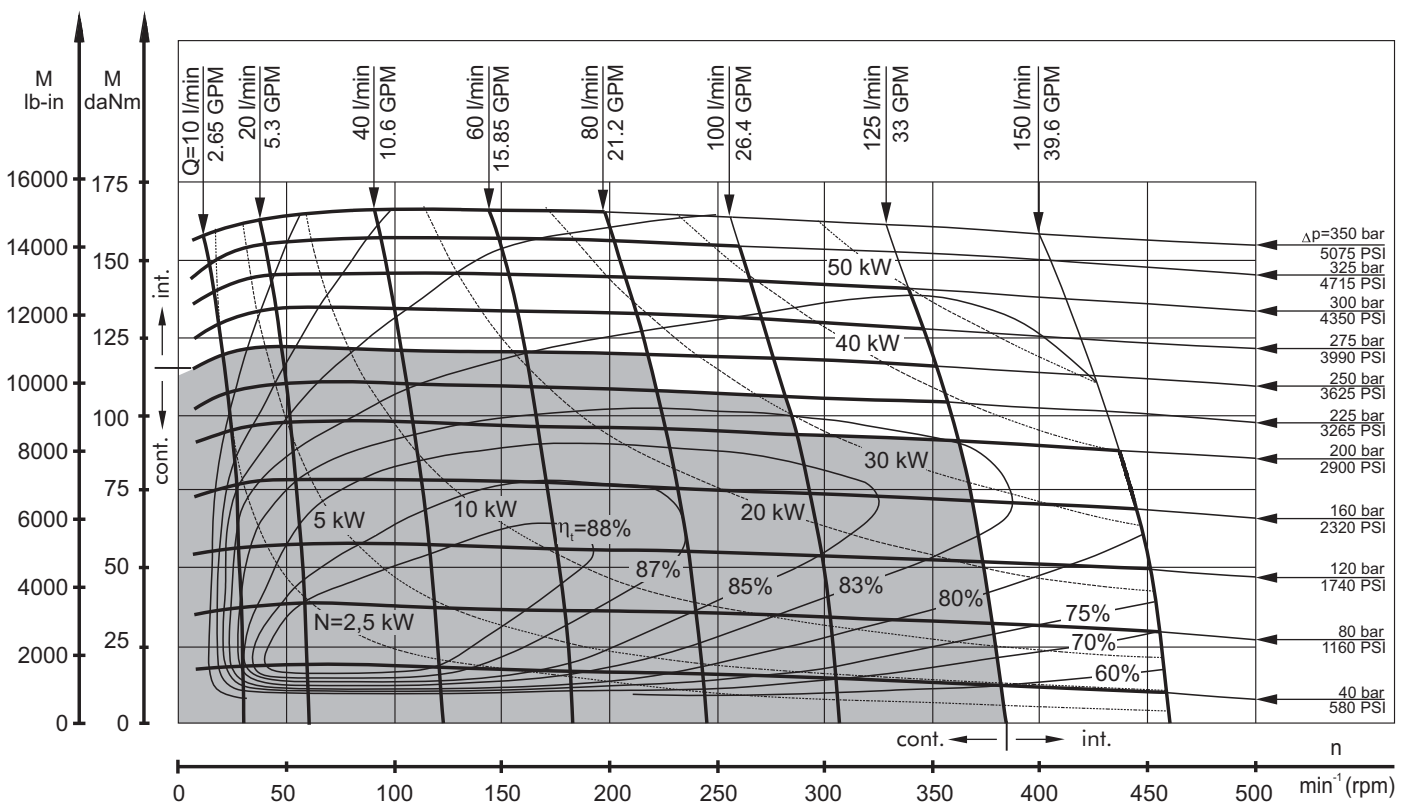

The function diagrams data is for average performance of randomly selected motors at back pressure 72.5÷145 PSI [5÷10 bar] and oil with viscosity of 150 SUS [32 mm<sup>2</sup>/s] at 122°F [50°C].

**FUNCTION DIAGRAMS**

**MLHTM 400**

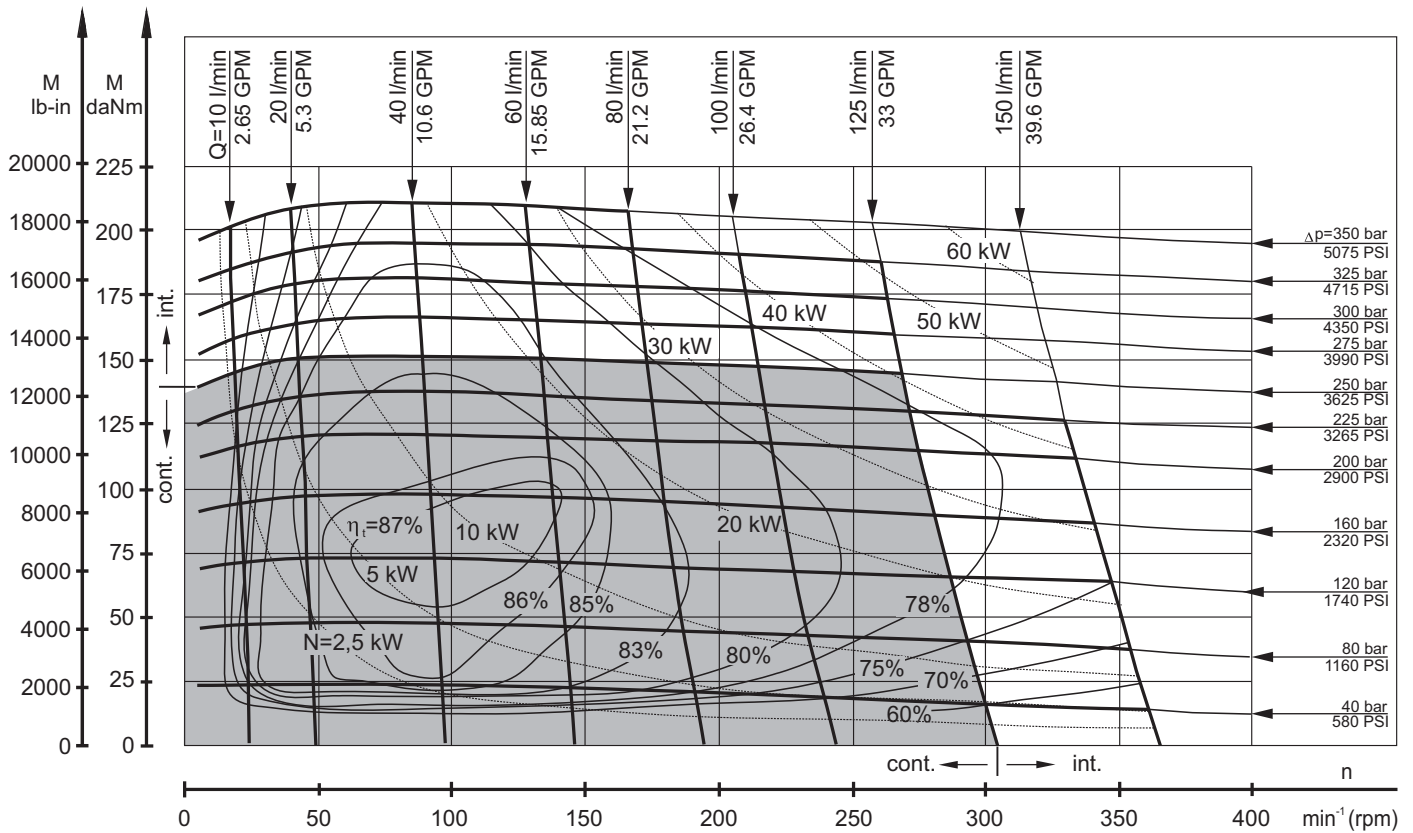

**MLHTM 470**

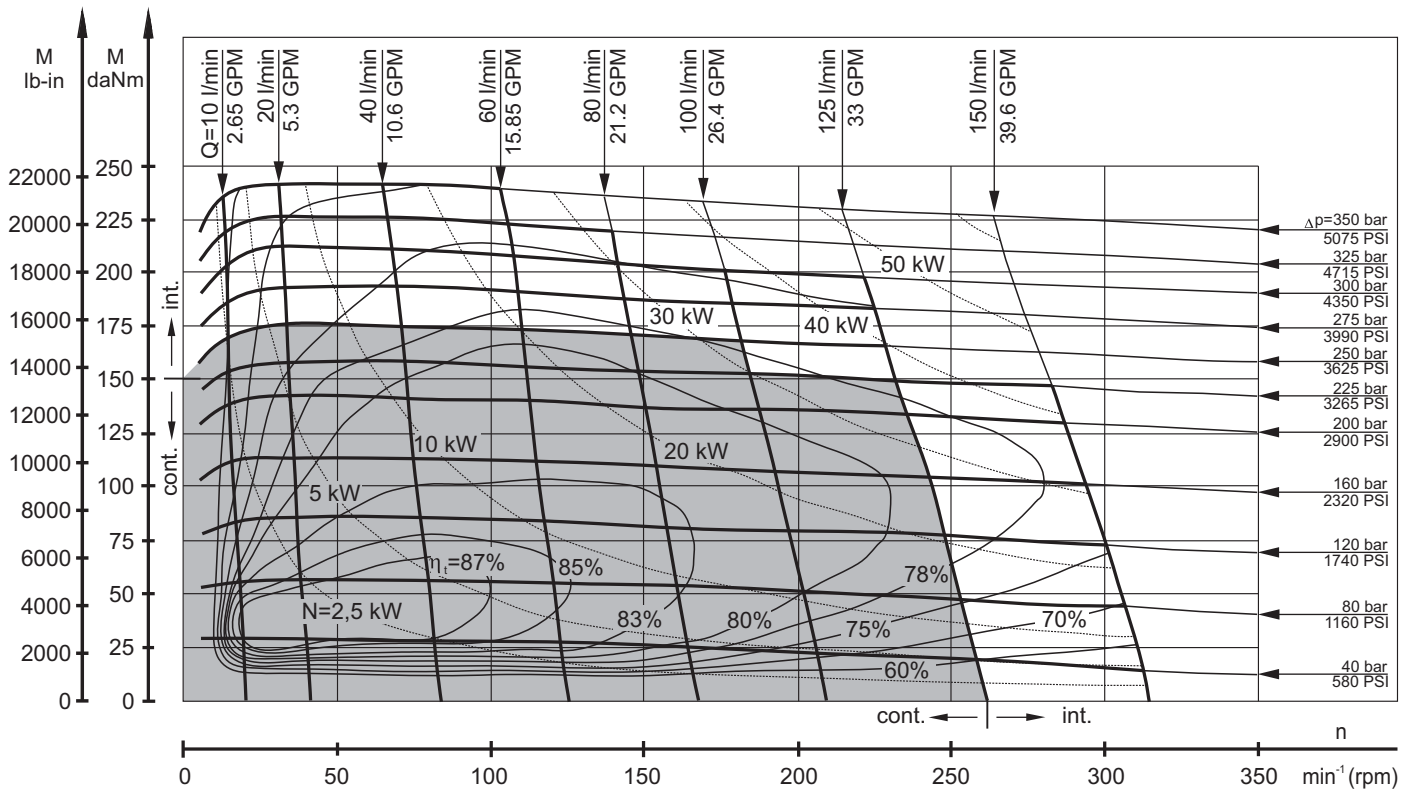

The function diagrams data is for average performance of randomly selected motors at back pressure 72.5÷145 PSI [5÷10 bar] and oil with viscosity of 150 SUS [32 mm<sup>2</sup>/s] at 122°F [50°C].

## FUNCTION DIAGRAMS

### MLHTM 500

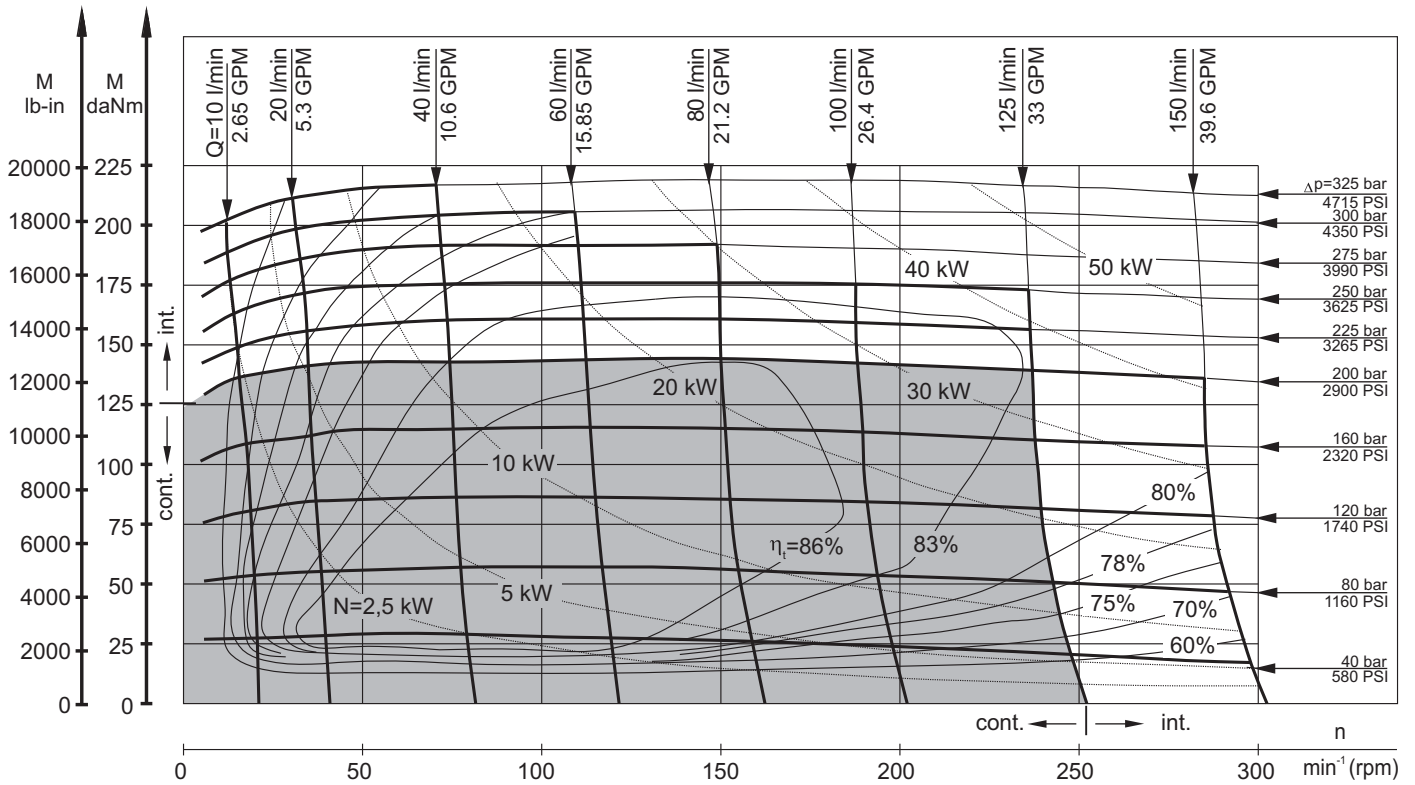

### MLHTM 630

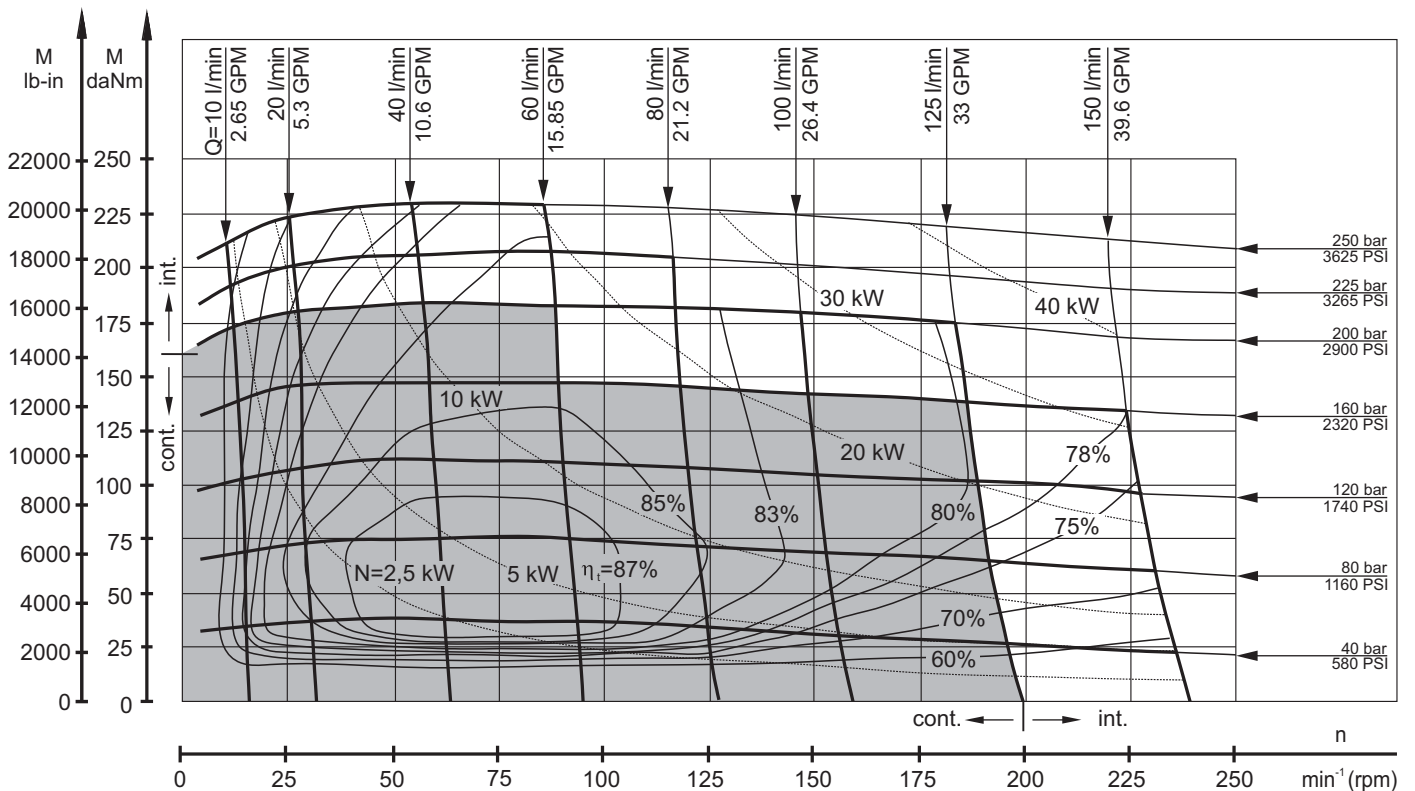

The function diagrams data is for average performance of randomly selected motors at back pressure 72.5÷145 PSI [5÷10 bar] and oil with viscosity of 150 SUS [32 mm<sup>2</sup>/s] at 122°F [50°C].

### DIMENSIONS -MLHTM and MLHTMC

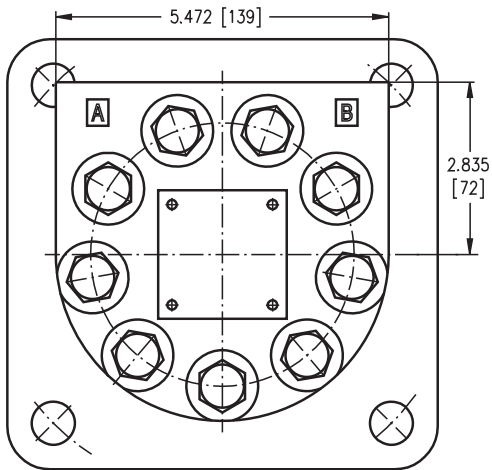
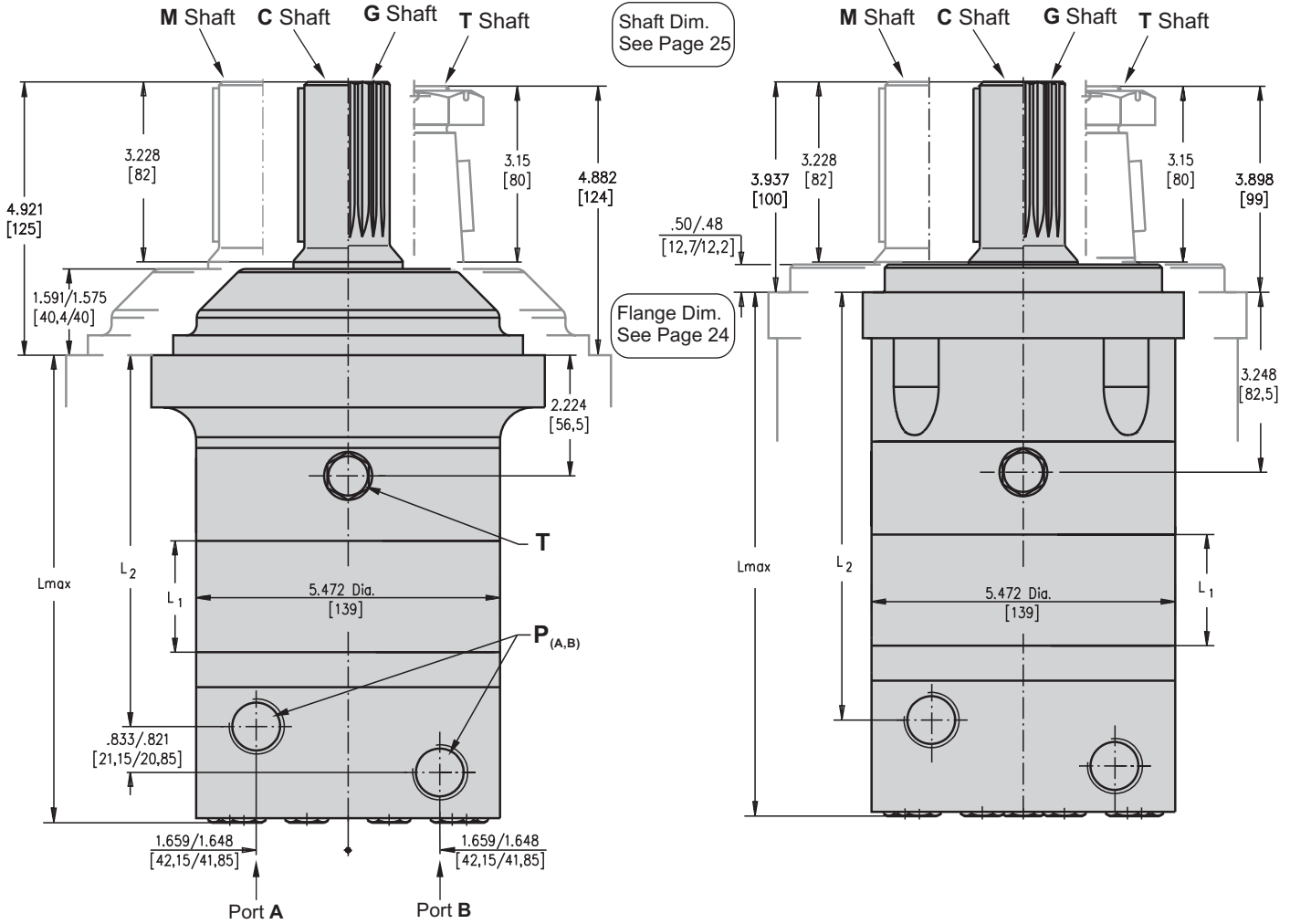

**Standard Rotation**  
Viewed from Shaft End  
Port A Pressurized - CW  
Port B Pressurized - CCW

**Reverse Rotation**  
Viewed from Shaft End  
Port A Pressurized - CCW  
Port B Pressurized - CW

	Versions	
	2	4
P (A,B)	2xG 3/4	2x1 1/16-12UN
T	G 1/4	9/16-18UNF

Type	L <sub>max</sub> , in [mm]	L <sub>2</sub> , in [mm]	Type	L <sub>max</sub> , in [mm]	L <sub>2</sub> , in [mm]	L <sub>1</sub> , in [mm]
MLHTM 200	7.40 [188]	5.60 [142,3]	MLHTMC 200	8.48 [215,5]	6.69 [169,8]	.98 [25]
MLHTM 250	7.64 [194]	5.85 [148,6]	MLHTMC 250	8.74 [222,0]	6.93 [176,1]	1.23 [31,3]
MLHTM 315	7.99 [203]	6.21 [157,8]	MLHTMC 315	9.09 [231,0]	7.30 [185,3]	1.59 [40,5]
MLHTM 400	8.43 [214]	6.63 [168,3]	MLHTMC 400	9.51 [241,5]	7.71 [195,8]	2.01 [51]
MLHTM 470	8.74 [222]	6.94 [176,3]	MLHTMC 470	9.82 [249,5]	8.02 [203,8]	2.32 [59]
MLHTM 500	8.98 [228]	7.18 [182,3]	MLHTMC 500	10.06 [255,5]	8.26 [209,8]	2.56 [65]
MLHTM 630	8.82 [224]	7.02 [178,3]	MLHTMC 630	9.90 [251,5]	8.10 [205,8]	2.40 [61]
MLHTM 725	9.17 [233]	7.37 [187,3]	MLHTMC 725	10.26 [260,5]	8.46 [214,8]	2.76 [70]

### DIMENSIONS -MLHTMW

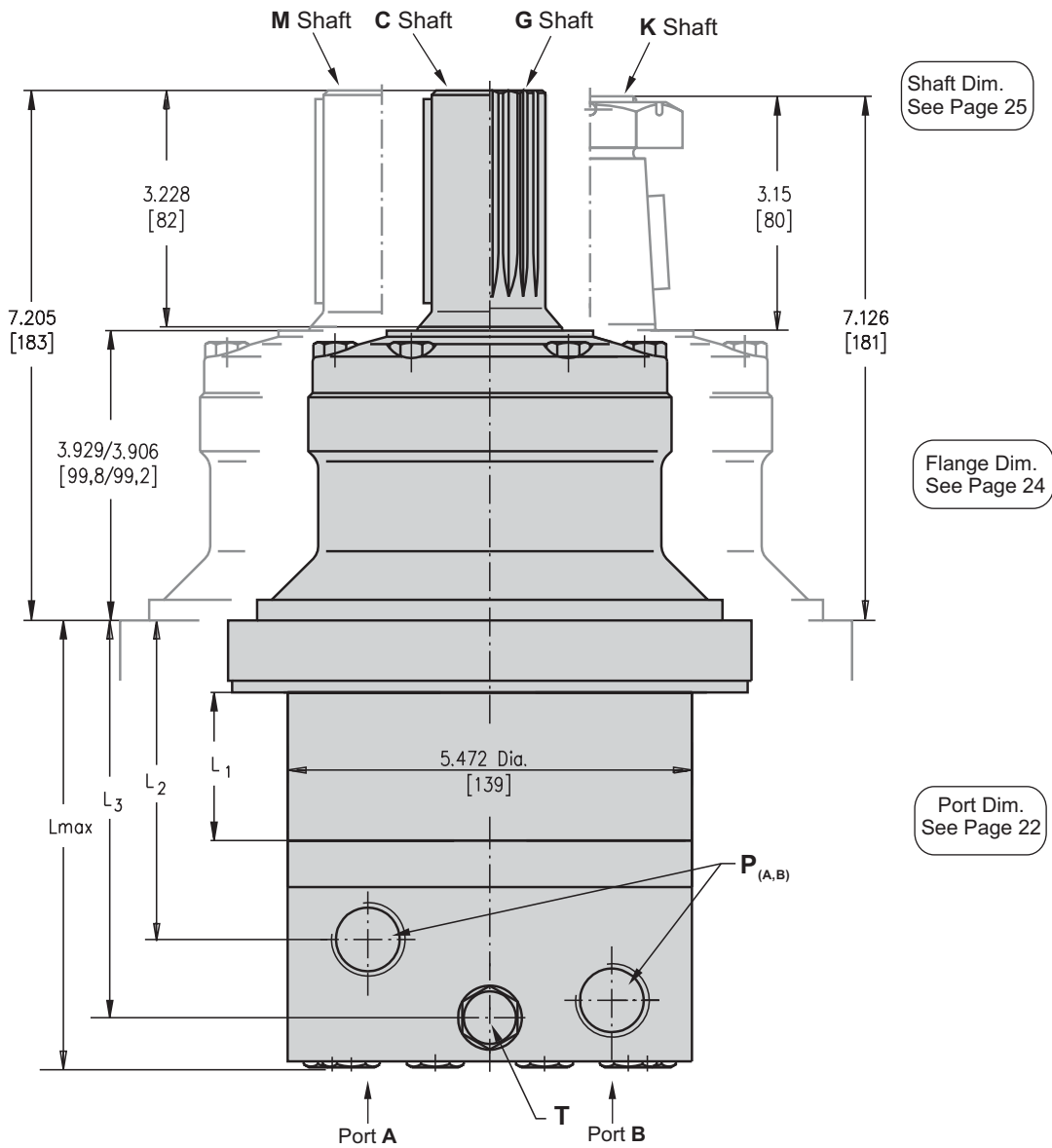

**Standard Rotation**

Viewed from Shaft End  
 Port A Pressurized - CW  
 Port B Pressurized - CCW

**Reverse Rotation**

Viewed from Shaft End  
 Port A Pressurized - CCW  
 Port B Pressurized - CW

Versions		
	2	4
<b>P (A,B)</b>	2XG 3/4	2X1 <sup>1</sup> / <sub>16</sub> -12UN
<b>T</b>	G 1/4	9 <sup>1</sup> / <sub>16</sub> -18UNF

Type	L <sub>max</sub> , in [mm]	L <sub>1</sub> , in [mm]	L <sub>2</sub> , in [mm]	L <sub>3</sub> , in [mm]
MLHTMW 200	5.08 [129]	.98 [25]	3.30 [83,8]	3.37 [111,1]
MLHTMW 250	5.32 [135]	1.23 [31,3]	3.55 [90,1]	4.62 [117,4]
MLHTMW 315	5.67 [144]	1.59 [40,5]	3.91 [99,3]	4.98 [126,6]
MLHTMW 400	6.10 [155]	2.01 [51]	4.32 [109,8]	5.40 [137,1]
MLHTMW 470	6.42 [163]	2.32 [59]	4.64 [117,8]	5.71 [145,1]
MLHTMW 500	6.65 [169]	2.56 [65]	4.87 [123,8]	5.95 [151,1]
MLHTMW 630	6.50 [165]	2.40 [61]	4.72 [119,8]	5.79 [147,1]
MLHTMW 725	6.85 [174]	2.76 [70]	5.07 [128,8]	6.15 [156,1]

**DIMENSIONS OF MOUNTING**

**4-Bolt flange**  
spigot diameter 6.3 in [160 mm] - BC 7.87 in [200 mm]

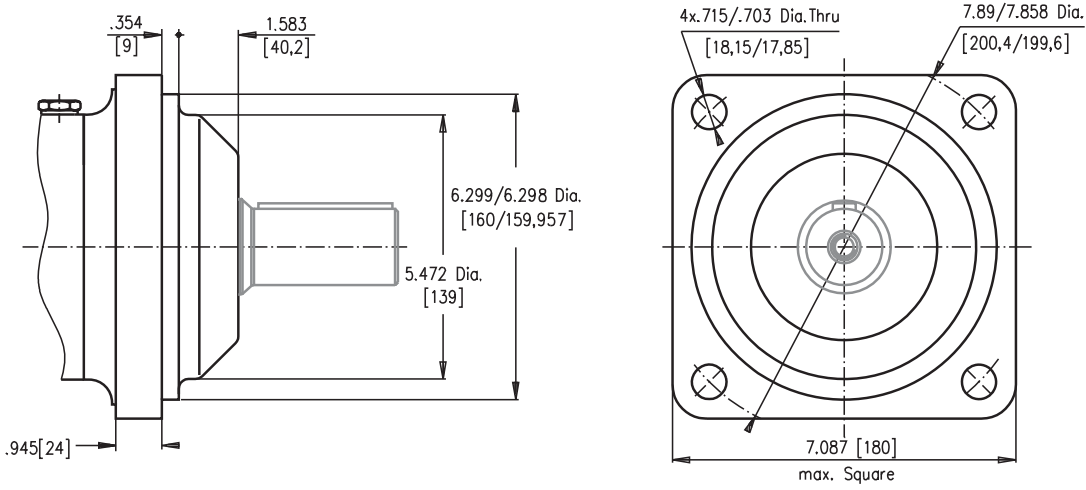

**C** 4-Bolt flange, SAE C mounting flange  
spigot diameter 5.00 in [127 mm]  
BC 6.37 in [161,9 mm]

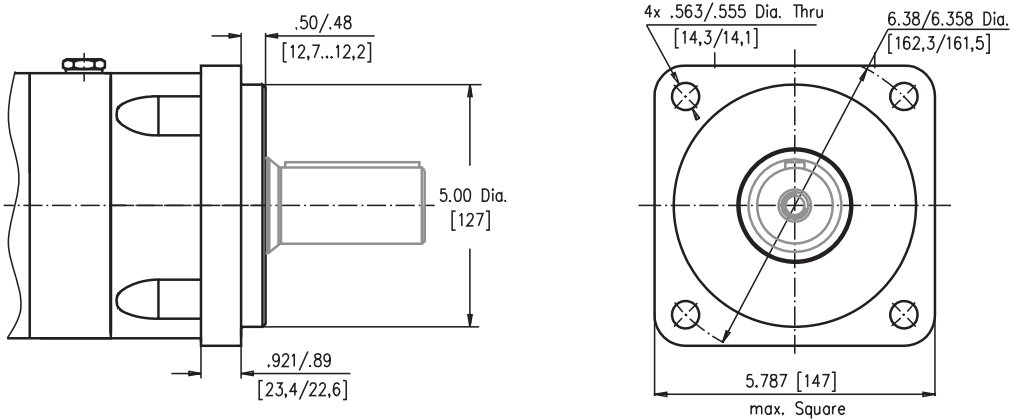

**W** 4-Bolt flange, Wheel Motor  
spigot diameter 6.3 in [160 mm] - BC 7.87 in [200 mm]

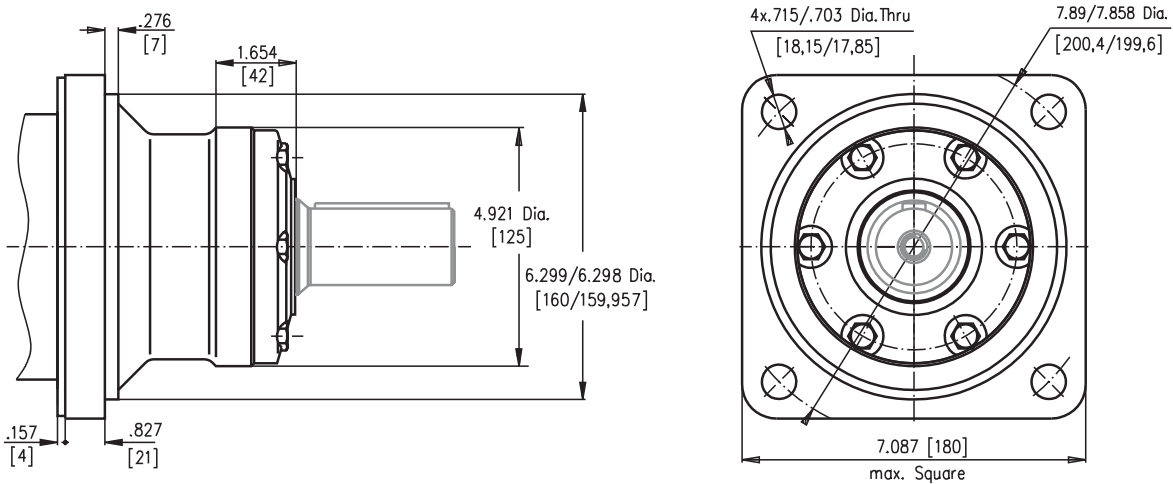



**SHAFT EXTENSIONS**

**C**

1 1/2" [38,1] srtaight, Parallel key 3/8"x 3/8"x 2 1/4" BS46  
Max. Torque 11750 lb-in [133 daNm]

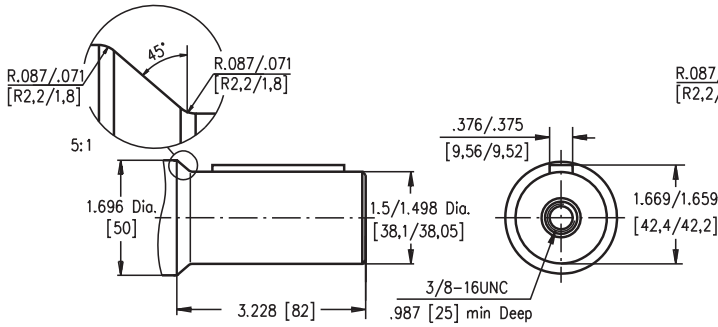

**M**

ø40 srtaight, Parallel key A12x8x70  
Max. Torque 11750 lb-in [133 daNm]

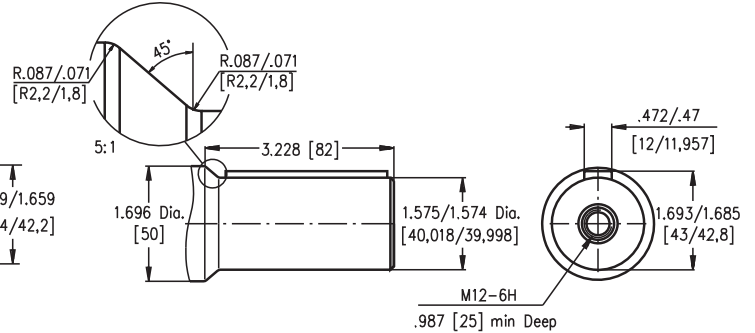

**G**

17T Splined, 1 1/2" [38,1] ANS B92.1-1976  
Max. Torque 11750 lb-in [133 daNm]

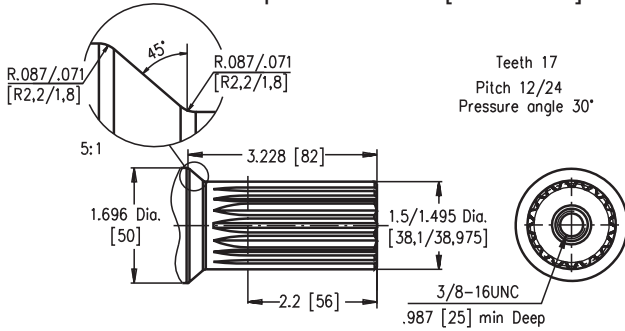

**T**

1 3/4" [44,5] SAE J501 Tapered 1:8  
Parallel key 7/16"x 7/16"x 1 1/4" BS46  
Max. Torque 18650 lb-in [210 daNm]

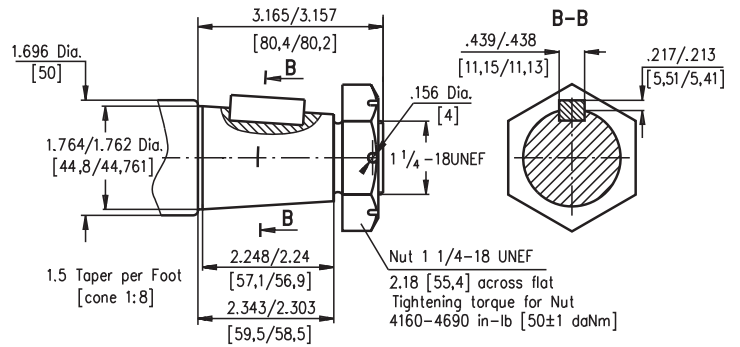

Requirement max. Torque must be not exceeded.

**PERMISSIBLE SHAFT LOADS**

The curves apply to a B10 bearing life (ISO281) of 2000 hours at 200 RPM.

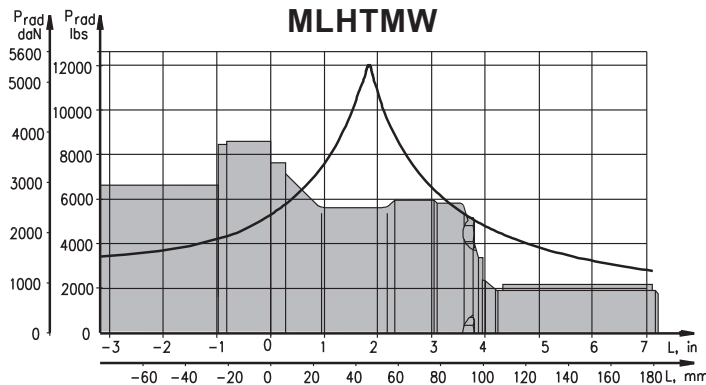
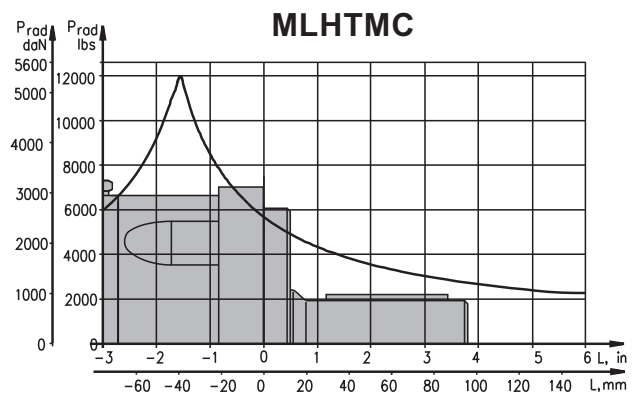
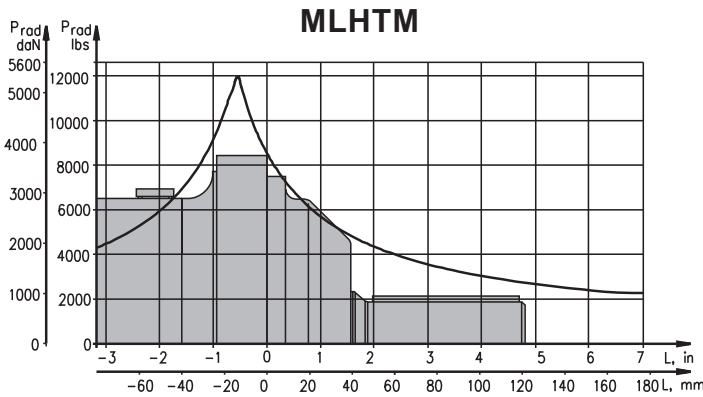

## OUTLINE DIMENSIONS REFERENCE FOR MLHTMV

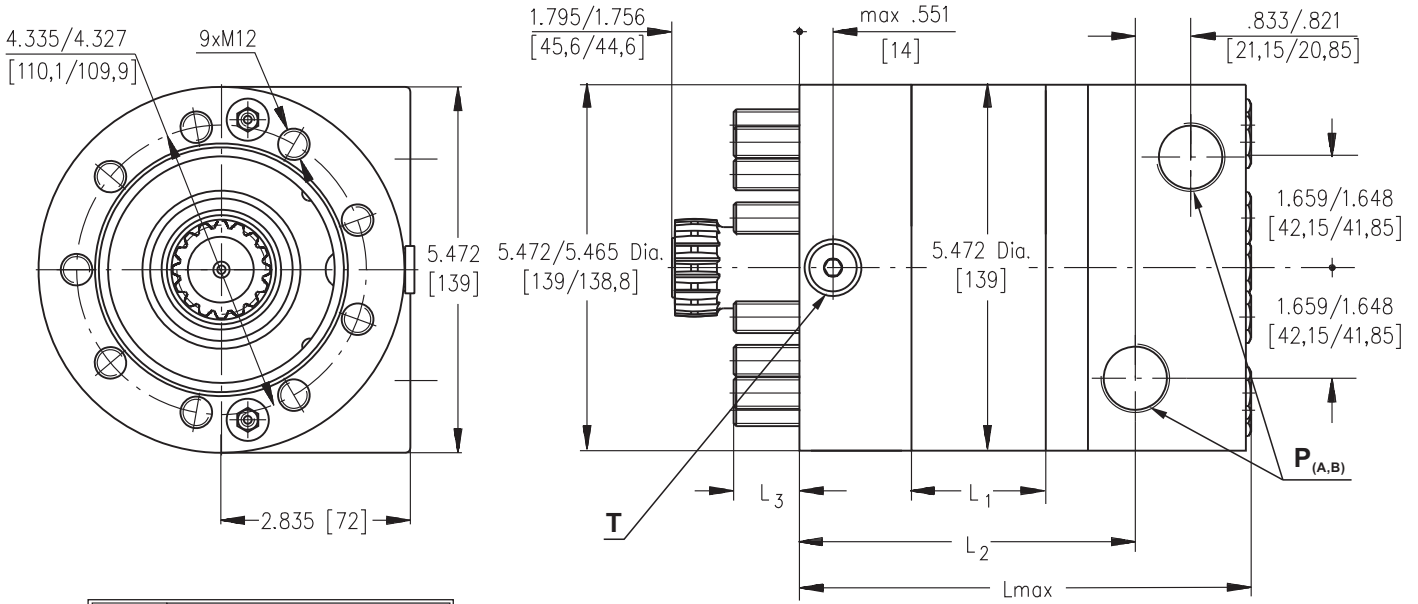

	Versions	
	2	4
<b>P</b> (A,B)	2xG 3/4	2x1 <sup>1</sup> / <sub>16</sub> -12UN
<b>T</b>	G 1/4	9/16-18UNF

**Standard Rotation**  
Viewed from Shaft End  
Port **A** Pressurized - **CW**  
Port **B** Pressurized - **CCW**

**Reverse Rotation**  
Viewed from Shaft End  
Port **A** Pressurized - **CCW**  
Port **B** Pressurized - **CW**

Type	L <sub>1</sub> , in [mm]	L, in [mm]	L <sub>2</sub> , in [mm]	L <sub>3</sub> , in [mm]
MLHTMV 200	.98 [25]	5.945 [151]	4.193 [106,5]	1.094 [27,8]
MLHTMV 250	1.23 [31,3]	6.181 [157]	4.441 [112,8]	1.043 [26,5]
MLHTMV 315	1.59 [40,5]	6.575 [167]	4.803 [122,0]	.878 [22,3]
MLHTMV 400	2.01 [51]	6.968 [177]	5.217 [132,5]	.858 [21,8]
MLHTMV 470	2.32 [59]	7.283 [185]	5.531 [140,5]	.937 [23,8]
MLHTMV 500	2.56 [65]	7.520 [191]	5.768 [146,5]	1.094 [27,8]
MLHTMV 630	2.40 [61]	7.362 [187]	5.610 [142,5]	1.055 [26,8]
MLHTMV 725	2.76 [70]	7.717 [196]	5.965 [151,5]	1.094 [27,8]

## DIMENSIONS OF THE ATTACHED COMPONENT

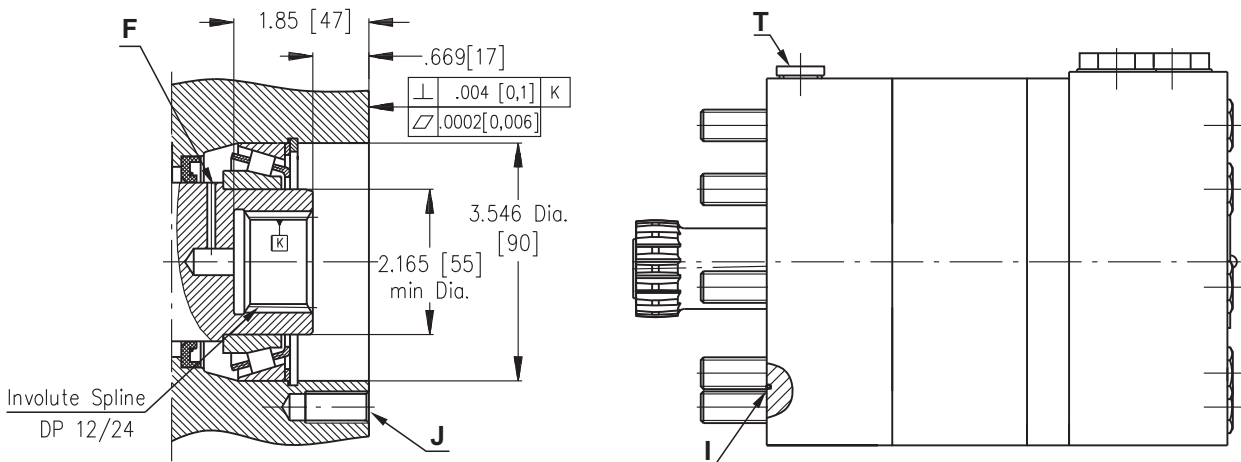

**F:** Oil circulation hole  
**J:** 9xM12-1.18 [30] depth, 40°, 4.331 [110] Dia. B. C.

**I:** O-Ring 3.661x.059 [93x1,5]  
**T:** Drain connection G1/4 or 9/16 - 18UNF



## OUTLINE DIMENSIONS REFERENCE FOR MLHTM6V

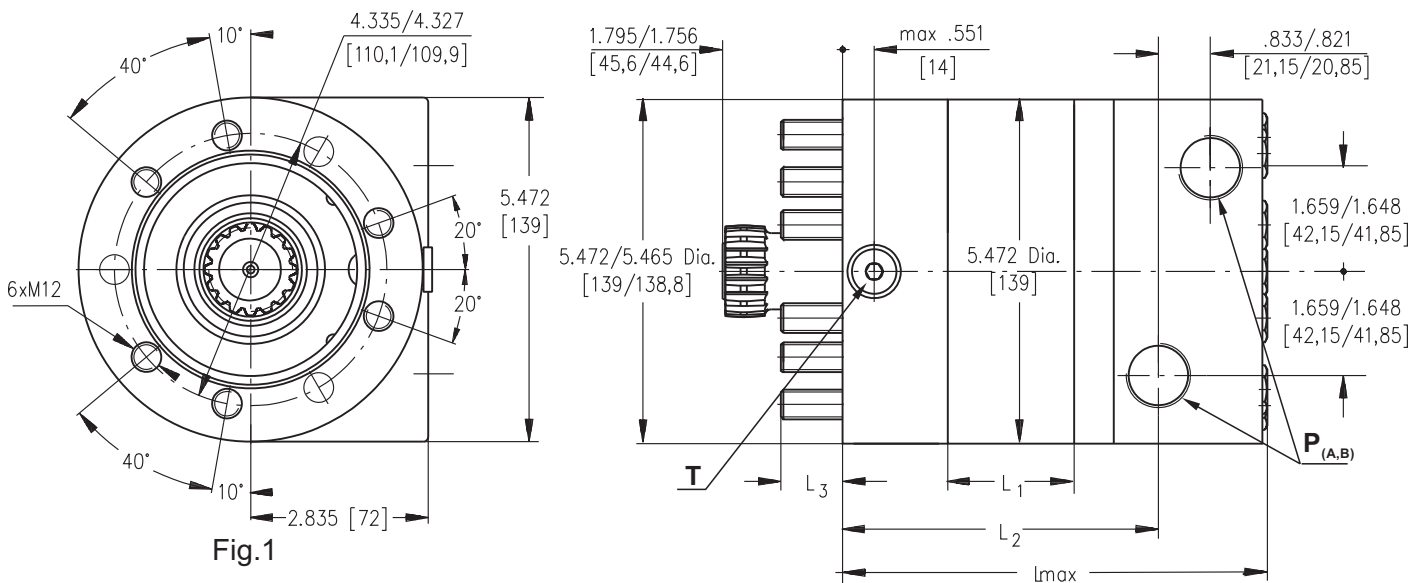

Fig.1

	Versions	
	2	4
<b>P (A,B)</b>	2XG 3/4	2X1½-12UN
<b>T</b>	G 1/4	9/16-18UNF

**Standard Rotation**

Viewed from Shaft End  
 Port **A** Pressurized - **CW**  
 Port **B** Pressurized - **CCW**

**Reverse Rotation**

Viewed from Shaft End  
 Port **A** Pressurized - **CCW**  
 Port **B** Pressurized - **CW**

Type	L <sub>1</sub> , in.[mm]	L, in.[mm]	L <sub>2</sub> , in.[mm]	L <sub>3</sub> , in.[mm]
MLHTM6V 200	.98 [25]	5.945 [151]	4.193 [106,5]	1.094 [27,8]
MLHTM6V 250	1.23 [31,3]	6.181 [157]	4.441 [112,8]	1.043 [26,5]
MLHTM6V 315	1.59 [40,5]	6.575 [167]	4.803 [122,0]	.878 [22,3]
MLHTM6V 400	2.01 [51]	6.968 [177]	5.217 [132,5]	.858 [21,8]
MLHTM6V 470	2.32 [59]	7.283 [185]	5.531 [140,5]	.937 [23,8]
MLHTM6V 500	2.56 [65]	7.520 [191]	5.768 [146,5]	1.094 [27,8]
MLHTM6V 630	2.40 [61]	7.362 [187]	5.610 [142,5]	1.055 [26,8]
MLHTM6V 725	2.76 [70]	7.717 [196]	5.965 [151,5]	1.094 [27,8]

### DIMENSIONS OF THE ATTACHED COMPONENT

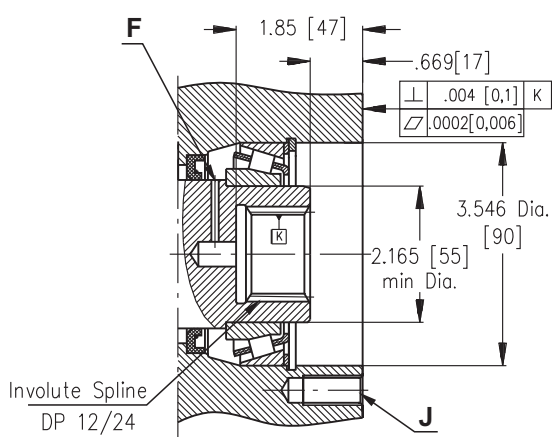

**F:** Oil circulation hole

**J:** 9xM12-1.18 [30] depth, 40°, 4.331[110] Dia. B. C. 6xM12-1.18 [30] , situated in accordance with the bolts M12, shown on Fig.1, 4.331[110] Dia. B. C.

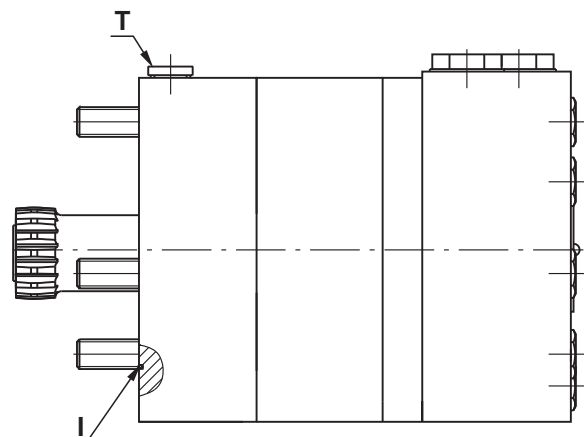

**I:** O- Ring 3.661x.059 [93x1,5]

**T:** Drain connection G1/4 or 9/16 - 18UNF



### DRAIN CONNECTION

A drain line ought to be used when pressure in the return line can exceed the permissible pressure. It can be connected at the drain connection of the attached component. The maximum pressure in the drain line is limited by the attached component and its shaft seal.

The drain line must be possible for oil to flow freely between motor and attached component and must be led to the tank. The maximum pressure in the drain line is limited by the attached component and its seal.

## INTERNAL SPLINE DATA FOR THE ATTACHED COMPONENT

Standard ANS B92.1-1976, class 5  
 [m=2.1166; corrected x.m=+1]

Fillet Root Side Fit		inch	mm
Number of Teeth	z	16	16
Diametral Pitch	DP	12/24	12/24
Pressure Angle		30 <sup>0</sup>	30 <sup>0</sup>
Pitch Dia.	D	1.3333	33,8656
Major Dia.	D <sub>ri</sub>	1.5118÷1.5275	38,4 <sup>+0,4</sup>
Minor Dia.	D <sub>i</sub>	1.2657÷1.2673	32,15 <sup>+0,04</sup>
Circular Space Width	Lo	.1763÷.1791	4,516±0,037
Fillet Radius	R	.02	0,5
Dimension Between Two Pins	L	1.063÷1.059	26,9 <sup>+0,10</sup>
Pin Dia.	d	.19026÷.19034	4,835±0,001

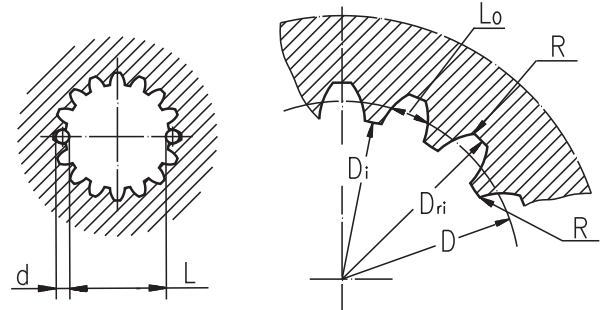

**Hardening Specification:**  
 HV=750±50 on the surface.  
 HV=560 at .035±.019 [0,7±0,2] case depth  
 Material: 20 MoCr4 EN 10084 or SAE8620.

## ORDER CODE

1	2	3	4	5	6
<b>M</b>	<b>L</b>	<b>H</b>	<b>T</b>	<b>M</b>	<b>M</b>

### Pos.1 - Mounting Flange

- omit - 4-Bolt flange, spigot dia. 6.3 in, BC 7.87 in
- C** - SAE C, 4-Bolt flange, spigot dia. 5 in, BC 6.37 in
- W** - Wheel motor, spigot dia. 6.3 in, BC 7.87 in
- V** - Veryshort mount, 9xM12 mounting bolts
- 6V** - Veryshort mount, 6xM12 mounting bolts

### Pos.2 - Displacement code

- 200** - 12.29 in<sup>3</sup>/rev [201,4 cm<sup>3</sup>/rev]
- 250** - 15.36 in<sup>3</sup>/rev [251,8 cm<sup>3</sup>/rev]
- 315** - 19.90 in<sup>3</sup>/rev [326,3 cm<sup>3</sup>/rev]
- 400** - 25.06 in<sup>3</sup>/rev [410,9 cm<sup>3</sup>/rev]
- 470** - 28.97 in<sup>3</sup>/rev [475,0 cm<sup>3</sup>/rev]
- 500** - 31.95 in<sup>3</sup>/rev [523,6 cm<sup>3</sup>/rev]
- 630** - 38.52 in<sup>3</sup>/rev [631,2 cm<sup>3</sup>/rev]
- 725** - 44.20 in<sup>3</sup>/rev [724,3 cm<sup>3</sup>/rev]

### Pos.3 - Shaft Extensions\*

- C** - 1½" [38,10] straight, Parallel key
- G** - 1½" [38,10] 17T Splined
- M** - ø40 mm straight, Parallel key
- T** - 1¾" [44,50] J501 Tapered

### Pos.4 - Port Size/Type [standard manifold to each]

- 2** - side ports, 2xG 3/4, G1/4, BSP thread, ISO 228
- 4** - side ports, 2xG1 1/16-12 UN, O-ring, 9/16-18 UNF

### Pos.5 - Check Valves

- omit - without check valves
- 1** - with check valves

### Pos.6 - Special Features [see page 48]

### Pos.7 - Design Series

- omit - Factory specified

Notes: \* The permissible output torque for shafts must be not exceeded!

The hydraulic motors are mangano phosphatized as standard.

# HYDRAULIC MOTORS TMF



## APPLICATION

- » Marine equipment
- » Forestry equipment
- » Metal working machines
- » Agriculture machines
- » Road building machines
- » Mining machinery
- » Special vehicles etc.

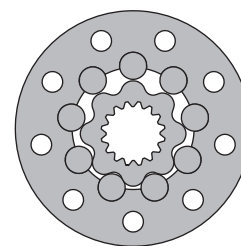

## CONTENTS

Specification data .....	30
Dimensions and mounting TMF.....	31
Dimensions and mounting TMFA .....	32
Permissible shaft loads .....	33
Order code .....	33

## OPTIONS

- » Model- Disc valve, roll-gerotor
- » Wheel mounting flange
- » Side ports
- » Shaft- thread hole flange
- » SAE and BSPP ports
- » Other special features

## GENERAL

<b>Max. Displacement,</b> in <sup>3</sup> /rev [cm <sup>3</sup> /rev]	44.2 [724,3]
<b>Max. Speed,</b> [RPM]	750
<b>Max. Torque,</b> lb-in [daNm]	cont.: 16200 [183] int.: 20270 [229]
<b>Max. Output,</b> HP [kW]	94 [70]
<b>Max. Pressure Drop,</b> PSI [bar]	cont.: 3600 [250] int.: 5080 [350]
<b>Max. Oil Flow,</b> GPM [lpm]	40 [150]
<b>Min. Speed,</b> [RPM]	5
<b>Permissible Shaft Loads</b> lbs [daN]	P <sub>a</sub> =2250 [1000]
<b>Pressure fluid</b>	Mineral based- HLP(DIN 51524) or HM(ISO 6743/4)
<b>Temperature range,</b> °F [°C]	-40÷284 [-40÷140]
<b>Optimal Viscosity range, SUS [mm<sup>2</sup>/s]</b>	98÷347 [20÷75]
<b>Filtration</b>	ISO code 20/16 (Min. recommended fluid filtration of 25 micron)

### Oil flow in drain line

Pressure drop PSI [bar]	Viscosity SUS [mm <sup>2</sup> /s]	Oil flow in drain line GPM [lpm]
2900 [200]	98 [20]	.660 [2,5]
	164 [35]	.400 [1,5]
3990 [275]	98 [20]	1.057 [4]
	164 [35]	.660 [2,5]

### Pressure Losses

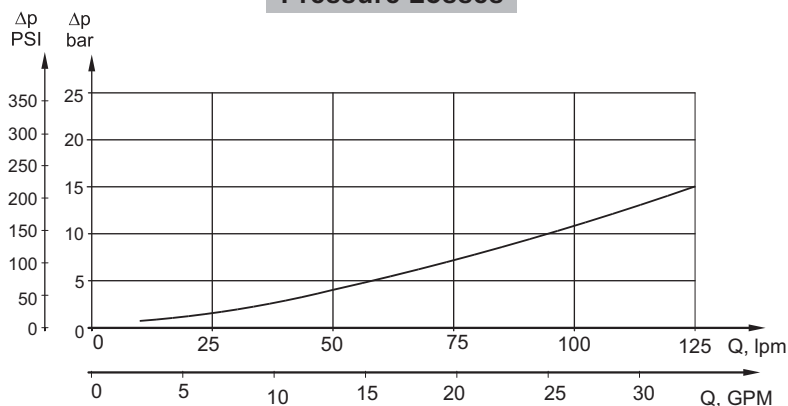

## SPECIFICATION DATA

Type	TMF 200	TMF 250	TMF 315	TMF 400	TMF 470	TMF 500	TMF 630	TMF 725	
<b>Displacement, in<sup>3</sup>/rev [cm<sup>3</sup>/rev]</b>	12.29 [201,4]	15.36 [251,8]	19.9 [326,3]	25.06 [410,9]	28.97 [475]	31.95 [523,6]	38.52 [631,2]	44.2 [724]	
<b>Max. Speed, [RPM]</b>	Cont.	625	500	380	305	260	240	190	
	Int.*	750	600	460	365	315	285	230	
<b>Max. Torque lb-in [daNm]</b>	Cont.	6375 [72]	7965[90]	10265[116]	13010[147]	15135[171]	15225[172]	16200[183]	14160[160]
	Int.*	9030[102]	11330[128]	14425[163]	18232[206]	16030[215]	19030[215]	20270[229]	17000[192]
	Peak**	10180[115]	12745[144]	16460[186]	20800[235]	21240[240]	21240[240]	24250[274]	21240[240]
<b>Max. Output HP [kW]</b>	Cont.	55 [41]	55 [41]	55 [41]	55 [41]	55 [41]	50[37,5]	37,5 [28]	35 [26]
	Int.*	87 [65]	94[70]	94[70]	94[70]	74[55]	68 [51]	56 [42]	54 [40]
<b>Max. Pressure Drop PSI [bar]</b>	Cont.	3600[250]	3600[250]	3600[250]	3600[250]	3600[250]	3340[230]	2900[200]	2320[160]
	Int.*	5080[350]	5080[350]	5080[350]	5080[350]	4570[315]	4060[280]	3625[250]	3045[210]
	Peak**	5800[400]	5800[400]	5800[400]	5800[400]	5080[350]	4640[320]	4350[300]	3770[260]
<b>Max. Oil Flow GPM [lpm]</b>	Cont.	33[125]	33[125]	33[125]	33[125]	33[125]	33[125]	33[125]	33[125]
	Int.*	40[150]	40[150]	40[150]	40[150]	40[150]	40[150]	40[150]	40[150]
<b>Max. Inlet Pressure PSI [bar]</b>	Cont.	3920[270]	3920[270]	3920[270]	3920[270]	3920[270]	3920[270]	3920[270]	3920[270]
	Int.*	5370[370]	5370[370]	5370[370]	5370[370]	5370[370]	5370[370]	5370[370]	5370[370]
	Peak**	6100[420]	6100[420]	6100[420]	6100[420]	6100[420]	6100[420]	6100[420]	6100[420]
<b>Max. Return Pressure without Drain Line or Max. Pressure in Drain Line, PSI [bar]</b>	Cont. 0-100 RPM	1100 [75]	1100 [75]	1100 [75]	1100 [75]	1100 [75]	1100 [75]	1100 [75]	1100 [75]
	Cont. 100-300 RPM	580 [40]	580 [40]	580 [40]	580 [40]	580 [40]	580 [40]	580 [40]	580 [40]
	Cont. >300 RPM	290 [20]	290 [20]	290 [20]	290 [20]	290 [20]	-	-	-
	Int.* 0-max. RPM	1100 [75]	1100 [75]	1100 [75]	1100 [75]	1100 [75]	1100 [75]	1100 [75]	1100 [75]
<b>Max. Return Pressure with Drain Line PSI [bar]</b>	Cont.	3920[270]	3920[270]	3920[270]	3920[270]	3920[270]	3920[270]	3920[270]	3920[270]
	Int.*	5370[370]	5370[370]	5370[370]	5370[370]	5370[370]	5370[370]	5370[370]	5370[370]
	Peak**	6100[420]	6100[420]	6100[420]	6100[420]	6100[420]	6100[420]	6100[420]	6100[420]
<b>Max. Starting Pressure with Unloaded Shaft, PSI [bar]</b>	90 [6]	90 [6]	90 [6]	90 [6]	90 [6]	90 [6]	90 [6]	90 [6]	
<b>Min. Starting Torque lb-in [daNm]</b>	5310[60]	6640[75]	8585[97]	10800[122]	12570[142]	12655[143]	12830[145]	13100[148]	
<b>Min. Speed***, [RPM]</b>	5	5	5	5	5	5	5	5	
<b>Weight, lb [kg]</b>	59.3 [26,9]	60.2 [27,3]	62 [28,1]	64 [29]	65.5 [29,7]	66.6 [30,2]	65.5 [29,7]	68.4 [31]	

\* Intermittent operation: the permissible values may occur for max. 10% of every minute.

\*\* Peak load: the permissible values may occur for max. 1% of every minute.

\*\*\* For speeds lower than given, consult factory or your regional manager.

- Intermittent speed and intermittent pressure drop must not occur simultaneously.
- Recommended filtration is per ISO cleanliness code 20/16. A nominal filtration of 25 micron or better.
- Recommend using a premium quality, anti-wear type mineral based hydraulic oil HLP(DIN51524) or HM (ISO 6743/4).  
If using synthetic fluids consult the factory for alternative seal materials.
- Recommended minimum oil viscosity 70 SUS [13 mm<sup>2</sup>/s] at 122°F [50°C].
- Recommended maximum system operating temperature is 180°F [82°C].
- To assure optimum motor life fill with fluid prior to loading and run at moderate load and speed for 10-15 minutes.

### DIMENSIONS AND MOUNTING DATA - TMF

**P<sub>(A,B)</sub>**: 2xG3/4 - .669 in [17 mm] depth  
**T** : G1/4 - .472 in [12 mm] depth

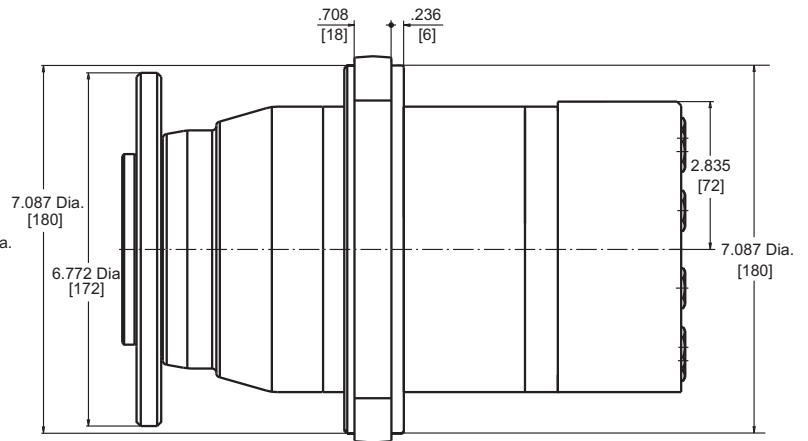
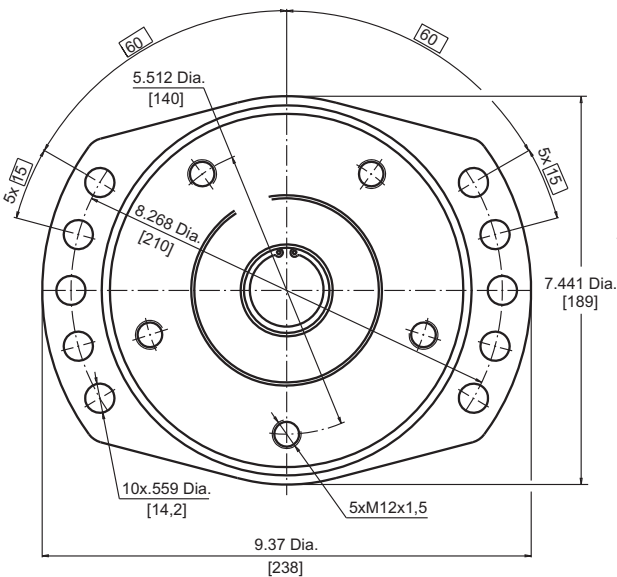
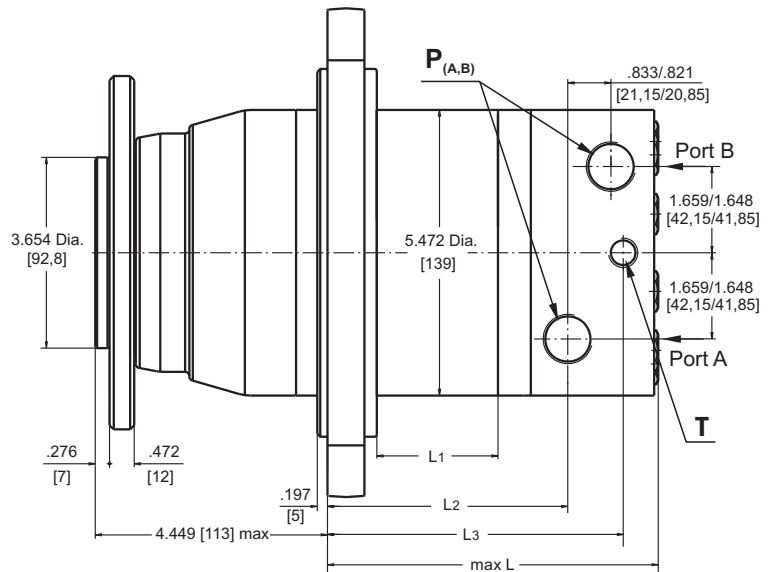

**Warning:** Drain line should always be used.



**Standard Rotation**  
 Viewed from Shaft End  
 Port **A** Pressurized - **CW**  
 Port **B** Pressurized - **CCW**

**Reverse Rotation**  
 Viewed from Shaft End  
 Port **A** Pressurized - **CCW**  
 Port **B** Pressurized - **CW**

Type	L <sub>max</sub> , in [mm]	L <sub>1</sub> , in [mm]	L <sub>2</sub> , in [mm]	L <sub>3</sub> , in [mm]
TMF 200	4.96 [126]	25 [.98]	3.268 [83]	4.34 [110,3]
TMF 250	5.21 [132,3]	1.23 [31,3]	3.516 [89,3]	4.59 [116,6]
TMF 315	5.57 [141,5]	1.59 [40,5]	3.878 [98,5]	4.95 [125,8]
TMF 400	5.98 [152]	2.01 [51]	4.291 [109]	5.37 [136,3]
TMF 470	6.30 [160]	2.32 [59]	4.606 [117]	5.68 [144,3]
TMF 500	6.54 [166]	2.56 [65]	4.843 [123]	5.92 [150,3]
TMF 630	6.38 [162]	2.40 [61]	4.69 [119]	5.76 [146,3]
TMF 725	6.73 [171]	2.76 [70]	5.04 [128]	6.11 [155,3]

## DIMENSIONS AND MOUNTING DATA - TMFA

**P<sub>(A,B)</sub>**: 2x1 1/16-12 UN, O-ring port  
 .669 in [17 mm] depth  
**T** : 9/16-18 UNF, O-ring port  
 .472 in [12 mm] depth

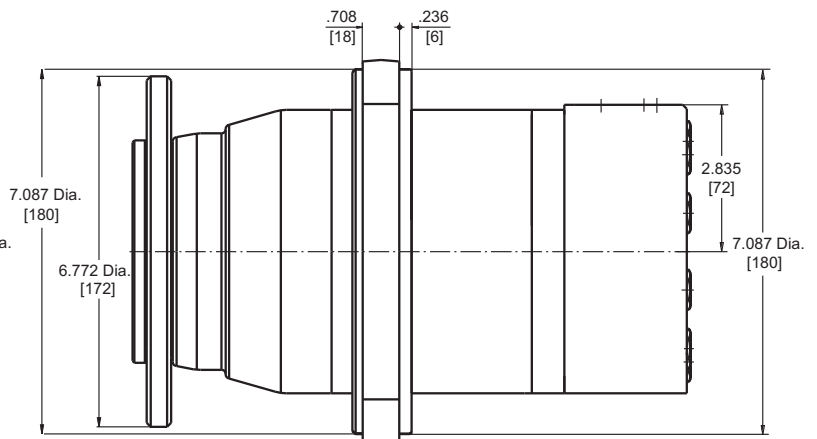
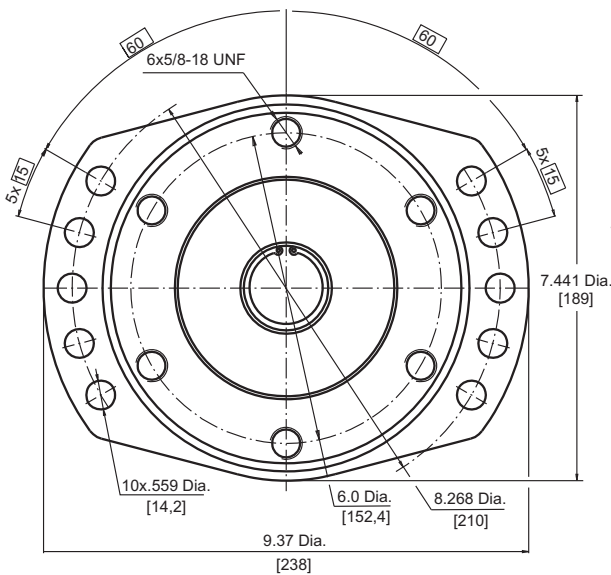
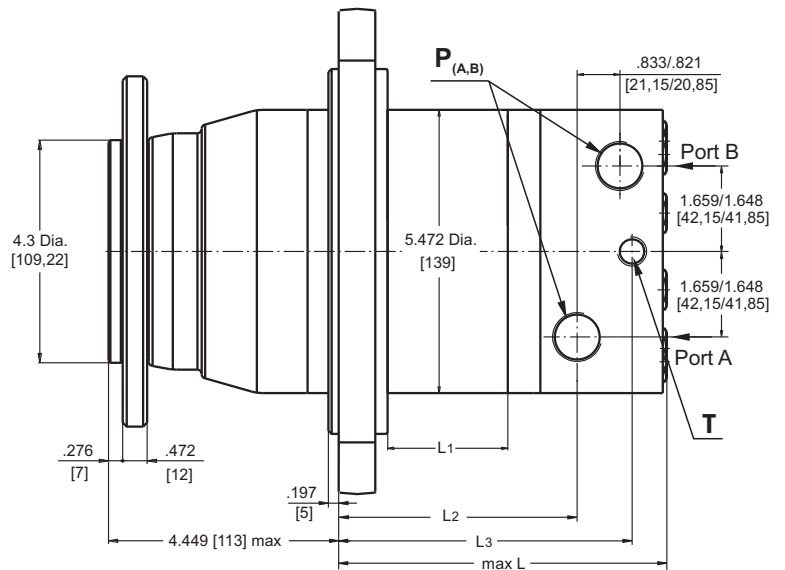

**Warning:** Drain line should always be used.



**Standard Rotation**  
 Viewed from Shaft End  
 Port **A** Pressurized - **CW**  
 Port **B** Pressurized - **CCW**  
**Reverse Rotation**  
 Viewed from Shaft End  
 Port **A** Pressurized - **CCW**  
 Port **B** Pressurized - **CW**

Type	L <sub>max</sub> , in [mm]	L <sub>1</sub> , in [mm]	L <sub>2</sub> , in [mm]	L <sub>3</sub> , in [mm]
TMFA 200	4.96 [126]	25 [.98]	3.268 [83]	4.34 [110,3]
TMFA 250	5.21 [132,3]	1.23 [31,3]	3.516 [89,3]	4.59 [116,6]
TMFA 315	5.57 [141,5]	1.59 [40,5]	3.878 [98,5]	4.95 [125,8]
TMFA 400	5.98 [152]	2.01 [51]	4.291 [109]	5.37 [136,3]
TMFA 470	6.30 [160]	2.32 [59]	4.606 [117]	5.68 [144,3]
TMFA 500	6.54 [166]	2.56 [65]	4.843 [123]	5.92 [150,3]
TMFA 630	6.38 [162]	2.40 [61]	4.69 [119]	5.76 [146,3]
TMFA 725	6.73 [171]	2.76 [70]	5.04 [128]	6.11 [155,3]



## PERMISSIBLE SHAFT LOADS

The load diagram is valid for an average bearings life of 2000 hours at 100 RPM

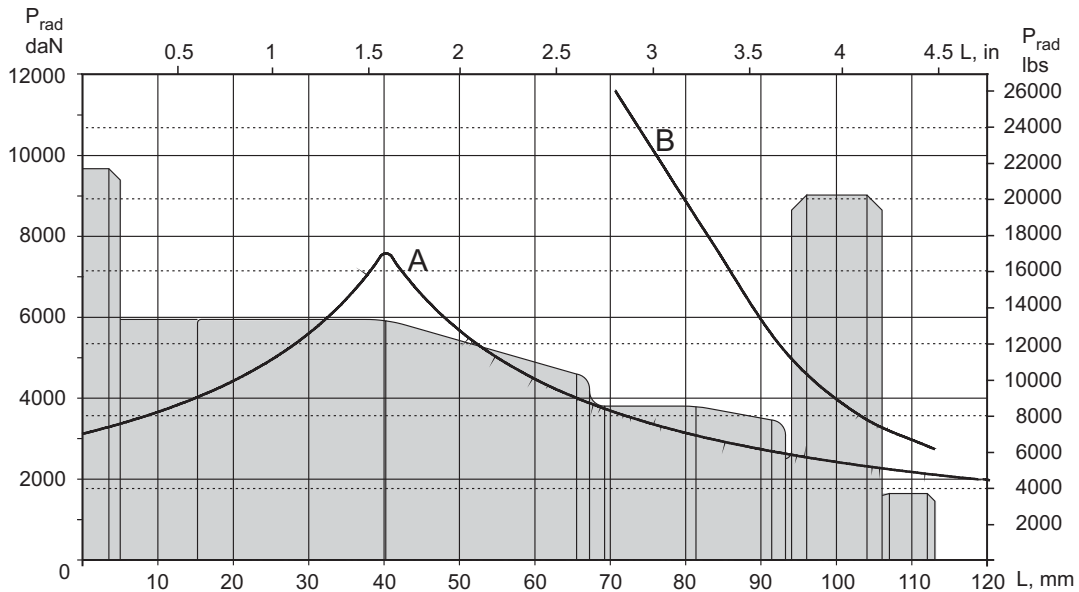

- A** - Permissible radial shaft load.
- B** - Max. radial shaft load. Any shaft load exceeding the values shown in the curve will involve a risk of breakage

### ORDER CODE

	1	2	3	4
<b>TMF</b>				

**Pos.1 - Mounting Flange**

omit - Thread hole flange, 5xM12x1,5 on  $\varnothing$ 140

**A** - Thread hole flange, 6x5/8-18 UNF on  $\varnothing$ 152,4

**Pos.2 - Displacement code**

**200** - 12.29 in<sup>3</sup>/rev [201,4 cm<sup>3</sup>/rev]

**250** - 15.36 in<sup>3</sup>/rev [251,8 cm<sup>3</sup>/rev]

**315** - 19.90 in<sup>3</sup>/rev [326,3 cm<sup>3</sup>/rev]

**400** - 25.06 in<sup>3</sup>/rev [410,9 cm<sup>3</sup>/rev]

**470** - 28.97 in<sup>3</sup>/rev [475,0 cm<sup>3</sup>/rev]

**500** - 31.95 in<sup>3</sup>/rev [523,6 cm<sup>3</sup>/rev]

**630** - 38.52 in<sup>3</sup>/rev [631,2 cm<sup>3</sup>/rev]

**725** - 44.20 in<sup>3</sup>/rev [724,3 cm<sup>3</sup>/rev]

**Pos.3 - Special Features** [see page 48]

**Pos.4 - Design Series**

omit - Factory specified

The hydraulic motors are manganophosphatized as standard.

# HYDRAULIC MOTORS MVM



## APPLICATION

- » Conveyors
- » Metal working machines
- » Agriculture machines
- » Road building machines
- » Mining machinery
- » Food industries
- » Special vehicles
- » Plastic and rubber machinery etc.

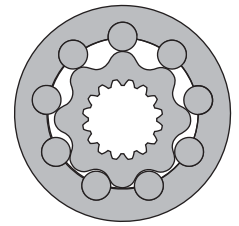
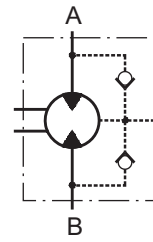
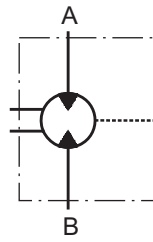

## CONTENTS

Specification data .....	35
Dimensions and mounting .....	36
Shaft extensions .....	37
Permissible shaft Seal Pressure ....	37
Permissible shaft loads .....	38
Order code .....	38

## OPTIONS

- » Model- Disc valve, roll-gerotor
- » Flange with wheel mount
- » Short motor
- » Side ports
- » Shafts- straight, splined and tapered
- » BSPP ports;
- » Other special features.

## EXCELLENCE

- » High torque and pressure drop
- » High inlet pressure
- » High starting torque
- » Improved efficiency at high pressure drop
- » Smooth operation at low speed
- » High radial and axial bearing capacity

## GENERAL

<b>Max. Displacement,</b> in <sup>3</sup> /rev [cm <sup>3</sup> /rev]	48.91 [801,8]
<b>Max. Speed,</b> [RPM]	763
<b>Max. Torque,</b> lb-in [daNm]	cont.: 22920 [259] int.: 30090 [340]
<b>Max. Output,</b> HP [kW]	150 [112]
<b>Max. Pressure Drop,</b> PSI [bar]	cont.: 3630 [250] int.: 5080 [350]
<b>Max. Oil Flow,</b> GPM [lpm]	63.4 [240]
<b>Min. Speed,</b> [RPM]	5
<b>Permissible Shaft Loads,</b> lbs [daN]	Pa=3370 [1500]
<b>Pressure fluid</b>	Mineral based- HLP(DIN 51524) or HM(ISO 6743/4)
<b>Temperature range,</b> °F [°C]	-40÷284 [-40÷140]
<b>Optimal Viscosity range, SUS [mm<sup>2</sup>/s]</b>	98÷347 [20÷75]
<b>Filtration</b>	ISO code 20/16 (Min. recommended fluid filtration of 25 micron)

### Oil flow in drain line

Pressure drop PSI [bar]	Viscosity SUS [mm <sup>2</sup> /s]	Oil flow in drain line lpm [GPM]
2900 [200]	98 [20]	.660 [2,5]
	164 [35]	.400 [1,5]
3990 [275]	98 [20]	1.057 [4]
	164 [35]	.660 [2,5]

### Pressure Losses

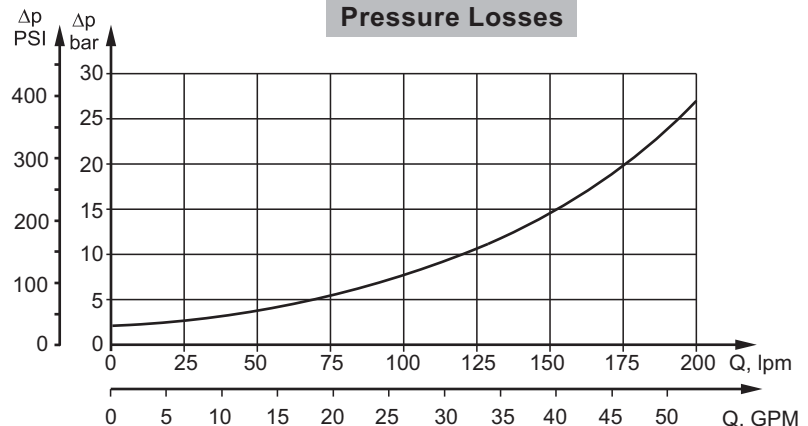

## SPECIFICATION DATA

Type	MVM 315	MVM 400	MVM 500	MVM 630	MVM 800	
<b>Displacement, in<sup>3</sup>/rev [cm<sup>3</sup>/rev]</b>	19.18 [314,5]	24.5 [400,9]	30.5 [499,6]	38.38 [629,1]	48.91 [801,8]	
<b>Max. Speed, [RPM]</b>	cont.	636	500	400	315	250
	Int.*	763	600	480	380	300
<b>Max. Torque lb-in [daNm]</b>	cont.	10180 [115]	12745 [144]	15930 [180]	20090 [227]	22920 [259]
	Int.*	14160 [160]	17700 [200]	23010 [260]	27440 [310]	30090 [340]
	peak**	15930 [180]	20355 [230]	25315 [286]	31860 [360]	35580 [402]
<b>Max. Output HP [kW]</b>	cont.	90 [67]	90 [67]	90 [67]	90 [67]	90 [67]
	int.*	150 [112]	150 [112]	150 [112]	150 [112]	150 [112]
<b>Max. Pressure Drop PSI [bar]</b>	cont.	3630 [250]	3630 [250]	3630 [250]	3630 [250]	3263 [225]
	Int.*	5080 [350]	5080 [350]	5080 [350]	5080 [350]	4350 [300]
	peak**	5800 [400]	5800 [400]	5800 [400]	5800 [400]	5080 [350]
<b>Max. Oil Flow GPM [lpm]</b>	cont.	52.8 [200]	52.8 [200]	52.8 [200]	52.8 [200]	52.8 [200]
	Int.*	63.4 [240]	63.4 [240]	63.4 [240]	63.4 [240]	63.4 [240]
<b>Max. Inlet Pressure PSI [bar]</b>	cont.	3915 [270]	3915 [270]	3915 [270]	3915 [270]	3915 [270]
	Int.*	5365 [370]	5365 [370]	5365 [370]	5365 [370]	5365 [370]
	peak**	6090 [420]	6090 [420]	6090 [420]	6090 [420]	6090 [420]
<b>Max. Return Pressure with Drain Line PSI [bar]</b>	cont.	2030 [140]	2030 [140]	2030 [140]	2030 [140]	2030 [140]
	Int.*	2540 [175]	2540 [175]	2540 [175]	2540 [175]	2540 [175]
	peak**	3045 [210]	3045 [210]	3045 [210]	3045 [210]	3045 [210]
<b>Max. Starting Pressure with Unloaded Shaft, PSI [bar]</b>	70 [5]	70 [5]	70 [5]	70 [5]	70 [5]	
<b>Min. Starting Torque lb-in [daNm]</b>	8140 [92]	10180 [115]	12745 [144]	15930 [180]	18145 [205]	
<b>Min. Speed***, [RPM]</b>	10	6	8	6	5	
<b>Weight, lb [kg]</b>	91 [41,3]	93 [42,1]	95 [43]	98 [44,5]	101.4 [46]	

\* Intermittent operation: the permissible values may occur for max. 10% of every minute.

\*\* Peak load: the permissible values may occur for max. 1% of every minute.

\*\*\* For speeds lower than given, consult factory or your regional manager.

1. Intermittent speed and intermittent pressure drop must not occur simultaneously.
2. Recommended filtration is per ISO cleanliness code 20/16. A nominal filtration of 25 micron or better.
3. Recommend using a premium quality, anti-wear type mineral based hydraulic oil HLP(DIN51524) or HM (ISO 6743/4).  
If using synthetic fluids consult the factory for alternative seal materials.
4. Recommended minimum oil viscosity 70 SUS [13 mm<sup>2</sup>/s] at 122°F [50°C].
5. Recommended maximum system operating temperature is 180°F [82°C].
6. To assure optimum motor life fill with fluid prior to loading and run at moderate load and speed for 10-15 minutes.

**DIMENSIONS AND MOUNTING DATA**

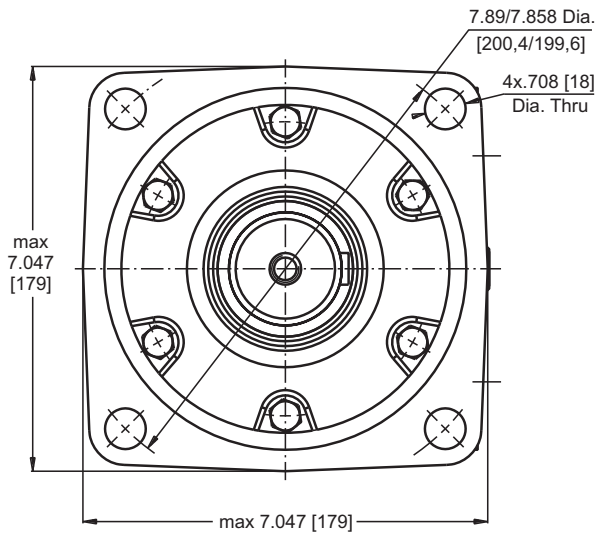

	Versions	
	2	4
P(A,B)	2xG1	2x1 <sup>5</sup> / <sub>16</sub> -12UN
T	G <sup>1</sup> / <sub>4</sub>	<sup>9</sup> / <sub>16</sub> -18UNF

Type	L, in [mm]	L <sub>2</sub> , in [mm]	L <sub>1</sub> , in [mm]
MVM 315	8.92 [226,5]	6.79 [172,5]	1.00 [25,5]
MVM 400	9.19 [233,5]	7.07 [179,5]	1.28 [32,5]
MVM 500	9.51 [241,5]	7.38 [187,5]	1.59 [40,5]
MVM 630	9.92 [252,0]	7.79 [198,0]	2.01 [51,0]
MVM 800	10.47 [266,0]	8.35 [212,0]	2.56 [65,0]

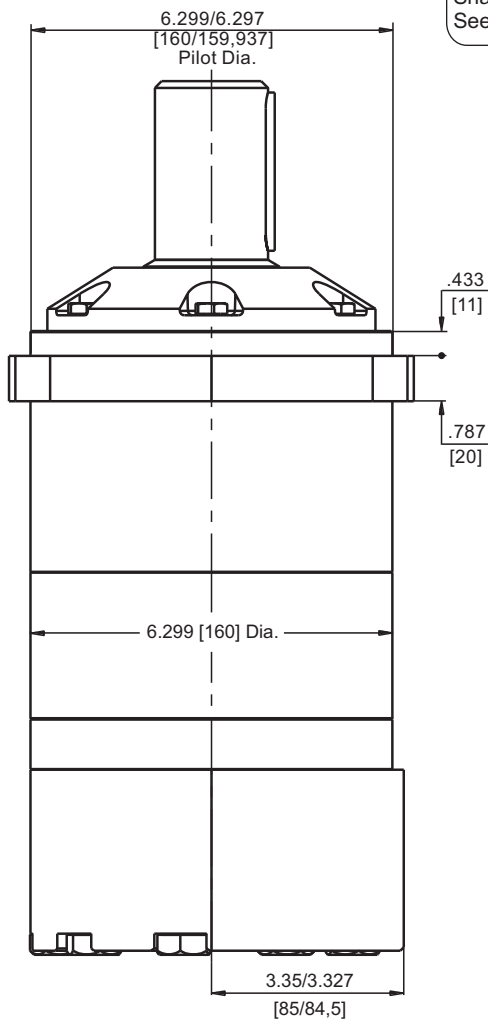

Shaft Dim.  
See Page 37

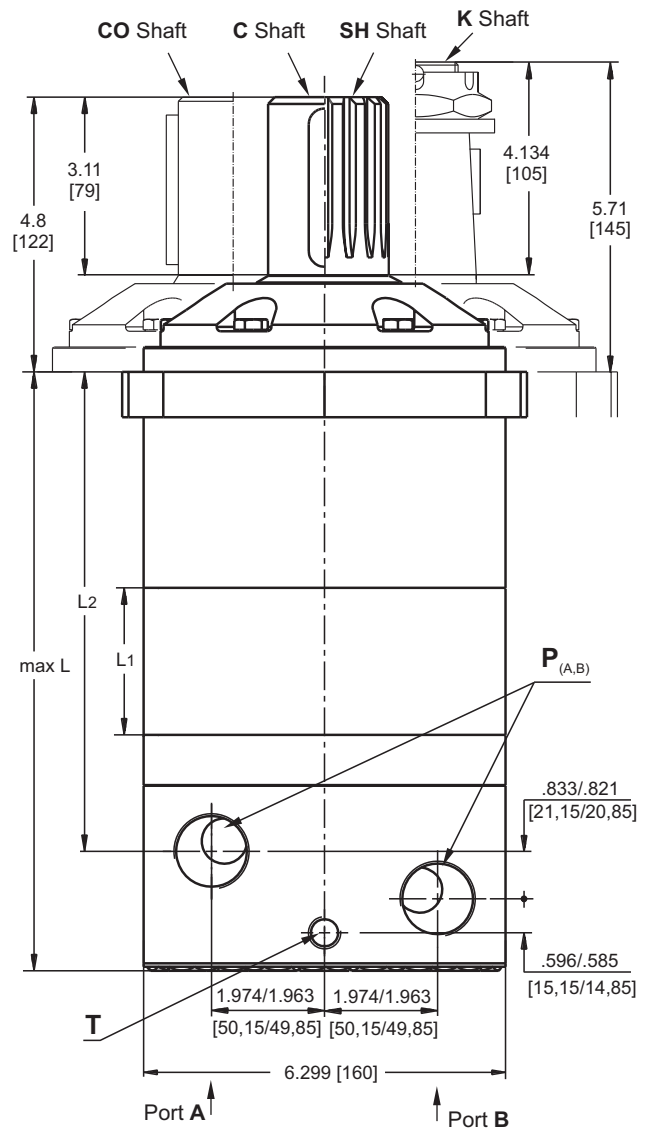

**Standard Rotation**  
Viewed from Shaft End  
Port A Pressurized - CW  
Port B Pressurized - CCW

**Reverse Rotation**  
Viewed from Shaft End  
Port A Pressurized - CCW  
Port B Pressurized - CW

**Warning:** Drain line should always be used.



**SHAFT EXTENSIONS**

**C** -  $\varnothing 50$  straight, Parallel key A14x9x70 DIN 6885

**CO** -  $\varnothing 2\frac{1}{4}$ " [57,15] straight, Parallel key  $\frac{1}{2}$ " x  $\frac{1}{2}$ " x  $2\frac{1}{4}$ " BS46

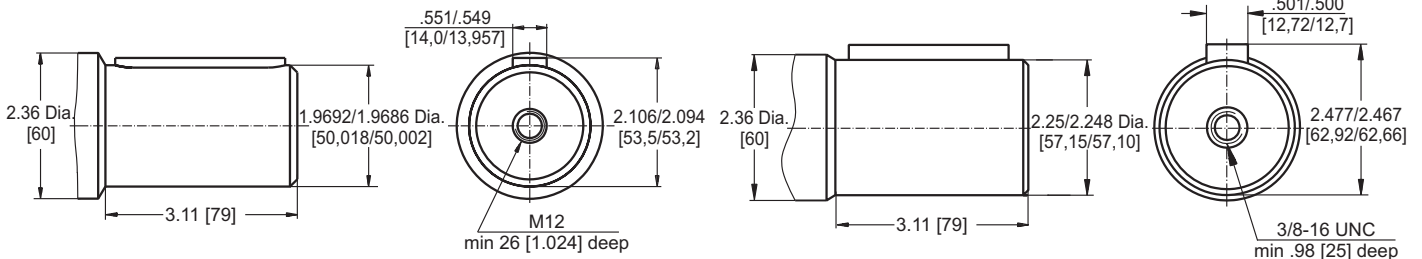

**SH** -  $\varnothing 2\frac{1}{8}$ " splined, 16 DP 8/16 ANS B92.1-1976

**K** - tapered 1:10, Parallel key B16x10x32 DIN 6885

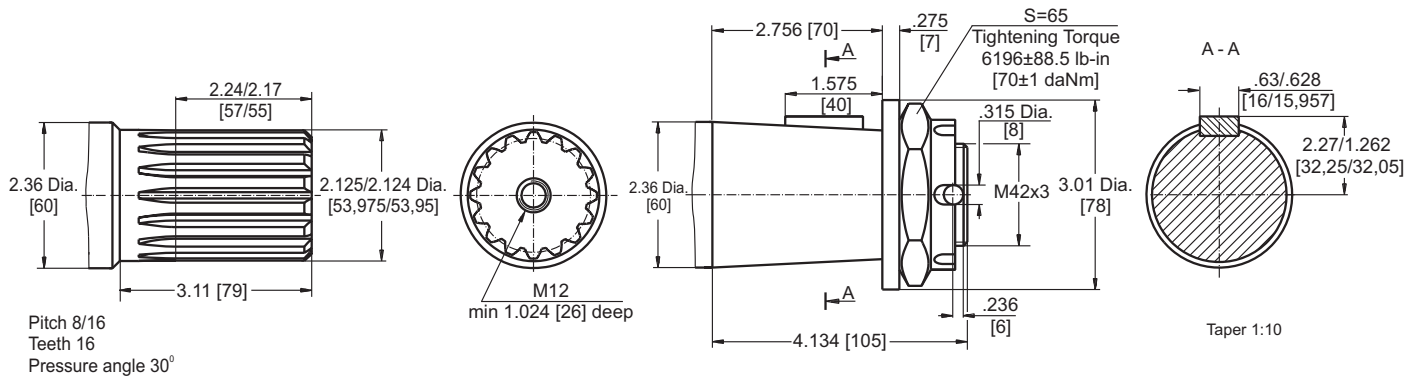

**MAX. PERMISSIBLE SHAFT SEAL PRESSURE**

**Max. return pressure without drain line or  
max. pressure in the drain line**

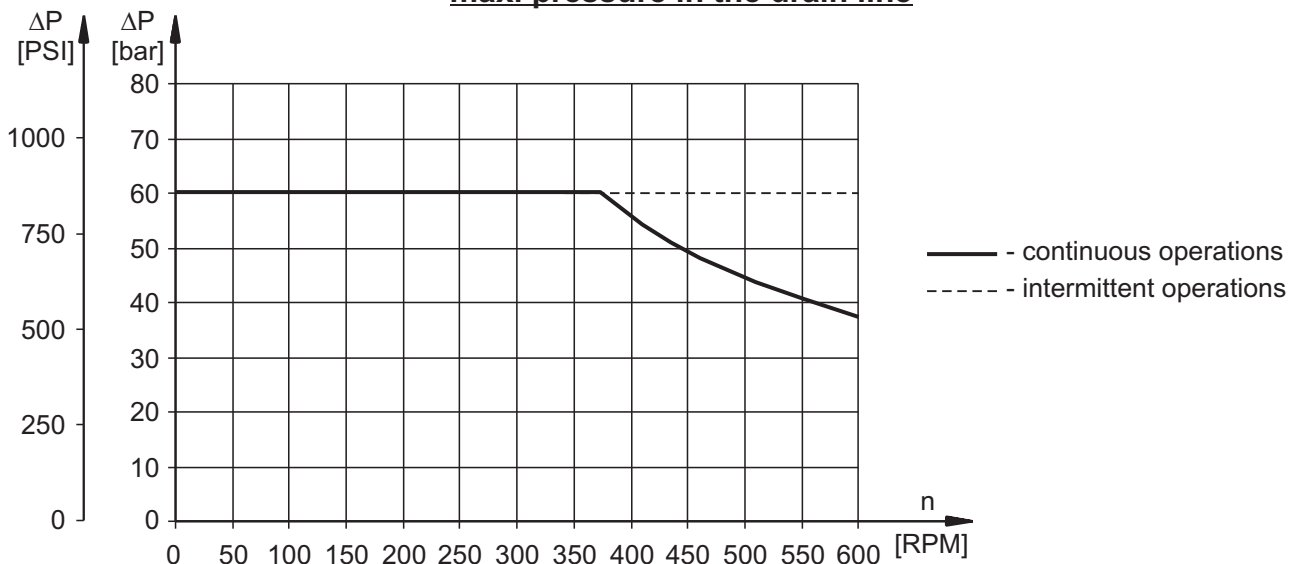

## PERMISSIBLE SHAFT LOADS

The output shaft runs in tapered bearings that permit high axial and radial forces. Curve "1" shows max. radial shaft load. Any shaft load exceeding the values quoted in the curve will seriously reduce motor life. The two other curves apply to a B10 bearing life of 3000 hours at 200 RPM.

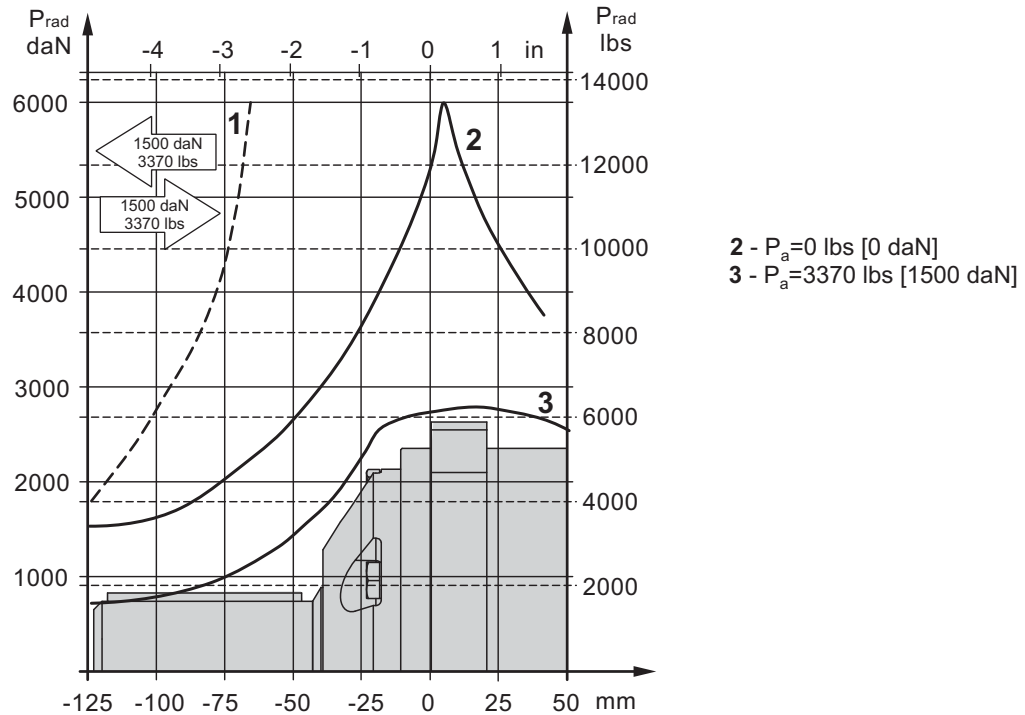

## ORDER CODE

	1	2	3	4	5	6
<b>M V M</b>						

### Pos.1 - Displacement code

<b>315</b>	- 19.18 in <sup>3</sup> /rev [314,5 cm <sup>3</sup> /rev]
<b>400</b>	- 24.45 in <sup>3</sup> /rev [400,9 cm <sup>3</sup> /rev]
<b>500</b>	- 30.48 in <sup>3</sup> /rev [499,6 cm <sup>3</sup> /rev]
<b>630</b>	- 38.38 in <sup>3</sup> /rev [629,1 cm <sup>3</sup> /rev]
<b>800</b>	- 48.91 in <sup>3</sup> /rev [801,8 cm <sup>3</sup> /rev]

### Pos.2 - Shaft Extensions\*

<b>C</b>	- $\varnothing 50$ straight, Parallel key A14x9x70 DIN6885
<b>CO</b>	- $\varnothing 2\frac{1}{4}$ " straight, Parallel key $\frac{1}{2}$ "x $\frac{1}{2}$ "x $2\frac{1}{4}$ " BS 46
<b>SH</b>	- $\varnothing 2\frac{1}{8}$ " splined, ANSI B92.1-1976
<b>K</b>	- $\varnothing 60$ tapered 1:10, Parallel key B16x10x32 DIN6885

### Pos.3 - Ports

<b>2</b>	- side ports, 2xG1, G1/4, BSP thread, ISO 228
<b>4</b>	- side ports, 2x1 5/16-12 UN, O-ring, 9/16-18 UNF

### Pos.4 - Check Valves

omit	- without check valves
<b>1</b>	- with check valves

### Pos.5 - Special Features [see page 48]

### Pos.6 - Design Series

omit	- Factory specified
------	---------------------

### NOTES:

\* The permissible output torque for shafts must be not exceeded!

The hydraulic motors are mangano-phosphatized as standard.

# HYDRAULIC MOTORS MVMC

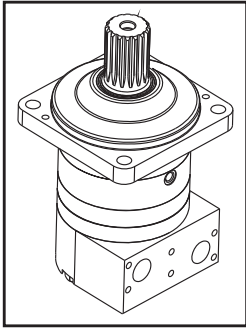

## OPTIONS

- » Model- Disc valve, roll-gerotor
- » Flange mount with wheel mount
- » Side ports
- » Shafts- straight, splined and tapered
- » Metric, SAE and BSPP ports
- » Other special features

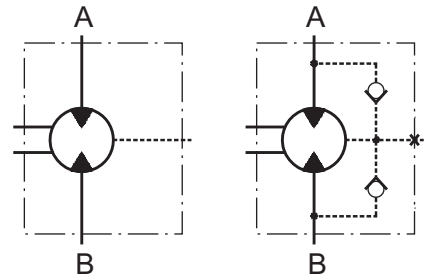

## CONTENTS

Specification data .....	40
Dimensions and mounting .....	41
Shaft extensions .....	42
Permissible shaft Seal Pressure ....	42
Permissible shaft loads .....	43
Order code .....	43

## EXCELLENCE

- » High torque and pressure drop
- » High inlet pressure
- » High starting torque
- » Improved efficiency at high pressure drop and frequent reversing
- » Smooth operation at low speed
- » High radial and axial bearing capacity

## GENERAL

<b>Max. Displacement,</b> in <sup>3</sup> /rev [cm <sup>3</sup> /rev]	48.91 [801,8]
<b>Max. Speed,</b> [RPM]	763
<b>Max. Torque,</b> lb-in [daNm]	cont.: 22920 [259] int.: 30090 [340]
<b>Max. Output,</b> HP [kW]	150 [112]
<b>Max. Pressure Drop,</b> PSI [bar]	cont.: 3630 [250] int.: 5080 [350]
<b>Max. Oil Flow,</b> GPM [lpm]	63.4 [240]
<b>Min. Speed,</b> [RPM]	5
<b>Permissible Shaft Loads,</b> lbs [daN]	Pa=3370 [1500]
<b>Pressure fluid</b>	Mineral based- HLP(DIN 51524) or HM(ISO 6743/4)
<b>Temperature range,</b> °F [°C]	-40÷284 [-40÷140]
<b>Optimal Viscosity range,</b> SUS [mm <sup>2</sup> /s]	98÷347 [20÷75]
<b>Filtration</b>	ISO code 20/16 (Min. recommended fluid filtration of 25 micron)

### Oil flow in drain line

Pressure drop PSI [bar]	Viscosity SUS [mm <sup>2</sup> /s]	Oil flow in drain line GPM [lpm]
2900 [200]	98 [20]	.660 [2,5]
	164 [35]	.400 [1,5]
3990 [275]	98 [20]	1.057 [4]
	164 [35]	.660 [2,5]

### Pressure Losses

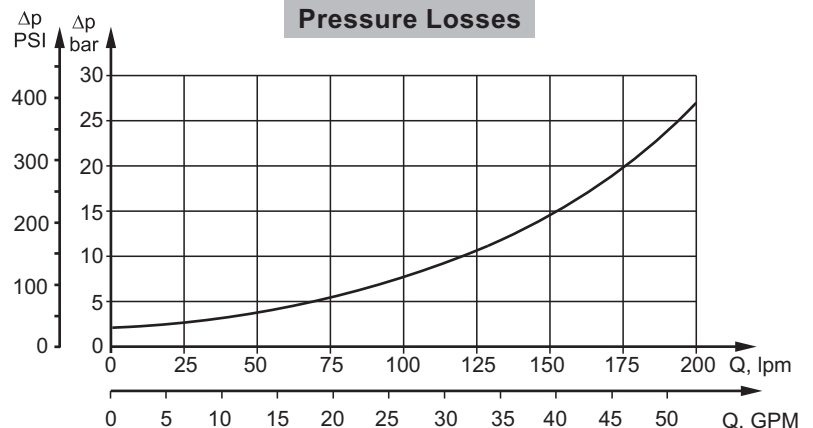

## SPECIFICATION DATA

Type		MVMC 315	MVMC 400	MVMC 500	MVMC 630	MVMC 800
<b>Displacement, in<sup>3</sup>/rev [cm<sup>3</sup>/rev]</b>		19.18 [314,5]	24.5 [400,9]	30.5 [499,6]	38.38 [629,1]	48.91 [801,8]
<b>Max. Speed, [RPM]</b>	cont.	636	500	400	315	250
	Int.*	736	600	480	380	300
<b>Max. Torque lb-in [daNm]</b>	cont.	10180 [115]	12745 [144]	15930 [180]	20090 [227]	22920 [259]
	Int.*	14160 [160]	17700 [200]	23010 [260]	27440 [310]	30090 [340]
	peak**	15930 [180]	20355 [230]	25315 [286]	31860 [360]	35580 [402]
	start	8143 [92]	10180 [115]	12745 [144]	15930 [180]	18144 [205]
<b>Max. Output HP [kW]</b>	cont.	90 [67]	90 [67]	90 [67]	90 [67]	90 [67]
	int.*	150 [112]	150 [112]	150 [112]	150 [112]	150 [112]
<b>Max. Pressure Drop PSI [bar]</b>	cont.	3630 [250]	3630 [250]	3630 [250]	3630 [250]	3630 [250]
	Int.*	[5080 [350]	[5080 [350]	[5080 [350]	[5080 [350]	[5080 [350]
	peak**	5800 [400]	5800 [400]	5800 [400]	5800 [400]	5800 [400]
<b>Max. Oil Flow GPM [lpm]</b>	cont.	52.8 [200]	52.8 [200]	52.8 [200]	52.8 [200]	52.8 [200]
	Int.*	63.4 [240]	63.4 [240]	63.4 [240]	63.4 [240]	63.4 [240]
<b>Max. Starting Pressure with Unloaded Shaft, PSI [bar]</b>		70 [5]	70 [5]	70 [5]	70 [5]	70 [5]
<b>Drain Pressure, PSI [bar]</b>		P <sub>atm.</sub>				
<b>Weight, lb [kg]</b>		96.6 [43,8]	99 [44,9]	101 [45,8]	106.5 [48,3]	111.1 [50,4]

\* Intermittent operation: the permissible values may occur for max. 10% of every minute.

\*\* Peak load: the permissible values may occur for max. 1% of every minute.

\*\*\* For speeds of 5 RPM lower than given, consult factory or your regional manager.

1. Intermittent speed and intermittent pressure must not occur simultaneously.
2. Recommended filtration is per ISO cleanliness code 20/16. A nominal filtration of 25 micron or better.
3. Recommend using a premium quality, anti-wear type mineral based hydraulic oil, HLP(DIN51524) or HM(ISO6743/4).  
If using synthetic fluids consult the factory for alternative seal materials.
4. Recommended minimum oil viscosity 70 SUS [13 cmi/s] at 122°F [50°C].
5. Recommended maximum system operating temperature is 180°F [82°C].
6. To assure optimum motor life fill with fluid prior to loading and run at moderate load and speed for 10-15 minutes.



## DIMENSIONS AND MOUNTING DATA

Type	L, in [mm]	L <sub>2</sub> , in [mm]	L <sub>1</sub> , in [mm]
MVMC 315	8.957 [227,5]	6.850 [174,0]	1.00 [25,5]
MVMC 400	9.232 [234,5]	7.126 [181,0]	1.28 [32,5]
MVMC 500	9.547 [242,5]	7.441 [189,0]	1.59 [40,5]
MVMC 630	9.961 [253,0]	7.854 [199,5]	2.01 [51,0]
MVMC 800	10.518 [267,0]	8.405 [213,5]	2.56 [65,0]

Versions	
	3
<b>P(A,B)</b>	2xG1
<b>T</b>	G <sup>1</sup> / <sub>4</sub>
<b>C</b>	6xM10

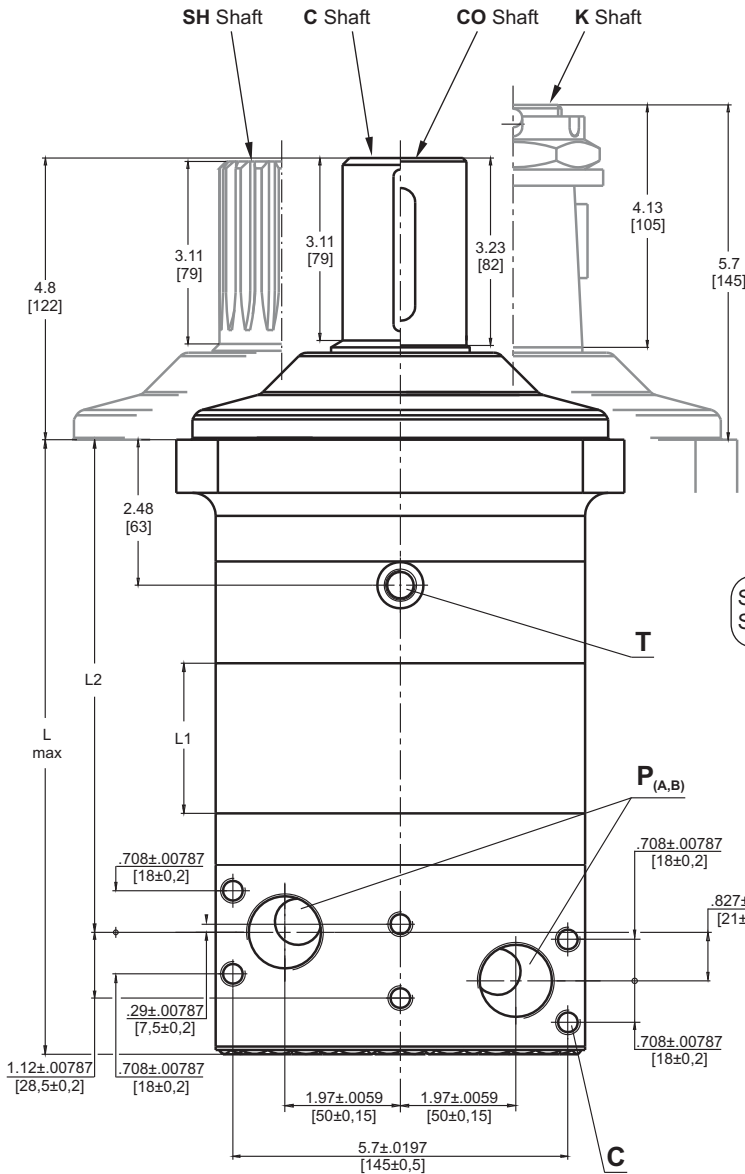
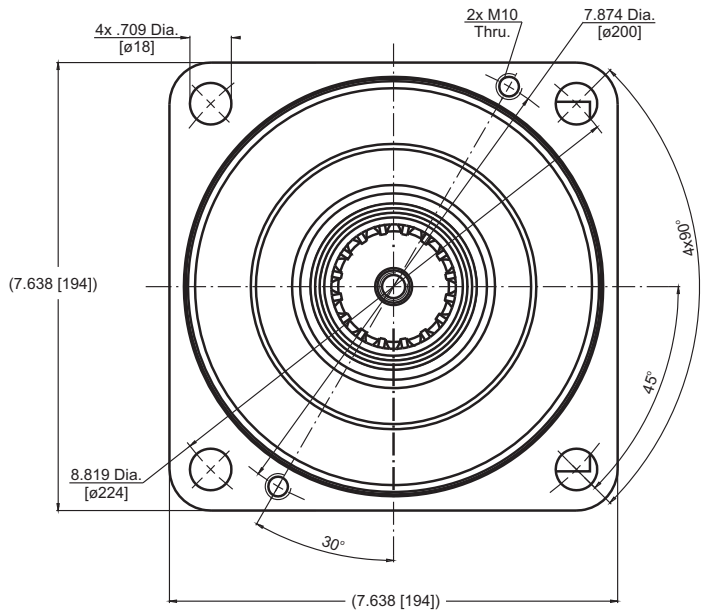

Shaft Dim.  
See Page 42

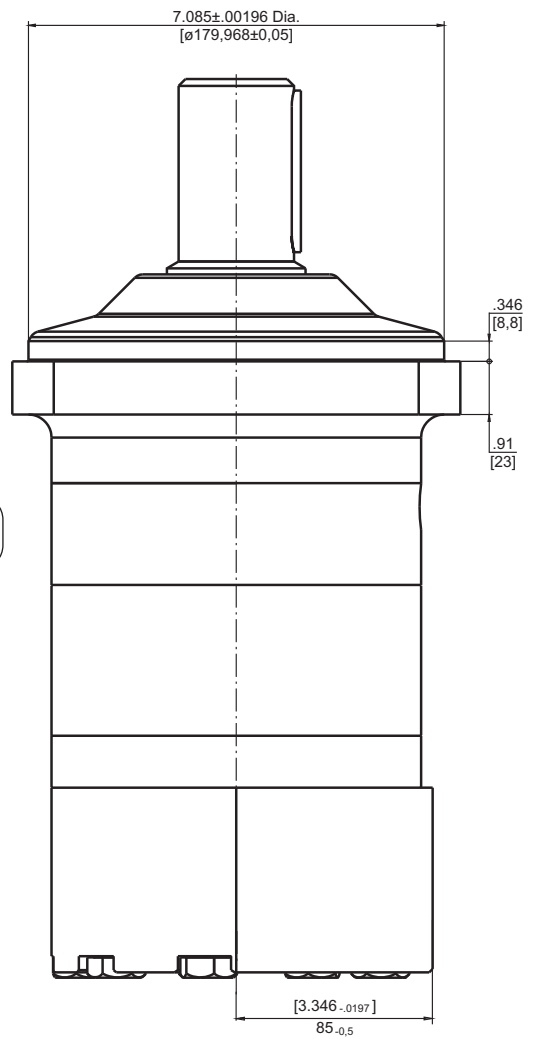

**Standard Rotation**  
Viewed from Shaft End  
Port A Pressurized - CW  
Port B Pressurized - CCW

**Reverse Rotation**  
Viewed from Shaft End  
Port A Pressurized - CCW  
Port B Pressurized - CW

**SHAFT EXTENSIONS**

**C** -  $\varnothing 50$  straight, Parallel key A14x9x70 DIN 6885

**CO** -  $\varnothing 2\frac{1}{4}$ " [57,15] straight, Parallel key  $\frac{1}{2}$ " x  $\frac{1}{2}$ " x  $2\frac{1}{4}$ " BS46

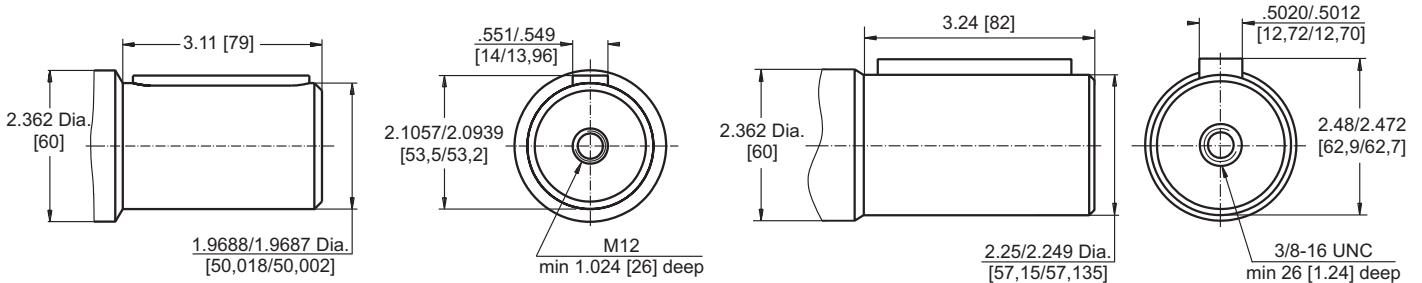

**SH** -  $\varnothing 2\frac{1}{8}$ " splined, 16 DP 8/16 ANS B92.1-1976

**K** - tapered 1:10, Parallel key B16x10x32 DIN 6885

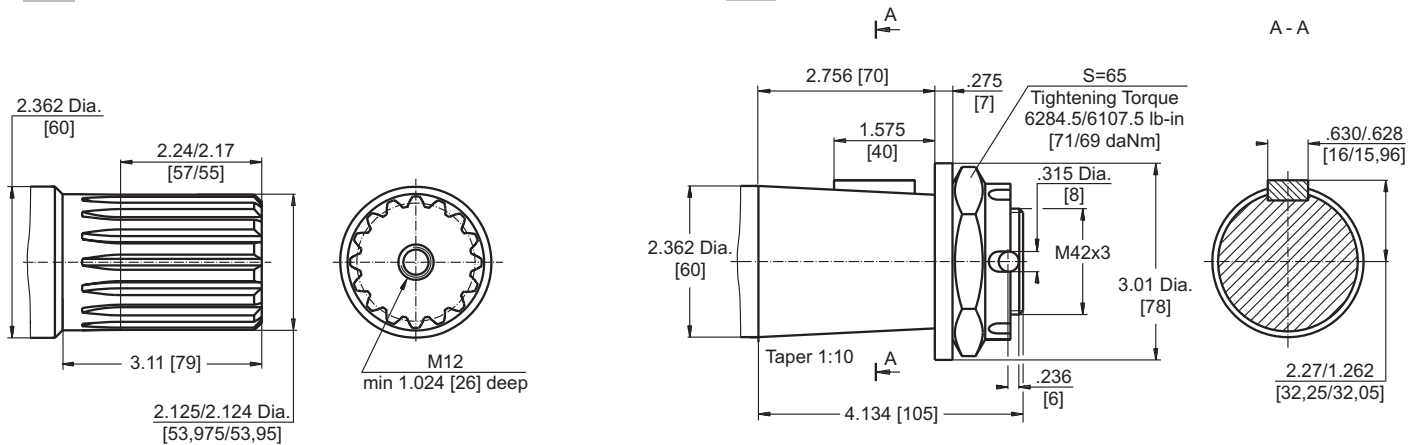

**MAX. PERMISSIBLE SHAFT SEAL PRESSURE**

**Max. return pressure without drain line or  
max. pressure in the drain line**

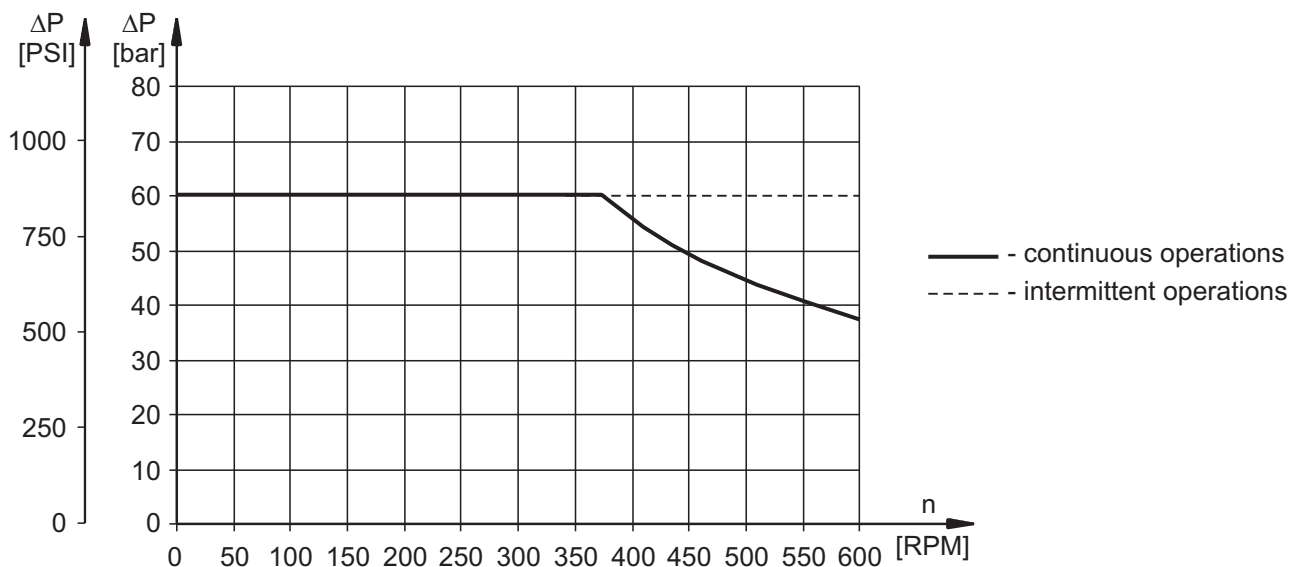

## PERMISSIBLE SHAFT LOADS

The output shaft runs in tapered bearings that permit high axial and radial forces. Curve "1" shows max. radial shaft load. Any shaft load exceeding the values quoted in the curve will seriously reduce motor life. The two other curves apply to a B10 bearing life of 3000 hours at 200 RPM.

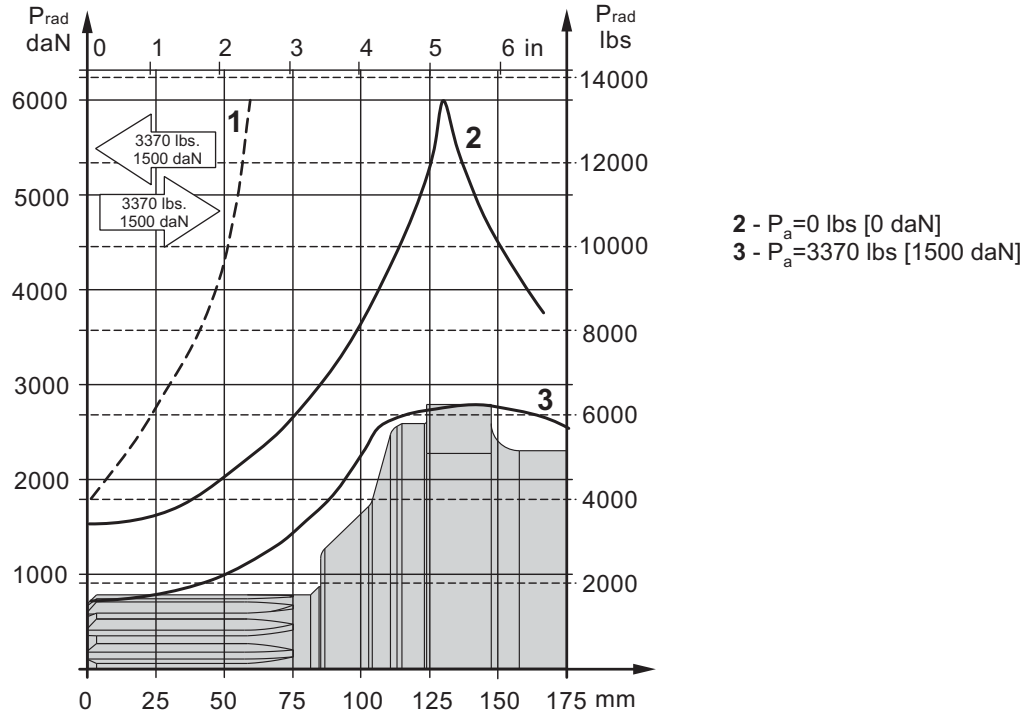

### ORDER CODE

	1	2	3	4	5	6
<b>M V M C</b>						

**Pos.1 - Displacement code**

- 315** - 19.80 in<sup>3</sup>/rev [314,5 cm<sup>3</sup>/rev]
- 400** - 24.45 in<sup>3</sup>/rev [400,9 cm<sup>3</sup>/rev]
- 500** - 30.48 in<sup>3</sup>/rev [499,6 cm<sup>3</sup>/rev]
- 630** - 38.38 in<sup>3</sup>/rev [629,1 cm<sup>3</sup>/rev]
- 800** - 48.91 in<sup>3</sup>/rev [801,8 cm<sup>3</sup>/rev]

**Pos.2 - Shaft Extensions\***

- C** - ø50 straight, Parallel key A14x9x70 DIN6885
- CO** - ø2<sup>1</sup>/<sub>4</sub>" straight, Parallel key 1<sup>1</sup>/<sub>2</sub>"x1<sup>1</sup>/<sub>2</sub>"x2<sup>1</sup>/<sub>4</sub>" BS46
- SH** - ø2<sup>1</sup>/<sub>8</sub>" splined, ANSI B92.1-1976
- K** - ø60 tapered 1:10, Parallel key B16x10x32 DIN6885

**Pos.3 - Ports**

- 3** - side ports 2xG1, G1/4, BSP thread, ISO 228, 6xM10

**Pos.4 - Check Valves**

- omit - without check valves
- 1** - with check valves

**Pos.5 - Special Features [see page 48]**

**Pos.6 - Design Series**

- omit - Factory specified

**NOTES:**

\* The permissible output torque for shafts must be not exceeded!

The hydraulic motors are mangano-phosphatized as standard.

# HYDRAULIC MOTORS VMF



## APPLICATION

- » Marine equipment
- » Forestry equipment
- » Metal working machines
- » Agriculture machines
- » Road building machines
- » Mining machinery
- » Special vehicles etc.

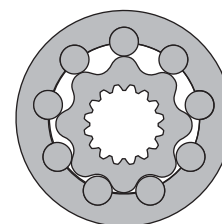
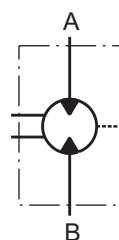

## CONTENTS

Specification data .....	45
Dimensions and mounting .....	46
Permissible shaft seal pressure .....	46
Permissible shaft loads .....	47
Order code .....	47

## OPTIONS

- » Model- Disc valve, roll-gerotor
- » Wheel mounting flange
- » Side ports
- » Shaft- thread hole flange
- » SAE and BSPP ports
- » Other special features

## GENERAL

<b>Max. Displacement,</b> in <sup>3</sup> /rev [cm <sup>3</sup> /rev]	48.91 [801,8]
<b>Max. Speed,</b> [RPM]	736
<b>Max. Torque,</b> lb-in [daNm]	cont.: 22920 [259] int.: 30090 [340]
<b>Max. Output,</b> HP [kW]	150 [112]
<b>Max. Pressure Drop,</b> PSI [bar]	cont.: 3630 [250] int.: 5080 [350]
<b>Max. Oil Flow,</b> GPM [lpm]	63.4 [240]
<b>Min. Speed,</b> [RPM]	5
<b>Permissible Shaft Loads,</b> lbs [daN]	Pa=3370 [1500]
<b>Pressure fluid</b>	Mineral based- HLP(DIN 51524) or HM(ISO 6743/4)
<b>Temperature range,</b> °F [°C]	-40÷284 [-40÷140]
<b>Optimal Viscosity range, SUS [mm<sup>2</sup>/s]</b>	98÷347 [20÷75]
<b>Filtration</b>	ISO code 20/16 (Min. recommended fluid filtration of 25 micron)

### Oil flow in drain line

Pressure drop PSI [bar]	Viscosity SUS [mm <sup>2</sup> /s]	Oil flow in drain line GPM [lpm]
2900 [200]	98 [20]	.660 [2,5]
	164 [35]	.400 [1,5]
275 [3990]	98 [20]	1.057 [4]
	164 [35]	.660 [2,5]

### Pressure Losses

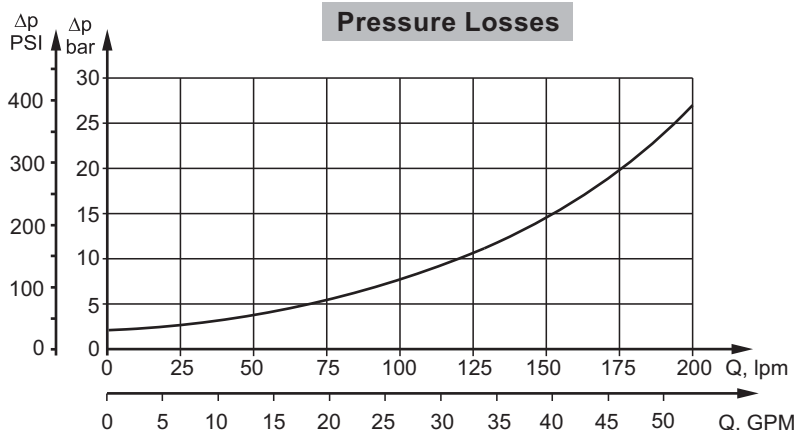

## SPECIFICATION DATA

Type		VMF 315	VMF 400	VMF 500	VMF 630	VMF 800
<b>Displacement, in<sup>3</sup>/rev [cm<sup>3</sup>/rev]</b>		19.18 [314,5]	24.5 [400,9]	30.5 [499,6]	38.38 [629,1]	48.91 [801,8]
<b>Max. Speed, [RPM]</b>	cont.	636	500	400	315	250
	Int.*	736	600	480	380	300
<b>Max. Torque lb-in [daNm]</b>	cont.	10180 [115]	12745 [144]	15930 [180]	20090 [227]	22920 [259]
	Int.*	14160 [160]	17700 [200]	23010 [260]	27440 [310]	30090 [340]
	peak**	15930 [180]	20355 [230]	25315 [286]	31860 [360]	35580 [402]
<b>Max. Output HP [kW]</b>	cont.	90 [67]	90 [67]	90 [67]	90 [67]	90 [67]
	int.*	150 [112]	150 [112]	150 [112]	150 [112]	150 [112]
<b>Max. Pressure Drop PSI [bar]</b>	cont.	3630 [250]	3630 [250]	3630 [250]	3630 [250]	3263 [225]
	Int.*	5080 [350]	5080 [350]	5080 [350]	5080 [350]	4350 [300]
	peak**	5800 [400]	5800 [400]	5800 [400]	5800 [400]	5080 [350]
<b>Max. Oil Flow GPM [lpm]</b>	cont.	52.8 [200]	52.8 [200]	52.8 [200]	52.8 [200]	52.8 [200]
	Int.*	63.4 [240]	63.4 [240]	63.4 [240]	63.4 [240]	63.4 [240]
<b>Max. Inlet Pressure PSI [bar]</b>	cont.	3915 [270]	3915 [270]	3915 [270]	3915 [270]	3915 [270]
	Int.*	5365 [370]	5365 [370]	5365 [370]	5365 [370]	5365 [370]
	peak**	6090 [420]	6090 [420]	6090 [420]	6090 [420]	6090 [420]
<b>Max. Return Pressure with Drain Line PSI [bar]</b>	cont.	2030 [140]	2030 [140]	2030 [140]	2030 [140]	2030 [140]
	Int.*	2540 [175]	2540 [175]	2540 [175]	2540 [175]	2540 [175]
	peak**	3045 [210]	3045 [210]	3045 [210]	3045 [210]	3045 [210]
<b>Max. Starting Pressure with Unloaded Shaft, PSI [bar]</b>		70 [5]	70 [5]	70 [5]	70 [5]	70 [5]
<b>Min. Starting Torque lb-in [daNm]</b>		8140 [92]	10180 [115]	12745 [144]	15930 [180]	18145 [205]
<b>Min. Speed***, [RPM]</b>		10	6	8	6	5
<b>Weight, lb [kg]</b>		101.4 [46]	104.1 [47,2]	106.9 [48,5]	110.2 [50]	113.5 [51,5]

\* Intermittent operation: the permissible values may occur for max. 10% of every minute.

\*\* Peak load: the permissible values may occur for max. 1% of every minute.

\*\*\* For speeds lower than given, consult factory or your regional manager.

1. Intermittent speed and intermittent pressure drop must not occur simultaneously.
2. Recommended filtration is per ISO cleanliness code 20/16. A nominal filtration of 25 micron or better.
3. Recommend using a premium quality, anti-wear type mineral based hydraulic oil HLP(DIN51524) or HM (ISO 6743/4).  
If using synthetic fluids consult the factory for alternative seal materials.
4. Recommended minimum oil viscosity 70 SUS [13 mm<sup>2</sup>/s] at 122°F [50°C].
5. Recommended maximum system operating temperature is 180°F [82°C].
6. To assure optimum motor life fill with fluid prior to loading and run at moderate load and speed for 10-15 minutes.

**DIMENSIONS AND MOUNTING DATA**

	Versions	
	2	4
<b>P(A,B)</b>	2xG1	2x1 <sup>5</sup> / <sub>16</sub> -12UN
<b>T</b>	G <sup>1</sup> / <sub>4</sub>	9 <sup>16</sup> -18UNF

Type	L, in [mm]	L <sub>1</sub> , in [mm]	L <sub>2</sub> , in [mm]
<b>VMF 315</b>	11.28 [286,5]	1.00 [25,5]	4.31 [109,5]
<b>VMF 400</b>	11.56 [293,5]	1.28 [32,5]	4.59 [116,5]
<b>VMF 500</b>	11.87 [301,5]	1.59 [40,5]	4.90 [124,5]
<b>VMF 630</b>	12.28 [312,0]	2.01 [51,0]	5.31 [135,0]
<b>VMF 800</b>	12.83 [326,0]	2.56 [65,0]	5.87 [149,0]

**Standard Rotation**  
Viewed from Shaft End  
Port A Pressurized - **CW**  
Port B Pressurized - **CCW**

**Reverse Rotation**  
Viewed from Shaft End  
Port A Pressurized - **CCW**  
Port B Pressurized - **CW**

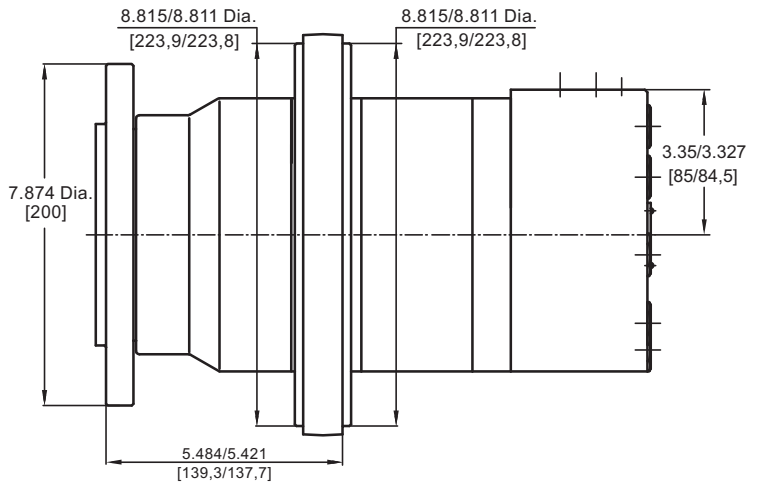
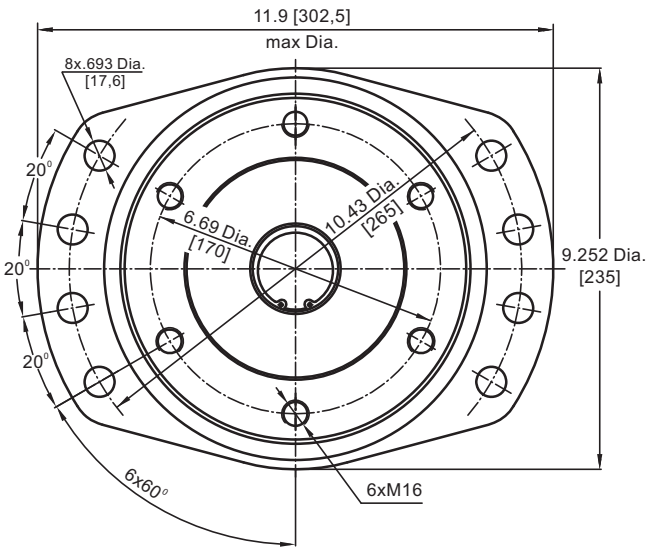
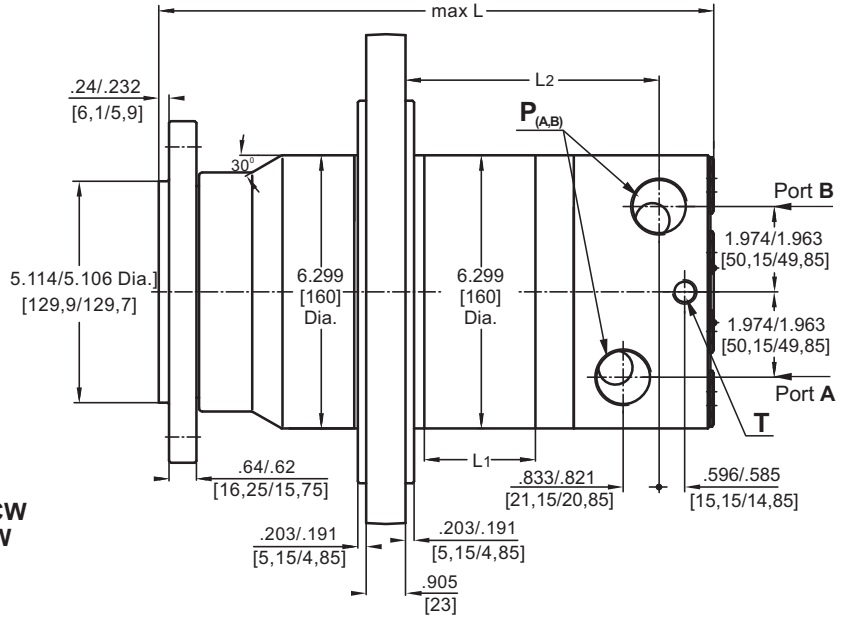

**Warning:** Drain line should always be used.

**MAX. PERMISSIBLE SHAFT SEAL PRESSURE**

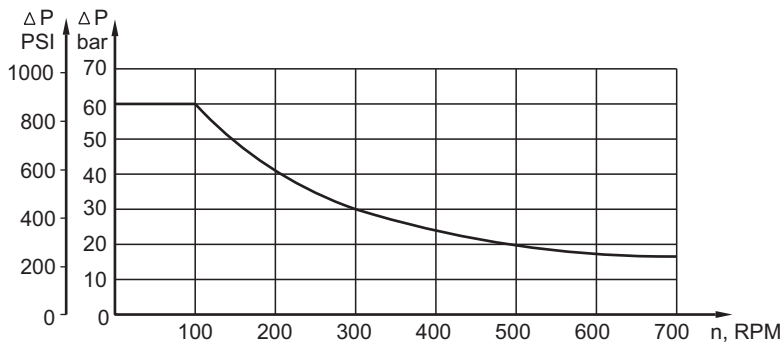

**PERMISSIBLE SHAFT LOADS**

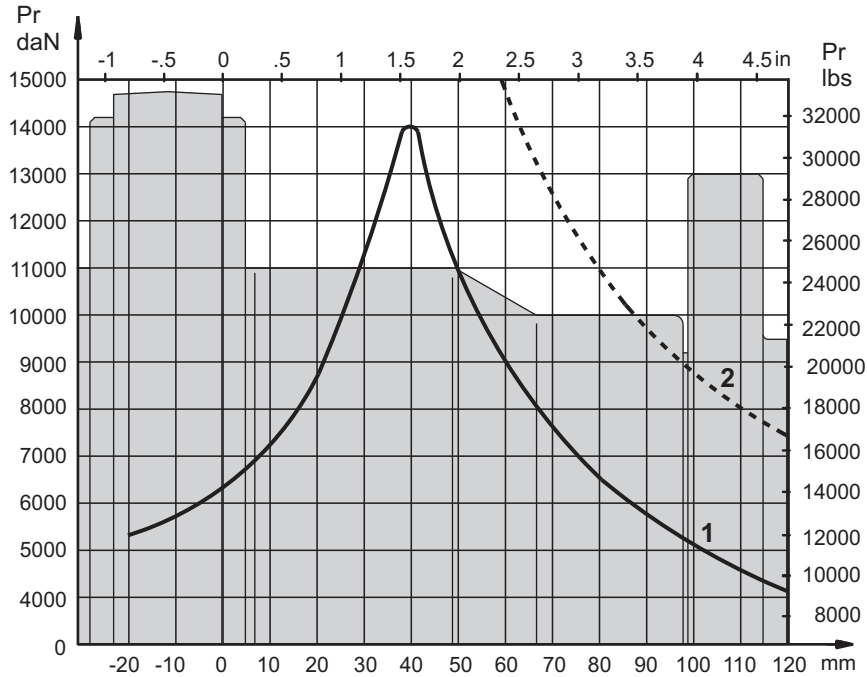

- 1 - Bearing curve: The curve applies to a B10 bearing life of 2000 hours at 100 RPM.
- 2 - Shaft curve: The curve represents Max. permissible radial shaft load with safety factor 2:1.

**ORDER CODE**

	1	2	3	4
<b>VMF</b>				

**Pos.1 - Displacement code**

- 315** - 19.18 in<sup>3</sup>/rev [314,5 cm<sup>3</sup>/rev]
- 400** - 24.45 in<sup>3</sup>/rev [400,9 cm<sup>3</sup>/rev]
- 500** - 30.48 in<sup>3</sup>/rev [499,6 cm<sup>3</sup>/rev]
- 630** - 38.38 in<sup>3</sup>/rev [629,1 cm<sup>3</sup>/rev]
- 800** - 48.91 in<sup>3</sup>/rev [801,8 cm<sup>3</sup>/rev]

**Pos.2 - Ports**

- 2** - side ports, 2xG1, G<sup>1</sup>/<sub>4</sub>, BSP thread, ISO 228
- 4** - side ports, 2x1<sup>5</sup>/<sub>16</sub>-12 UN, O-ring, <sup>9</sup>/<sub>16</sub>-18 UNF

**Pos.3 - Special Features** [see page 48]

**Pos.4 - Design Series**

- omit - Factory specified

The hydraulic motors are mangano-phosphatized as standard.

# MOTOR SPECIAL FEATURES

Special Feature Description	Order Code	Motor type						
		MLHSEM	MTK	MLHTM	TMF	MVM	MVMC	VMF
Speed Sensor*	RS	O	O	O	O	O	-	O
Reinforced motor	HD	-	-	O	O	O	-	O
Low Leakage	LL	O	O	O	O	O	O	O
Low Speed Valving	LSV	O	O	O	O	O	O	O
Free Running	FR	-	O	-	-	-	O	-
Reverse Rotation	R	O	O	O	O	O	O	O
Paint**	P	O	O	O	O	O	O	O
Corrosion Protected Paint**	PC	O	O	O	O	O	O	O
Check Valves		S	O	O	-	O	O	-

- O** Optional
- Not applicable
- S** Standard

\* For sensor ordering see pages 49-50.

\*\* Color at customer's request.

 For more information about **HD** option please contact with "M+S Hydraulic".



# MOTORS WITH SPEED SENSOR

## MLHSEM...RS

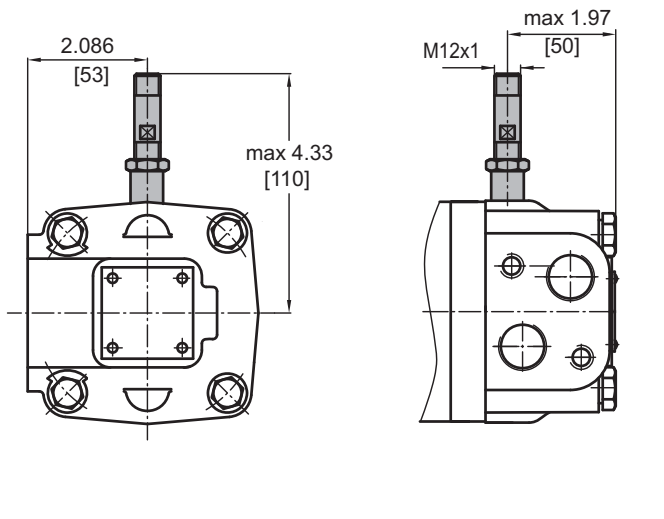

## MTK...RS

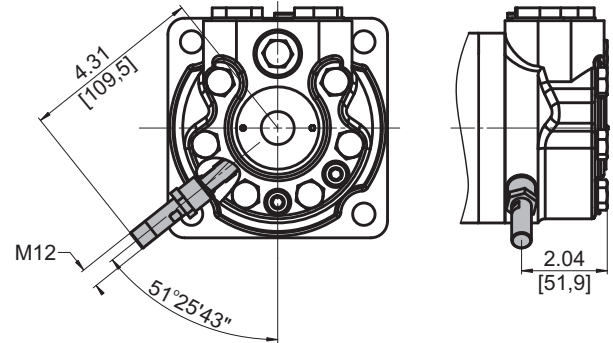

## MLHTM...RS TMF...RS

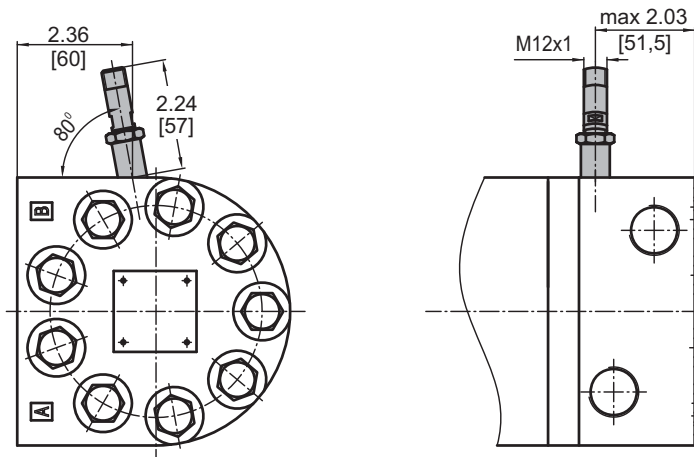

## MVM...RS VMF...RS

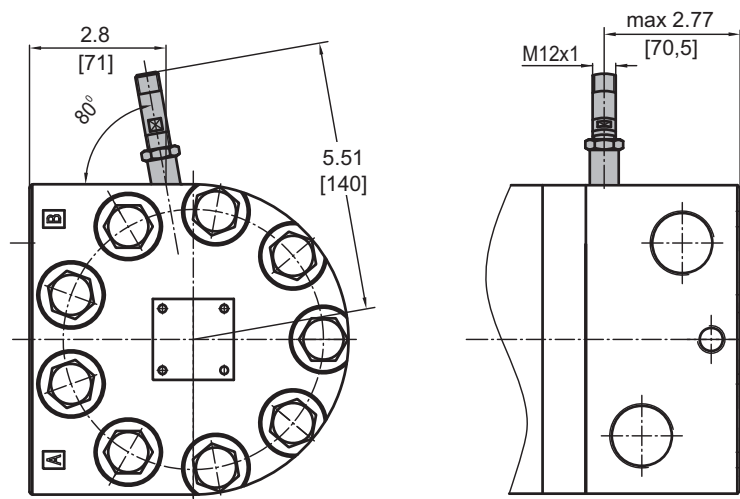

**TECHNICAL DATA OF THE SPEED SENSOR**

**Technical data**

Frequency range	0...15 000 Hz
Output	PNP, NPN
Power supply	10...36 VDC
Current input	20 mA (@24 VDC)
Ambient Temperature	-40...+125°C [-40...+257°F]
Protection	IP 67
Plug connector	M12-Series
Mounting principle	ISO 6149

**Output signal**

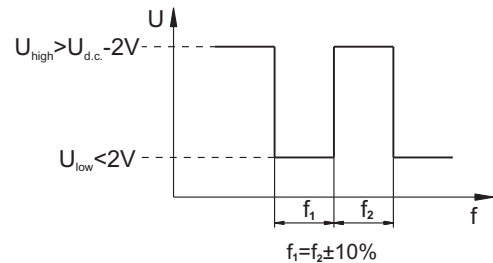

Load max.:  $I_{high} = I_{low} < 50 \text{ mA}$

Motor type	MLHSEM MTK	MLHTM TMF	MVM VMF
Pulses per revolution	54	84	102

**Wiring diagrams**

**PNP**

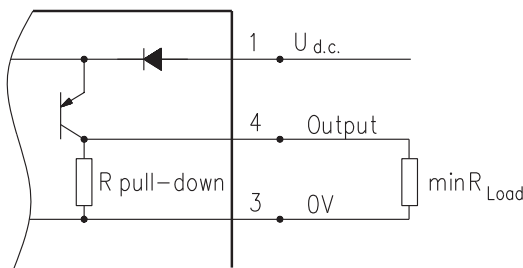

**NPN**

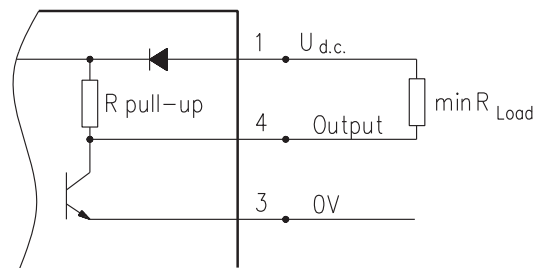

$$R_{Load} [\text{k}\Omega] = U_{d.c.} [\text{V}] / I_{max} [\text{mA}]$$

**Stick type**

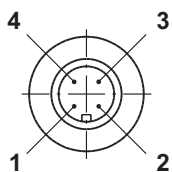

Terminal No.	Connection	Cable Output
1	$U_{d.c.}$	Brown
2	No connection	White
3	0V	Blue
4	Output signal	Black

**Order Code for Speed Sensor**

Sensor Code	Output type	Electric connection
RSN	NPN	Connector BINDER 713 series
RSP	PNP	Connector BINDER 713 series
RSNL5	NPN	Cable output 3x0,25; 196 in [5 m] long
RSPL5	PNP	Cable output 3x0,25; 196 in [5 m] long

**NOTE:** \*- The speed sensor is not fitted at the factory, but is supplied in a plastic bag with the motor. For installation see enclosed instructions.

# APPLICATION CALCULATION

## VEHICLE DRIVE CALCULATIONS

### 1. Motor speed: n, RPM

$$n = \frac{168 \times v_{mi} \times i}{R_m} \quad n = \frac{2,65 \times v_{km} \times i}{R_m}$$

$v_{km}$ - vehicle speed, km/h;

$v_{mi}$ - vehicle speed, mile/h;

$R_m$ - wheel rolling radius, m;

$R_{in}$ - wheel rolling radius, in;

$i$ - gear ratio between motor and wheels.

If no gearbox, use  $i=1$ .

### 2. Rolling resistance: RR, lbs [daN]

The resistance force resulted in wheels contact with different surfaces:

$$RR = G \times \rho$$

$G$ - total weight loaded on vehicle, lbs [daN];

$\rho$ - rolling resistance coefficient (Table 1).

Table 1

Rolling resistance coefficient In case of rubber tire rolling on different surfaces	
Surface	$\rho$
Concrete- faultless	0.010
Concrete- good	0.015
Concrete- bad	0.020
Asphalt- faultless	0.012
Asphalt- good	0.017
Asphalt- bad	0.022
Macadam- faultless	0.015
Macadam- good	0.022
Macadam- bad	0.037
Snow- 5 cm	0.025
Snow- 10 cm	0.037
Polluted covering- smooth	0.025
Polluted covering- sandy	0.040
Mud	0.037÷0.150
Sand- Gravel	0.060÷0.150
Sand- loose	0.160÷0.300

### 3. Grade resistance: GR, lbs [daN]

$$GR = G \times (\sin \alpha + \rho \times \cos \alpha)$$

$\alpha$ - gradient negotiation angle (Table 2)

Table 2

Grade %	$\alpha$ Degrees	Grade %	$\alpha$ Degrees
1%	0° 35'	12%	6° 5'
2%	1° 9'	15%	8° 31'
5%	2° 51'	20%	11° 19'
6%	3° 26'	25%	14° 3'
8%	4° 35'	32%	18°
10%	5° 43'	60%	31°

### 4. Accelerate force: FA, lbs [daN]

Force  $FA$  necessary for acceleration from 0 to maximum speed  $v$  and time  $t$  can be calculated with a formula:

$$FA = \frac{v_{mi} \times G}{22 \times t}, [\text{lbs}]; \quad FA = \frac{v_{km} \times G}{3,6 \times t}, [\text{daN}]$$

$FA$ - accelerate force, lbs [daN];

$t$ - time, [s].

### 5. Tractive effort: DP, lbs [daN]

Tractive effort  $DP$  is the additional force of trailer. This value will be established as follows:

-acc.to constructor's assessment;

-as calculating forces in items 2, 3 and 4 of trailer; the calculated sum corresponds to the tractive effort requested.

### 6. Total tractive effort: TE, lbs [daN]

Total tractive effort  $TE$  is total effort necessary for vehicle motion; that the sum of forces calculated in items from 2 to 5 and increased with 10 % because of air resistance.

$$TE = 1,1 \times (RR + GR + FA + DP)$$

$RR$ - force acquired to overcome the rolling resistance;

$GR$ - force acquired to slope upwards;

$FA$ - force acquired to accelerate (acceleration force);

$DP$ - additional tractive effort (trailer).

### 7. Motor Torque moment: M, lb-in [daNm]

Necessary torque moment for every hydraulic motor:

$$M = \frac{TE \times R_{in} [R_m]}{N \times i \times \eta_M}$$

$N$ - motor numbers;

$\eta_M$ - mechanical gear efficiency (if it is available).

### 8. Cohesion between tire and road covering: $M_w$ , lb-in [daNm]

$$M_w = \frac{G_w \times f \times R_{in} [R_m]}{i \times \eta_M}$$

To avoid wheel slipping, it should be observed the following condition  $M_w > M$

$f$  - frictional factor;

$G_w$ - total weight over the wheels, lbs [daN].

Table 3

Surface	Frictional factor $f$
Steel on steel	0.15 ÷ 0.20
Rubber tire on polluted surface	0.5 ÷ 0.7
Rubber tire on asphalt	0.8 ÷ 1.0
Rubber tire on concrete	0.8 ÷ 1.0
Rubber tire on grass	0.4

**9.Radial motor loading:  $P_{rad}$ , lbs [daN]**

When motor is used for vehicle motion with wheels mounted directly on motor shaft, the total radial loading of motor shaft  $P_{rad}$  is a sum of motion force and weight force acting on one wheel.

- $G_w$  - Weight held by wheel;
- $P_{rad}$  - Total radial loading of motor shaft;
- $M/R$  - Motion force.

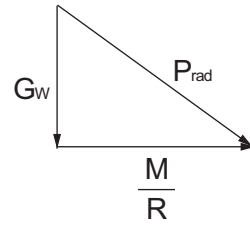

$$P_{rad} = \sqrt{G_w^2 + \left(\frac{M}{R}\right)^2}$$

In accordance with calculated loadings the suitable motor from the catalogue is selected.

**DRAINAGE SPACE AND DRAINAGE PRESSURE**

Advantages in oil drainage from drain space: Cleaning; Cooling and Seal lifetime prolonging.

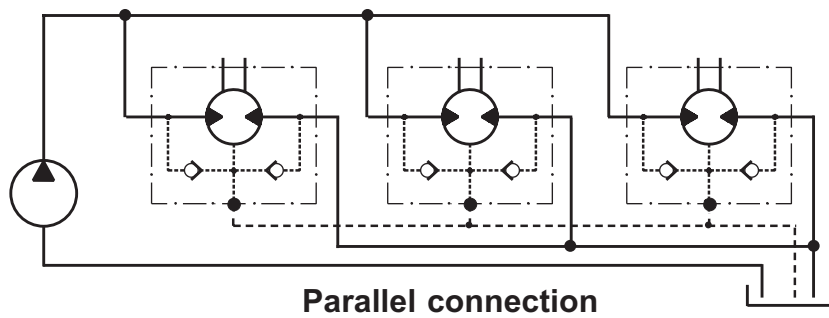
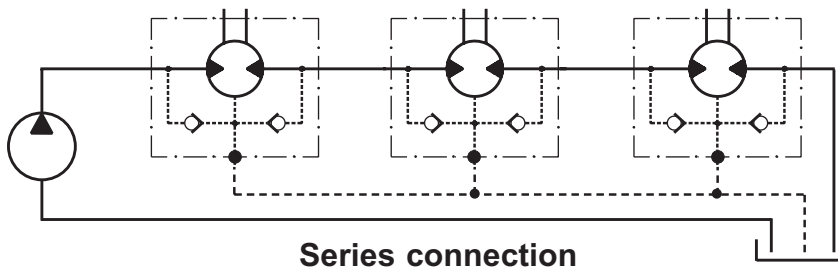

# WARRANTY

M+S Hydraulic warrants, what its products, supplied directly to original equipment manufacturer, authorized distributor or other customer, will be free of defects in material or workmanship at the time of shipment from M+S Hydraulic and will conform to the products technical documentation (drawings and specifications) under sale agreement with Buyer.

This warranty will apply only to defects appearing within applicable Warranty period, mentioned below. If Buyer notify M+S Hydraulic within the Warranty period about any such defects, M+S , at its sole option will replace or repair the defective products or their parts found by M+S Hydraulic to be defective in material or workmanship.

THE FOREGOING LIMITED WARRANTY IS AVAILABLE ONLY IF "M+S HYDRAULIC" IS PROMPTLY NOTIFIED IN WRITING OF THE ALLEGED DEFECT AND DOES NOT COVER FAILURE TO FUNCTION CAUSED BY DAMAGE TO THE PRODUCT, IMPROPER INSTALLATION, UNREASONABLE USE OR ABUSE OF THE PRODUCT, FAILURE TO PROVIDE OR USE OF IMPROPER MAINTENANCE OR USUAL, DEGRADATION OF THE PRODUCT DUE TO PHYSICAL ENVIRONMENTS OF AN USUAL NATURE. THE FOREGOING REMEDIES ARE THE SOLE AND EXCLUSIVE REMEDIES AVAILABLE TO CUSTOMER. To facilitate the inspection, M+S Hydraulic may require return of the product/part, which Buyer claims to be defective.

M+S Hydraulic shall not be liable for labor costs or any other expenses incurred during the disassembling or reinstalling of the product/part.

In case the claimed products are returned to M+S Hydraulic in bad condition: dirty, disassembled, with damaged or missing parts during transportation, the warranty will be considered as not applicable and the products will not be liable to repair.

## Warranty periods

**New products:** The Warranty period is limited to 24 consecutive months (2 years) from the date of production of the product.

**Repaired products:** If the product is repaired in M+S Hydraulic during its warranty period, the warranty period of the repaired item shall continue for the balance of original Warranty period or for a period equal to 50% of the original new product Warranty period, whichever is later.

**Spare parts:** The Warranty period for Spare parts shall be 12 consecutive months (1 year) from the dispatch date of such parts from M+S Hydraulic.

**LIMITATION OF LIABILITY** M+S Hydraulic's liability for any claim of any kind , for any loss or damage arising out of, connected with or resulting from an order, or from the performance or branch thereof, or from the design, manufacture, sale delivery, operation or use of any of its products shall be limited to , at M+S 's sole option, replacement, repair of any defective product or the issuance of a credit to Customer against any future purchases. Cash refunds will not be made under any circumstances and Customer will not be entitled to recover any damages of any kind against M+S Hydraulic, including but not limited to incidental or consequential damages, whether direct or indirect, known or unknown, foreseen or unforeseen.